

技术要求:

- 1、必须按照设计、工艺要求及本规定和有关标准进行装配;
- 2、所有零部件(包括外购、外协件)必须具有检验合格证方能进行装配;
- 3、零件在装配前必须清理和清洗干净,不得有毛刺、飞边、氧化皮、锈蚀、切屑、砂粒、灰尘和油污等,并应符合相应清洁度要求;
- 4、装配过程中零件不得磕碰、划伤和锈蚀;
- 5、油漆未干的零件不得进行装配;
- 6、相对运动的零件,装配时接触面间应加润滑油脂;
- 7、各零、部件装配后相对位置应准确。

序号	图号	名称	材料	数量	单重	备注
5	GB-T-819.1-2000-C-BE-M3X6	碳钢发黑十字沉头螺丝M3X6	普通碳钢	14	0.0004	
4	YG-G06C-0000-004	侧板	6063-T5	2	0.064	
3	YG-G06C-0000-003	底板	5052-H32	1	0.160	
2	YG-G06C-0000-002	上盖板	5052-H32	1	0.192	
1	YG-G06C-0000-001	前后面板	5052-H32	2	0.028	

Tolerances (未注公差): 0.5 to 6 ± 0.1 6 to 30 ± 0.2 30 to 120 ± 0.3 120 to 400 ± 0.4	Material (材料): (装配图)	YONGU 永固	Drawing Number (图号):		
	Weight: (重量) (Kg): 0.542		YG-G06C-0000-000		
Protection: (表面处理):					
Part Name (零/部件名称):	G06C机箱				
Break sharp edges (未注锐边倒角): Ch 0.05 to 0.25 x45°	Angular tolerances (未注角度公差): <6° ± 10' <30° ± 20' <120° ± 30' >120° ± 1°	Drawn by (绘图): 莫永康	Date (日期): 2020.05.28	Size: (图幅): A1	 Sheet (页数): 1 / 1
Position tolerances (未注位置公差): ± 0.05		Check by (校对):	Date (日期):	Scale (比例): 1:1	
		Signature by (批准):	Date (日期):	Revision (版本): A1	

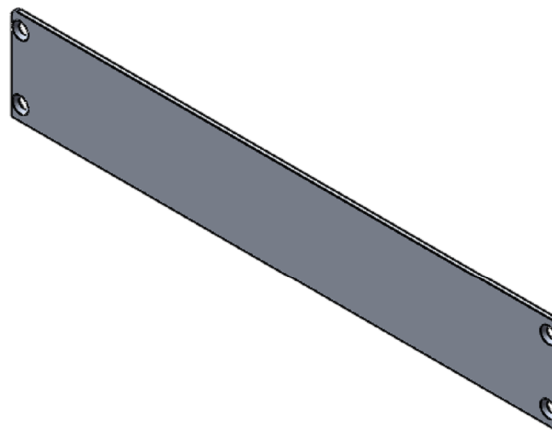
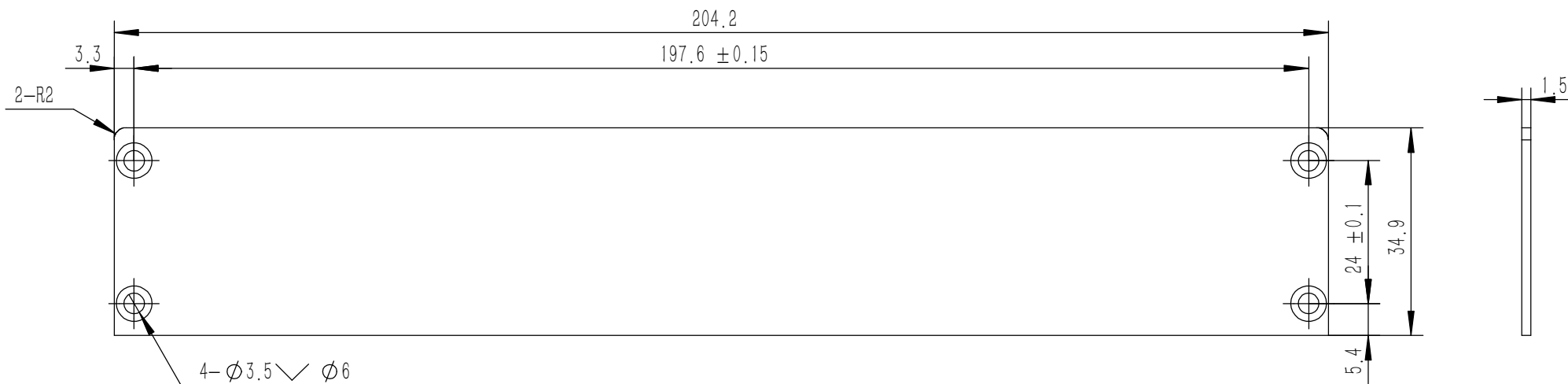

技术要求:

- 1、零件加工表面不应有划痕、擦伤等损伤零件表面的缺陷;
- 2、去除毛刺飞边, 锐角倒钝;
- 3、未标注尺寸见3D数模。

Tolerances (未注公差): 0.5 to 6 ± 0.1 6 to 30 ± 0.2 30 to 120 ± 0.3 120 to 400 ± 0.4	Material (材料): 5052-H32	YONGU 永固	
	Weight: (重量) (Kg) 0.028		
Break sharp edges (未注锐边倒角): Ch 0.05 to 0.25 x45°	Protection: (表面处理):	Part Name (零/部件名称): 前后面板	
	Position tolerances (未注位置公差): ±0.05	Angular tolerances (未注角度公差): <6° ± 10' <30° ± 20' <120° ± 30' >120° ± 1°	Drawing Number (图号): YG-G06C-0000-001
	Drawn by (绘图): 莫永康	Date (日期): 2020.05.28	Size: (图幅): A4
	Check by (校对):	Date (日期):	Scale (比例): 1:1
	Signature by (批准):	Date (日期):	Revision (版本): A1
			Sheet (页数): 1 / 1

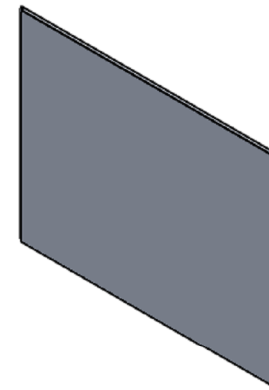
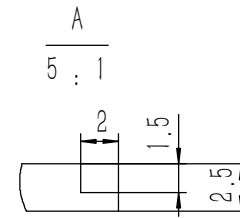
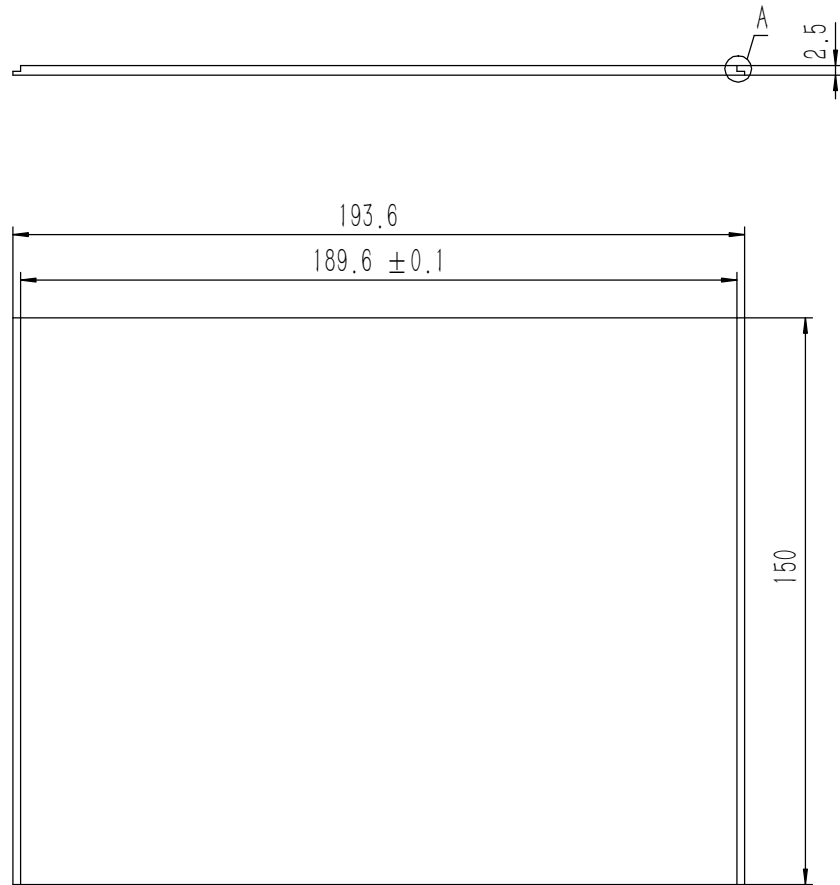

- 技术要求:
- 1、零件加工表面不应有划痕、擦伤等损伤零件表面的缺陷;
 - 2、去除毛刺飞边,锐角倒钝;
 - 3、未标注尺寸见3D数模。

Tolerances (未注公差):	Material (材料):	5052-H32	
	0.5 to 6 ± 0.1	Weight: (重量) (Kg):	0.192
6 to 30 ± 0.2	Protection: (表面处理):		
30 to 120 ± 0.3	Part Name (零/部件名称):	上盖板	
120 to 400 ± 0.4	Drawing Number (图号):	YG-G06C-0000-002	
Break sharp edges (未注锐边倒角): Ch 0.05 to 0.25 x45°	Angular tolerances (未注角度公差):	Drawn by (绘图):	Date (日期): 2020.05.28
Position tolerances (未注位置公差): ±0.05	<6° ± 10' <30° ± 20' <120° ± 30' >120° ± 1°	Check by (校对):	Date (日期):
		Signature by (批准):	Date (日期):
		Scale (比例):	1:1
		Revision (版本):	A1
		Sheet (页数):	1 / 1

YONGU 永固

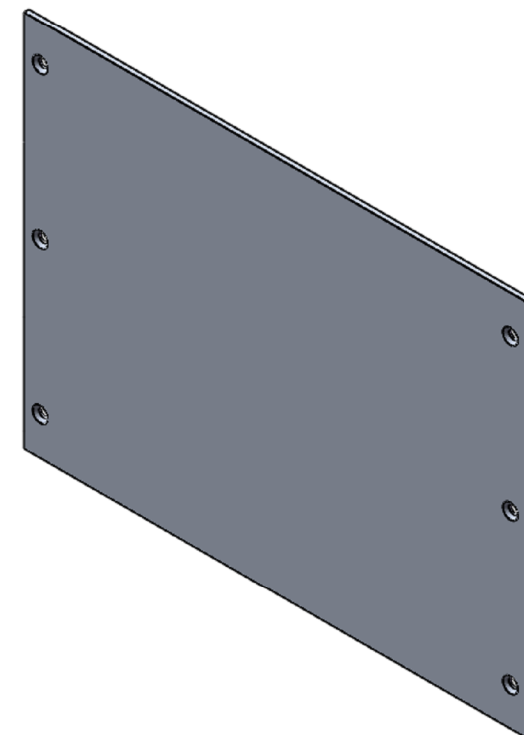
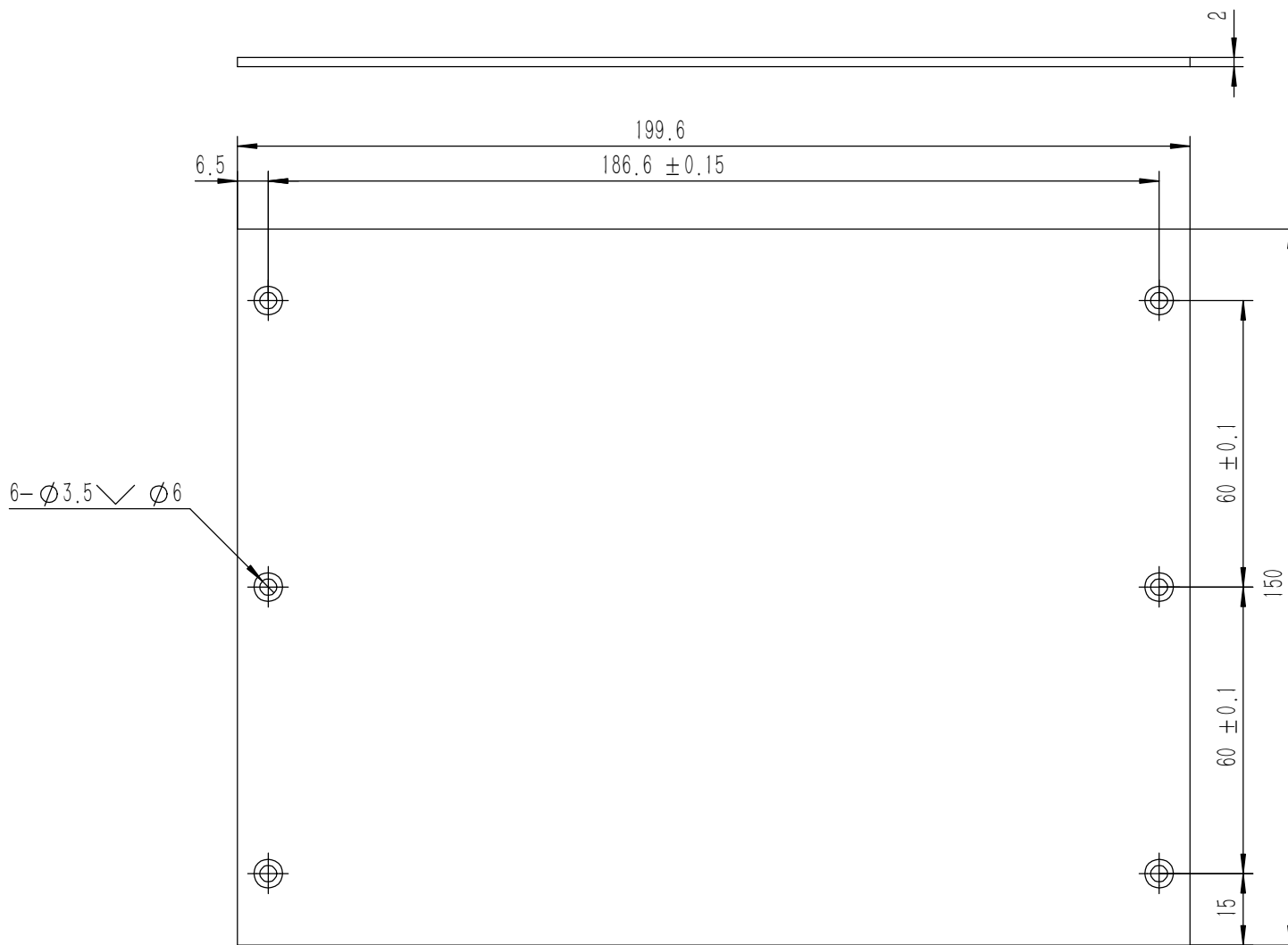

6-∅3.5 √ ∅6

技术要求:

- 1、零件加工表面不应有划痕、擦伤等损伤零件表面的缺陷;
- 2、去除毛刺飞边,锐角倒钝;
- 3、未标注尺寸见3D数模。

Tolerances (未注公差): 0.5 to 6 ± 0.1 6 to 30 ± 0.2 30 to 120 ± 0.3 120 to 400 ± 0.4	Material (材料):	5052-H32		YONGU 永固
	Weight: (重量) (Kg)	0.160		
Break sharp edges (未注锐边倒角): Ch 0.05 to 0.25 x45°	Protection: (表面处理):			Drawing Number (图号): YG-G06C-0000-003
	Part Name (零/部件名称):	底板		
Angular tolerances (未注角度公差): <6° ± 10' <30° ± 20' <120° ± 30' >120° ± 1°	Drawn by (绘图):	莫永康	Date (日期): 2020.05.28	Size (图幅): A3
	Position tolerances (未注位置公差): ±0.05	Check by (校对):	Date (日期):	Scale (比例): 1:1
	Signature by (批准):	Date (日期):	Revision (版本): A1	Sheet (页数): 1 / 1

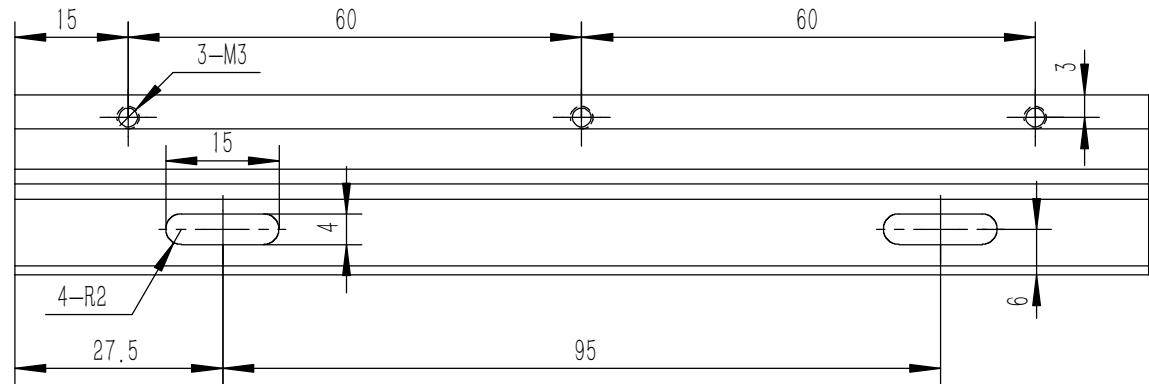
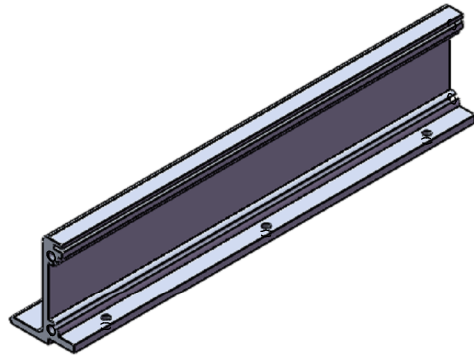
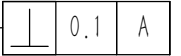
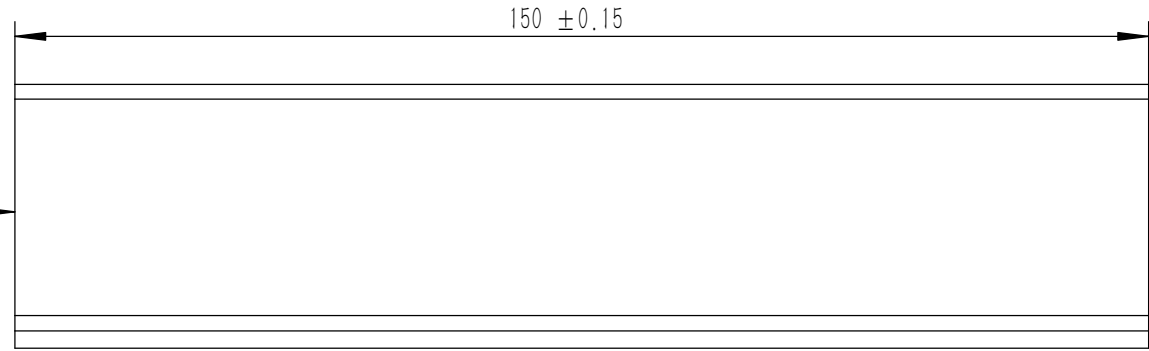
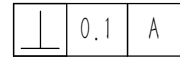
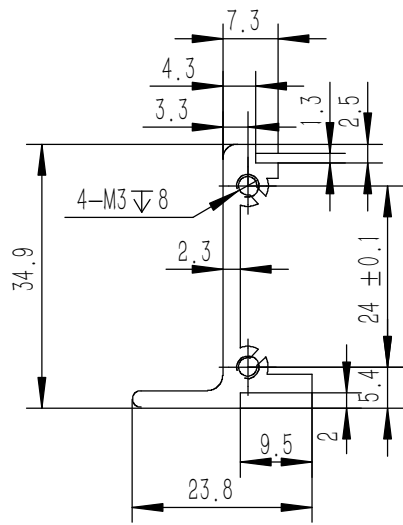

技术要求:

- 1、零件加工表面不应有划痕、擦伤等损伤零件表面的缺陷;
- 2、去除毛刺飞边, 锐角倒钝;
- 3、未标注尺寸见3D数模。

Break sharp edges (未注锐边倒角): Ch 0.05 to 0.25 x45°	Angular tolerances (未注角度公差): <6° ± 10' <30° ± 20' <120° ± 30' >120° ± 1°
Position tolerances (未注位置公差): ± 0.05	

Tolerances (未注公差):	
0.5 to 6 ± 0.1	
6 to 30 ± 0.2	
30 to 120 ± 0.3	
120 to 400 ± 0.4	

Material (材料):	6063-T5
Weight: (重量) (Kg)	0.064
Protection: (表面处理):	
Part Name (零/部件名称):	侧板



Drawn by (绘图):	莫永康	Date (日期):	2020.05.28
Check by (校对):		Date (日期):	
Signature by (批准):		Date (日期):	

Drawing Number (图号):	YG-G06C-0000-004		
Size: (图幅):	A4	Sheet (页数):	1 / 1
Scale (比例):	1:1	Revision (版本):	A1