

25	YG-D04-0000-005	组合侧板	6063-T5	2	0.079	
24	YG-TY-ZSJ-001	螺丝装饰件 M3	5052-H32	8	0.000	
23	YG-D04-0000-006	组合侧板	6063-T5	2	0.193	
22	YG-D04-0000-007	组合侧板	6063-T5	2	0.093	
21	YG-TY-LMT-002	塑料螺母套 M3	ABS	14	0.0001	
20	GB-T-973-1976-C-NI-M3X14	碳钢镀镍十字大扁头螺丝M3X14	普通碳钢	8	0.001	
19	GB-T-819.1-2000-C-NI-M3X6	碳钢镀镍十字沉头螺丝M3X6	普通碳钢	22	0.0004	
18	YG-D04-0000-004	D安装垫板	电解板	1	0.929	
17	YG-D04-0000-001	前后面板	5052-H32	2	0.386	
16	YG-D04-0000-008	D拉手	6063-T5	2	0.084	
15	GB-T-70.1-2000-S-NL-M3X8	不锈钢内六角杯头螺丝M3X8	SUS 304	16	0.001	
14	GB-T-70.3-2000-C-NI-M3X8	芳生镀白镍内六角沉头螺丝M3X8	普通碳钢	8	0.0004	
13	GB-T-39-1988-C-ZI-M3	方螺母镀锌M3	普通碳钢	14	0.0004	
12	YG-D04-0000-009	D后防护	6063-T5	2	0.050	
11	S-M3-1-ZI	压铆螺母镀锌M3X1	普通碳钢	8	0.3750	
10	YG-TY-JJ-003	D后机脚	6063-T5	2	0.028	
9	YG-D04-0000-011	D中间横梁	6063-T5	1	0.134	
8	YG-D04-0000-003	下盖板	5052-H32	1	0.422	
7	YG-TY-JJ-002	D活动机脚	6063-T5	2	0.017	
6	YG-TY-GZ-001	钢珠 D4.7	普通碳钢	2	0.0004	
5	YG-TY-JJ-001	D前机脚座	6063-T5	2	0.023	
4	YG-TY-TH-001	弹簧 0.6X4X20	普通碳钢	2	0.000	
3	GB-T-80-2007-S-NL-M6X10	不锈钢内六角凹端紧定螺钉M6X10	普通碳钢	2	0.0019	
2	YG-D04-0000-010	D前后横梁	6063-T5	4	0.217	
1	YG-D04-0000-002	上盖板	5052-H32	1	0.423	
序号	图号	名称	材料	数量	单重	备注

- 技术要求:
- 1、必须按照设计、工艺要求及本规定和有关标准进行装配;
 - 2、所有零部件(包括外购、外协件)必须具有检验合格证方能进行装配;
 - 3、零件在装配前必须清理和清洗干净,不得有毛刺、飞边、氧化皮、锈蚀、切屑、砂粒、灰尘和油污等,并应符合相应清洁度要求;
 - 4、装配过程中零件不得磕碰、划伤和锈蚀;
 - 5、油漆未干的零件不得进行装配;
 - 6、相对运动的零件,装配时接触面间应加润滑油;
 - 7、各零、部件装配后相对位置应准确。

Break sharp edges (未注锐边倒角): Ch 0.05 to 0.25 x45°	Angular tolerances (未注角度公差): <6° ± 10' <30° ± 20' <120° ± 30' >120° ± 1°
Position tolerances (未注位置公差): ± 0.05	

Tolerances (未注公差): 0.5 to 6 ± 0.1 6 to 30 ± 0.2 30 to 120 ± 0.3 120 to 400 ± 0.4	Material (材料): (装配图)
Weight: (重量) (Kg): 4.737	
Protection: (表面处理):	
Part Name (零/部件名称):	D04机箱
Drawn by (绘图): 邓展锋	Date (日期): 2020.05.23
Check by (校对):	Date (日期):
Signature by (批准):	Date (日期):

YONGU 永固	
Material (材料):	(装配图)
Weight: (重量) (Kg):	4.737
Protection: (表面处理):	
Part Name (零/部件名称):	D04机箱
Drawing Number (图号):	YG-D04-0000-000
Drawn by (绘图):	邓展锋
Check by (校对):	
Signature by (批准):	
Date (日期):	2020.05.23
Date (日期):	
Date (日期):	
Size (图幅):	A0
Scale (比例):	1:1
Revision (版本):	A1
Sheet (页数):	1 / 1

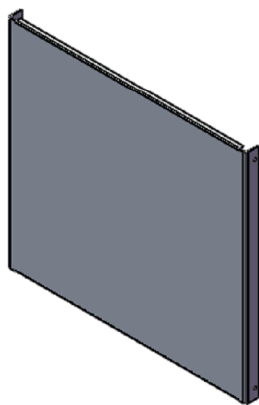
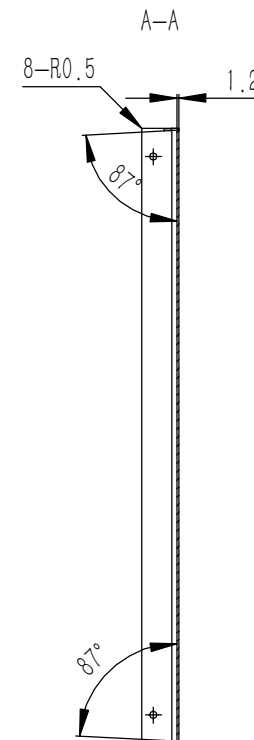
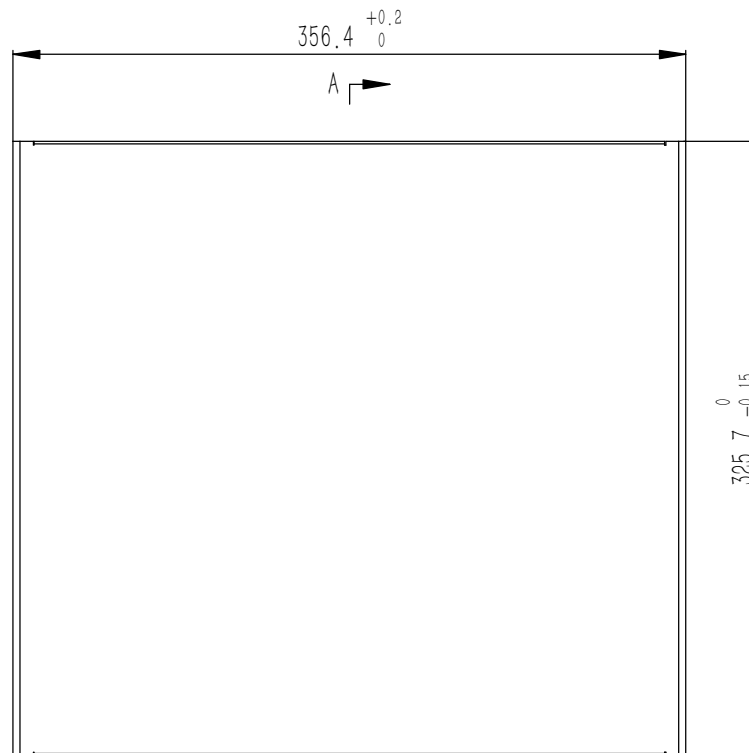
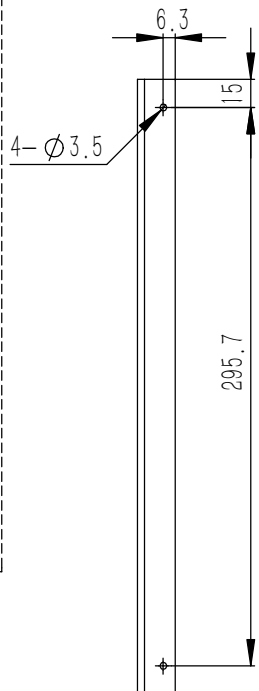
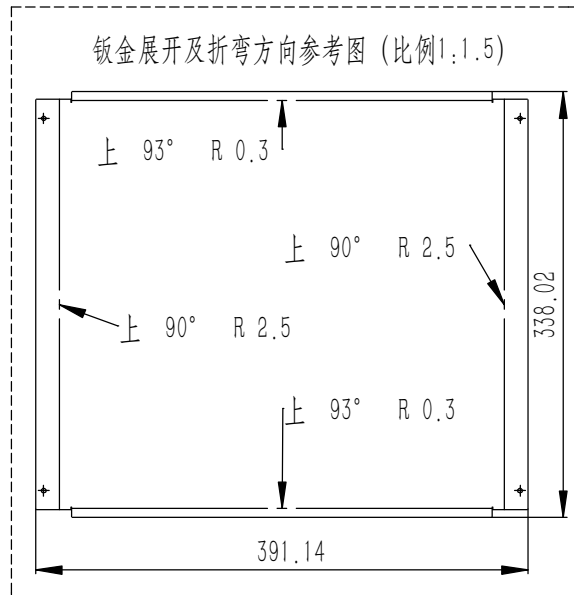
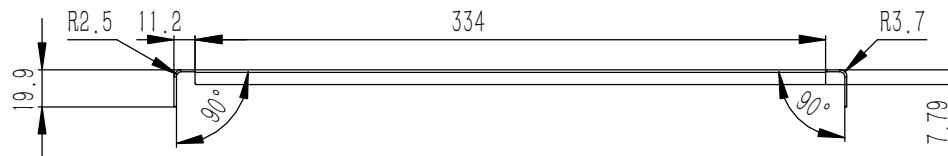

- 技术要求:
- 1、零件加工表面不应有划痕、擦伤等损伤零件表面的缺陷;
 - 2、去除毛刺飞边, 锐角倒钝;
 - 3、未标注尺寸见3D数模。

Tolerances (未注公差):	Material (材料):	5052-H32		YONGU 永固
	0.5 to 6 ± 0.1	Weight: (重量) (Kg):	0.423	
6 to 30 ± 0.2	Protection: (表面处理):			Drawing Number (图号): YG-D04-0000-002
30 to 120 ± 0.3	Part Name (零/部件名称):	上盖板		
120 to 400 ± 0.4	Drawn by (绘图):	莫永康	Date (日期): 2020.05.22	Size (图幅): A0
Break sharp edges (未注锐边倒角): Ch 0.05 to 0.25 x45°	Angular tolerances (未注角度公差):	Check by (校对):	Date (日期):	Scale (比例): 1:1
Position tolerances (未注位置公差): ± 0.05	<6° ± 10' <30° ± 20' <120° ± 30' >120° ± 1°	Signature by (批准):	Date (日期):	Revision (版本): A1
				Sheet (页数): 1 / 1

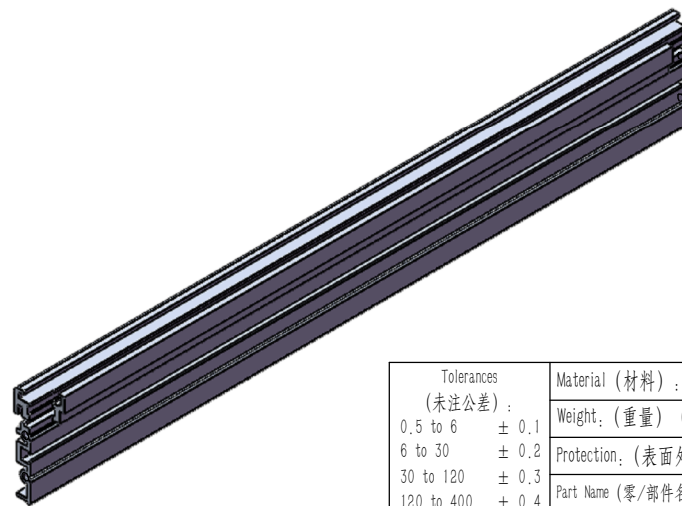
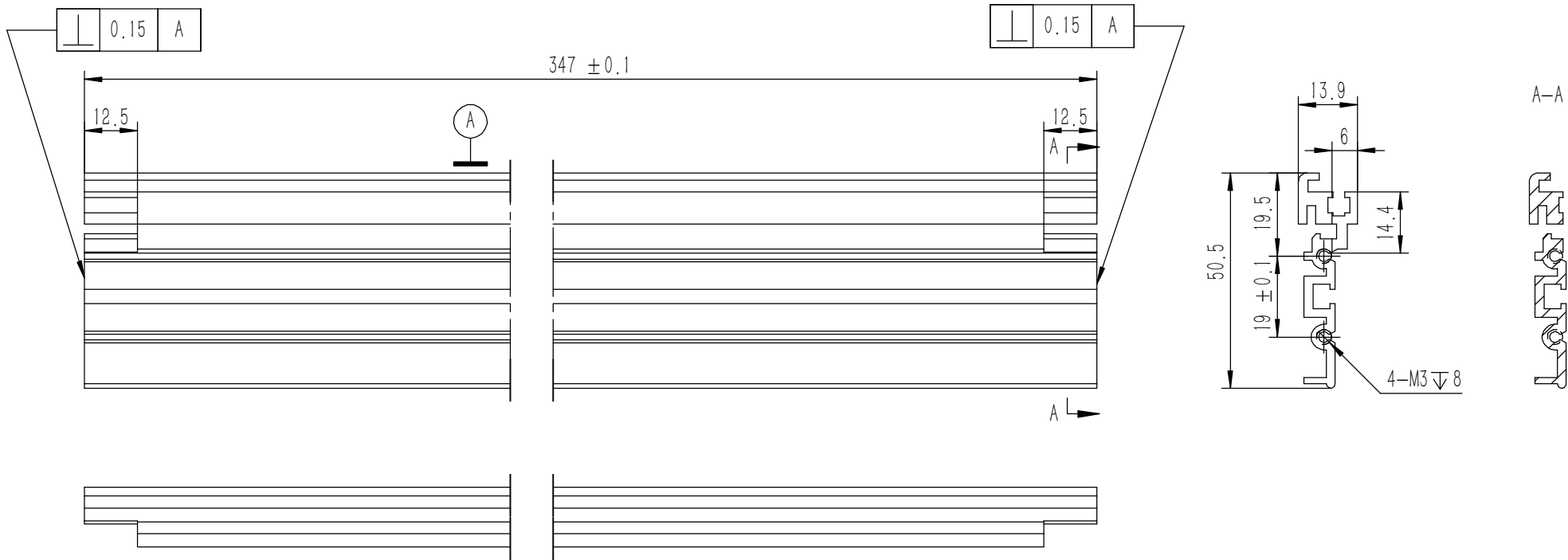

- 技术要求:
- 1、零件加工表面不应有划痕、擦伤等损伤零件表面的缺陷;
 - 2、去除毛刺飞边, 锐角倒钝;
 - 3、未标注尺寸见3D数模。

Tolerances (未注公差): 0.5 to 6 ± 0.1 6 to 30 ± 0.2 30 to 120 ± 0.3 120 to 400 ± 0.4	Material (材料):	6063-T5		YONGU 永固				
	Weight: (重量) (Kg)	0.217						
Break sharp edges (未注锐边倒角): Ch 0.05 to 0.25 x45°	Protection: (表面处理):			Drawing Number (图号): YG-D04-0000-010				
	Part Name (零/部件名称):	D前后横梁						
Position tolerances (未注位置公差): ±0.05	Angular tolerances (未注角度公差): <6° ± 10' <30° ± 20' <120° ± 30' >120° ± 1°	Drawn by (绘图):	邓展锋	Date (日期):	2020.05.22	Size (图幅):	A3	Sheet (页数): 1 / 1
		Check by (校对):		Date (日期):		Scale (比例):	1:1	
		Signature by (批准):		Date (日期):		Revision (版本):		

M6 12底孔 $\phi 5$ 贯穿

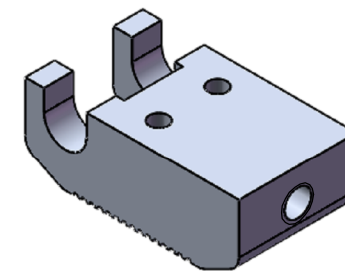
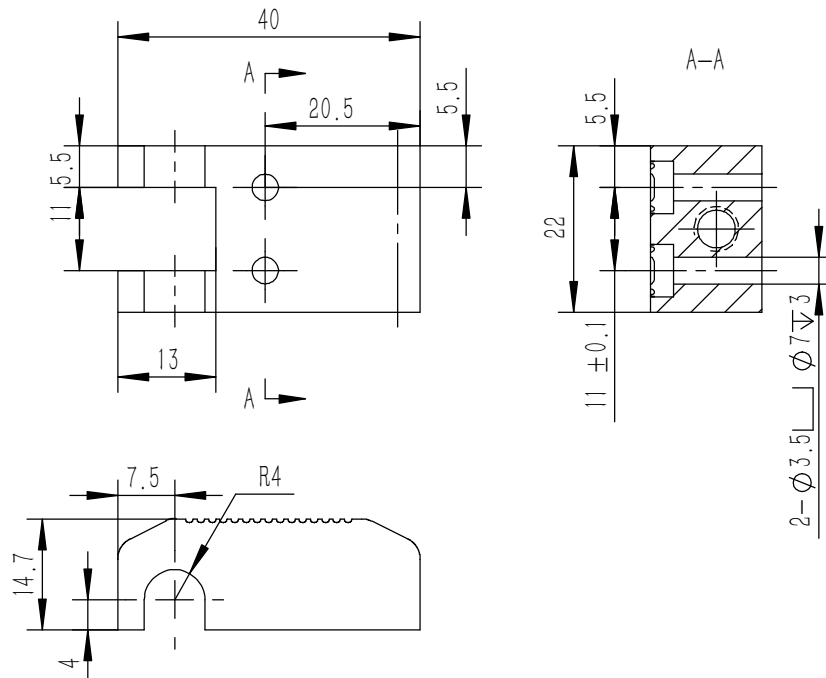
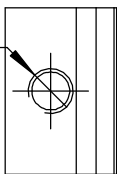

技术要求:

- 1、零件加工表面不应有划痕、擦伤等损伤零件表面的缺陷;
- 2、去除毛刺飞边, 锐角倒钝;
- 3、未标注尺寸见3D数模。

件/套(pcs/set)

Break sharp edges (未注锐边倒角): Ch 0.05 to 0.25 x45°	Angular tolerances (未注角度公差): <6° ± 10' <30° ± 20' <120° ± 30' >120° ± 1°
Position tolerances (未注位置公差): ±0.05	

Tolerances (未注公差): 0.5 to 6 ± 0.1 6 to 30 ± 0.2 30 to 120 ± 0.3 120 to 400 ± 0.4	Material (材料): 6063-T5	YONGU 永固
	Weight: (重量) (Kg) 0.023	
	Protection: (表面处理):	Drawing Number (图号): YG-TY-JJ-001
	Part Name (零/部件名称): D前机脚座	
	Drawn by (绘图): 邓展锋	Date (日期): 2020.05.22
	Check by (校对):	Date (日期):
	Signature by (批准):	Date (日期):
	Size: (图幅): A4	Sheet (页数):
	Scale (比例): 1:1	Revision (版本):
		1 / 1

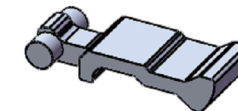
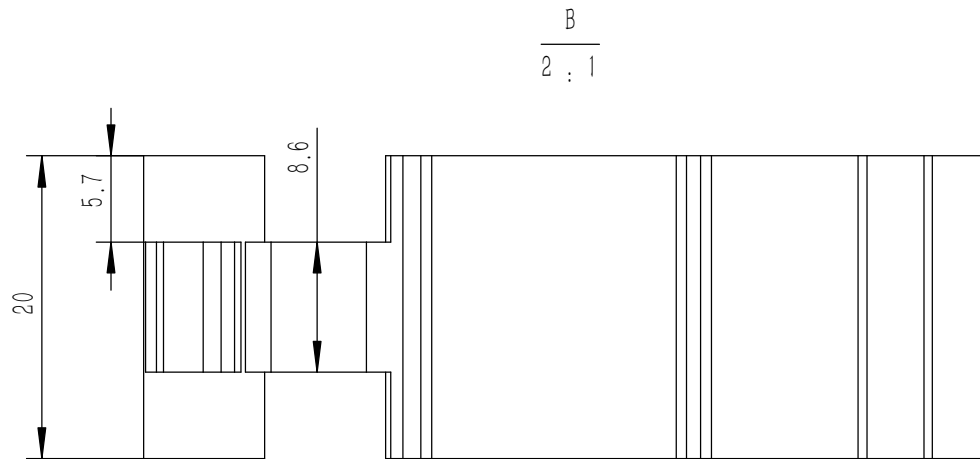
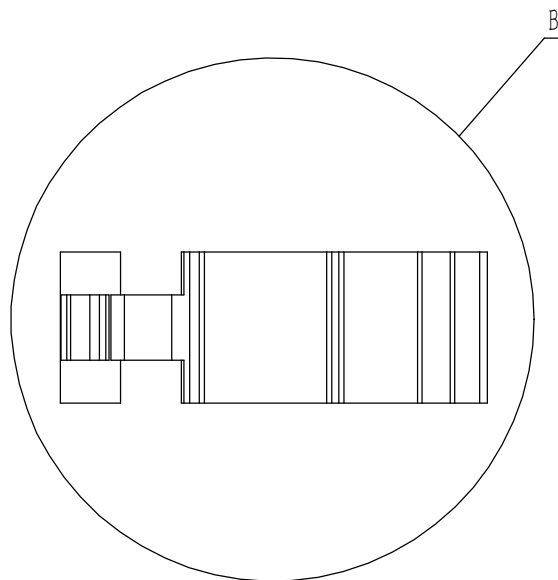
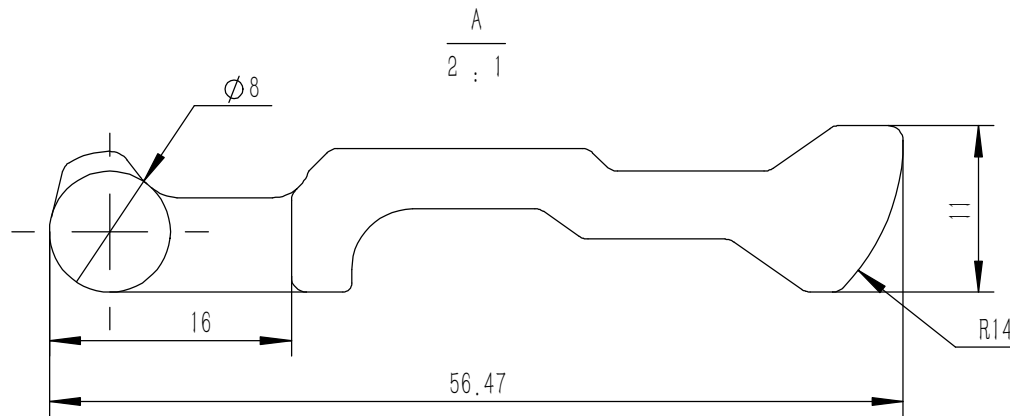
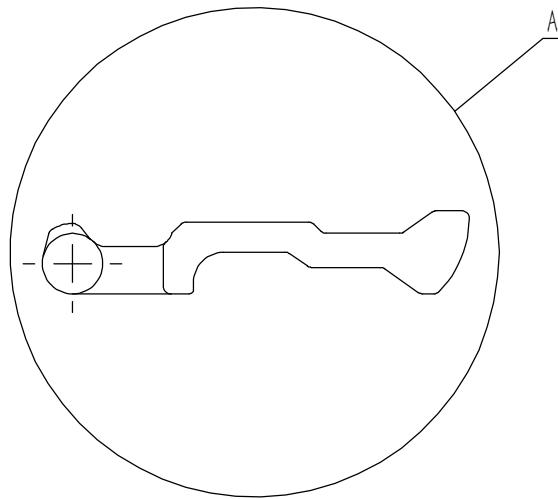

件/套(pcs/set)

Break sharp edges (未注锐边倒角): Ch 0.05 to 0.25 x45°	Angular tolerances (未注角度公差): <math><6^\circ</math> $\pm 10'$ <math><30^\circ</math> $\pm 20'$ <math><120^\circ</math> $\pm 30'$ >120° $\pm 1^\circ$
Position tolerances (未注位置公差): ± 0.05	

Tolerances (未注公差):	
0.5 to 6	± 0.1
6 to 30	± 0.2
30 to 120	± 0.3
120 to 400	± 0.4

Material (材料):	6063-T5
Weight: (重量) (Kg)	0.017
Protection: (表面处理):	
Part Name (零/部件名称):	D活动机脚

YONGU 

Drawing Number (图号):		YG-TY-JJ-002	
Drawn by (绘图):	邓展锋	Date (日期):	2020.05.22
Check by (校对):		Date (日期):	
Signature by (批准):		Date (日期):	
Size: (图幅):	A4	Scale (比例):	1:1
		Sheet (页数):	1 / 1
		Revision (版本):	1 / 1

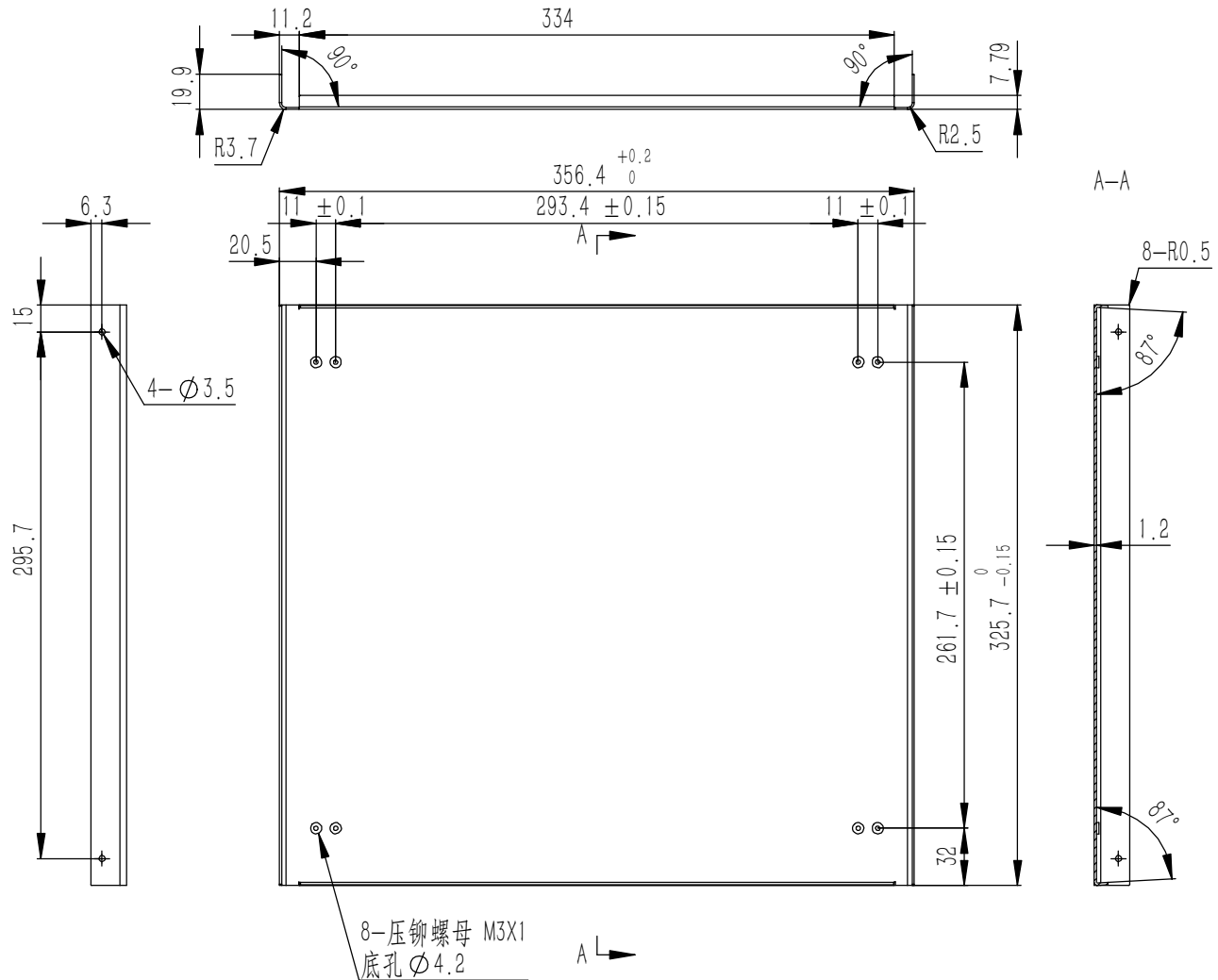
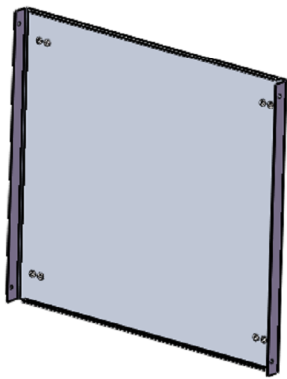
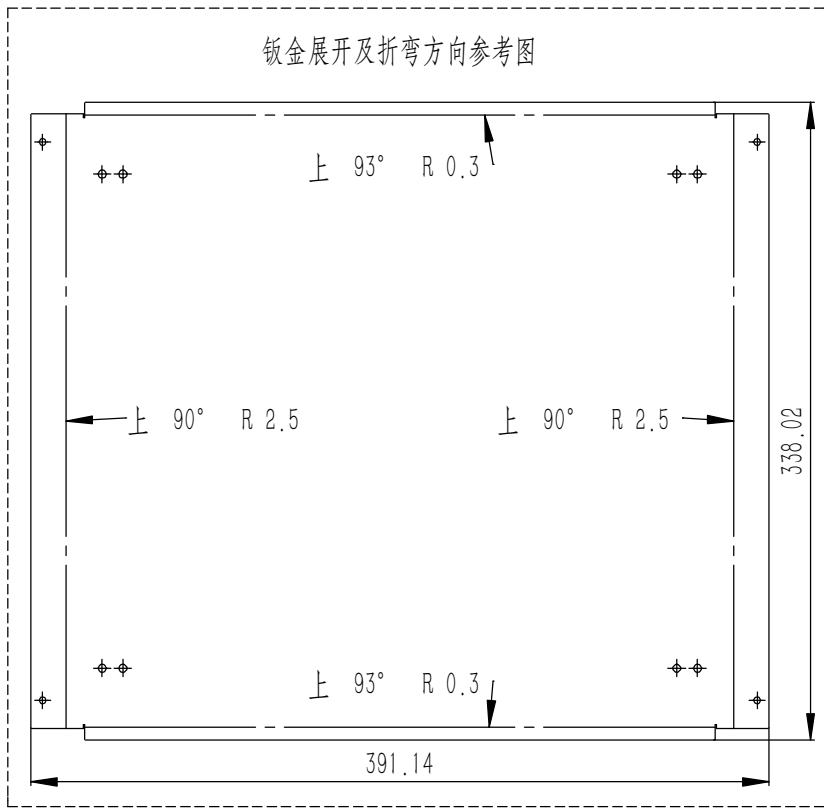

技术要求:

- 1、零件加工表面不应有划痕、擦伤等损伤零件表面的缺陷;
- 2、去除毛刺飞边, 锐角倒钝;
- 3、未标注尺寸见3D数模。

Tolerances (未注公差): 0.5 to 6 ± 0.1 6 to 30 ± 0.2 30 to 120 ± 0.3 120 to 400 ± 0.4	Material (材料):	5052-H32		YONGU 永固
	Weight: (重量) (Kg):	0.425		
	Protection: (表面处理):			
	Part Name (零/部件名称):	下盖板		
Break sharp edges (未注锐边倒角): Ch 0.05 to 0.25 x45°	Angular tolerances (未注角度公差): <6° ± 10' <30° ± 20' <120° ± 30' >120° ± 1°	Drawing Number (图号): YG-D04-0000-003	Size: (图幅): A0	
Position tolerances (未注位置公差): ± 0.05	Drawn by (绘图): 莫永康 Date (日期): 2020.05.22	Date (日期): 2020.05.22	Scale (比例): 1:1	Sheet (页数): 1 / 1
	Signature by (批准):	Date (日期):	Revision (版本): A1	

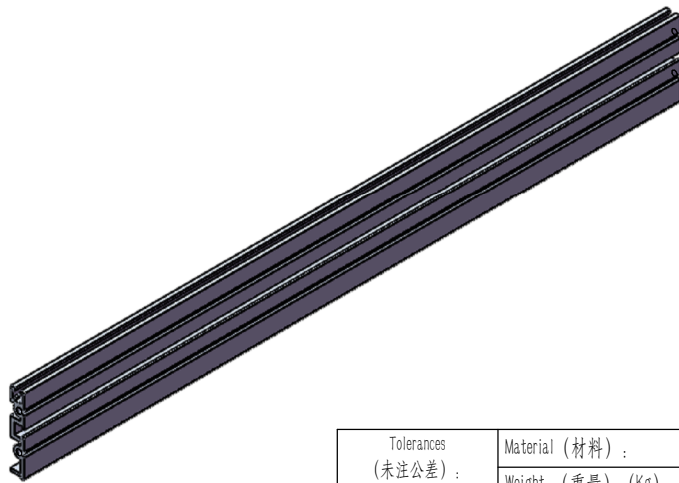
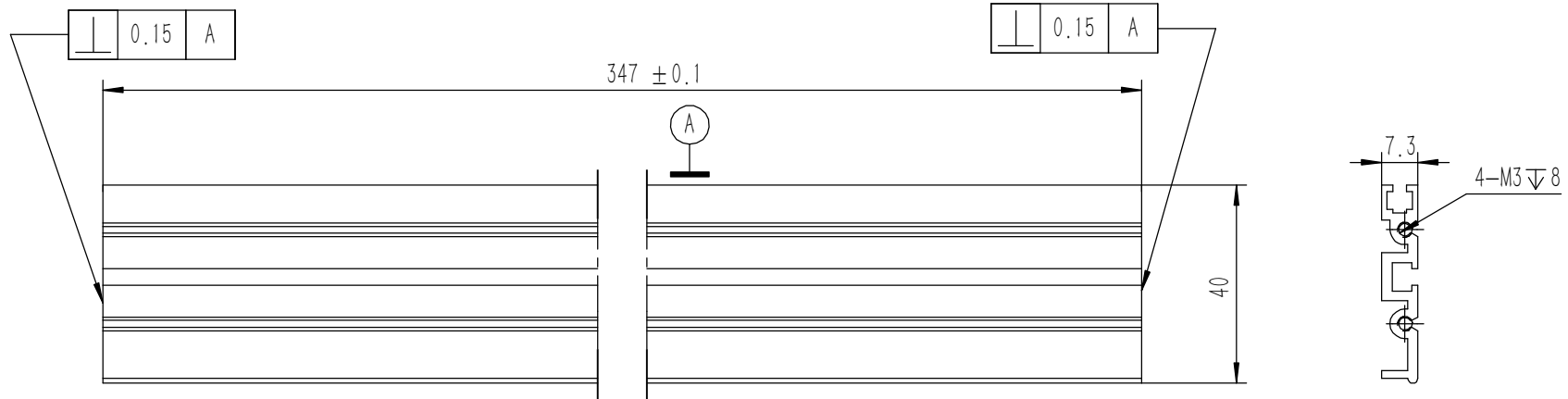

技术要求:

- 1、零件加工表面不应有划痕、擦伤等损伤零件表面的缺陷;
- 2、去除毛刺飞边, 锐角倒钝;
- 3、未标注尺寸见3D数模。

Tolerances (未注公差): 0.5 to 6 ± 0.1 6 to 30 ± 0.2 30 to 120 ± 0.3 120 to 400 ± 0.4	Material (材料):	6063-T5		YONGU 永固				
	Weight: (重量) (Kg)	0.134						
Break sharp edges (未注锐边倒角): Ch 0.05 to 0.25 x45°	Protection: (表面处理):			Drawing Number (图号): YG-D04-0000-011				
	Part Name (零/部件名称):	D中间横梁						
Position tolerances (未注位置公差): ±0.05	Angular tolerances (未注角度公差): <6° ± 10' <30° ± 20' <120° ± 30' >120° ± 1°	Drawn by (绘图):	邓展锋	Date (日期):	2020.05.22	Size. (图幅):	A3	Sheet (页数): 1 / 1
		Check by (校对):		Date (日期):		Scale (比例):	1:1	
		Signature by (批准):		Date (日期):		Revision (版本):		

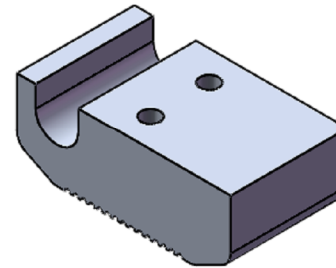
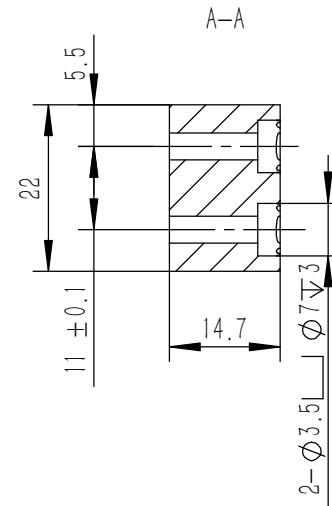
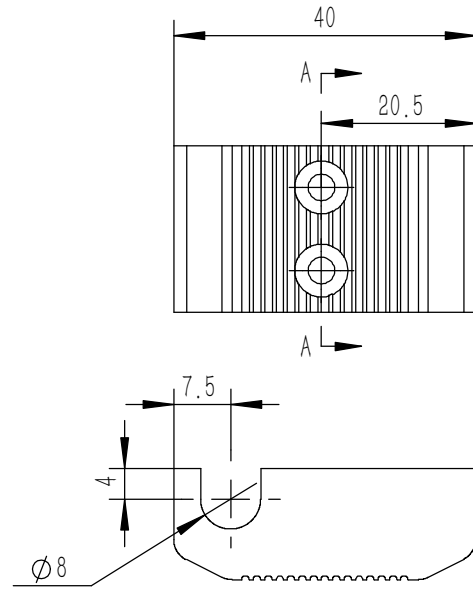

技术要求:

- 1、零件加工表面不应有划痕、擦伤等损伤零件表面的缺陷;
- 2、去除毛刺飞边, 锐角倒钝;
- 3、未标注尺寸见3D数模。

Tolerances (未注公差): 0.5 to 6 ± 0.1 6 to 30 ± 0.2 30 to 120 ± 0.3 120 to 400 ± 0.4	Material (材料):	6063-T5		YONGU 
	Weight: (重量) (Kg)	0.028		
Break sharp edges (未注锐边倒角): Ch 0.05 to 0.25 x45°	Protection: (表面处理):			Drawing Number (图号): YG-TY-JJ-003
	Position tolerances (未注位置公差): ±0.05	Part Name (零/部件名称):	D后机脚	
Angular tolerances (未注角度公差): <6° ± 10' <30° ± 20' <120° ± 30' >120° ± 1°	Part Name (零/部件名称):	D后机脚		Scale (比例): 1:1 Sheet (页数): 1 / 1
	Drawn by (绘图):	邓展锋	Date (日期): 2020.05.22	
	Check by (校对):		Date (日期):	
	Signature by (批准):		Date (日期):	Revision (版本): 1 / 1

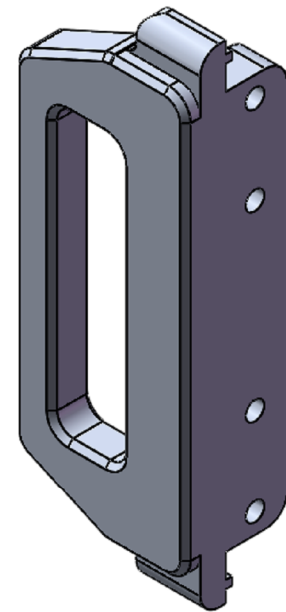
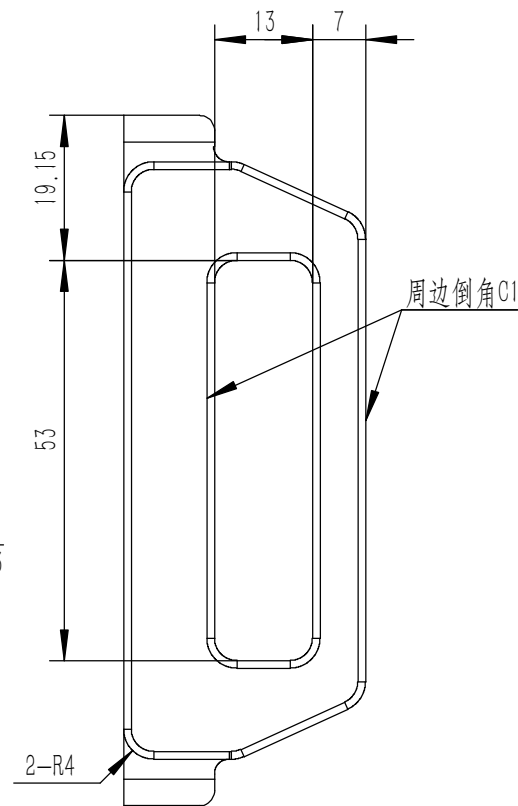
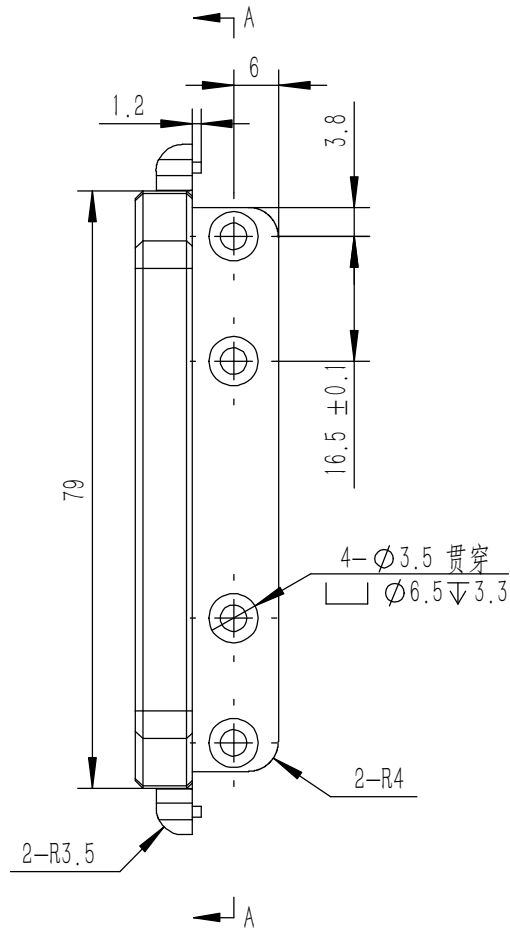
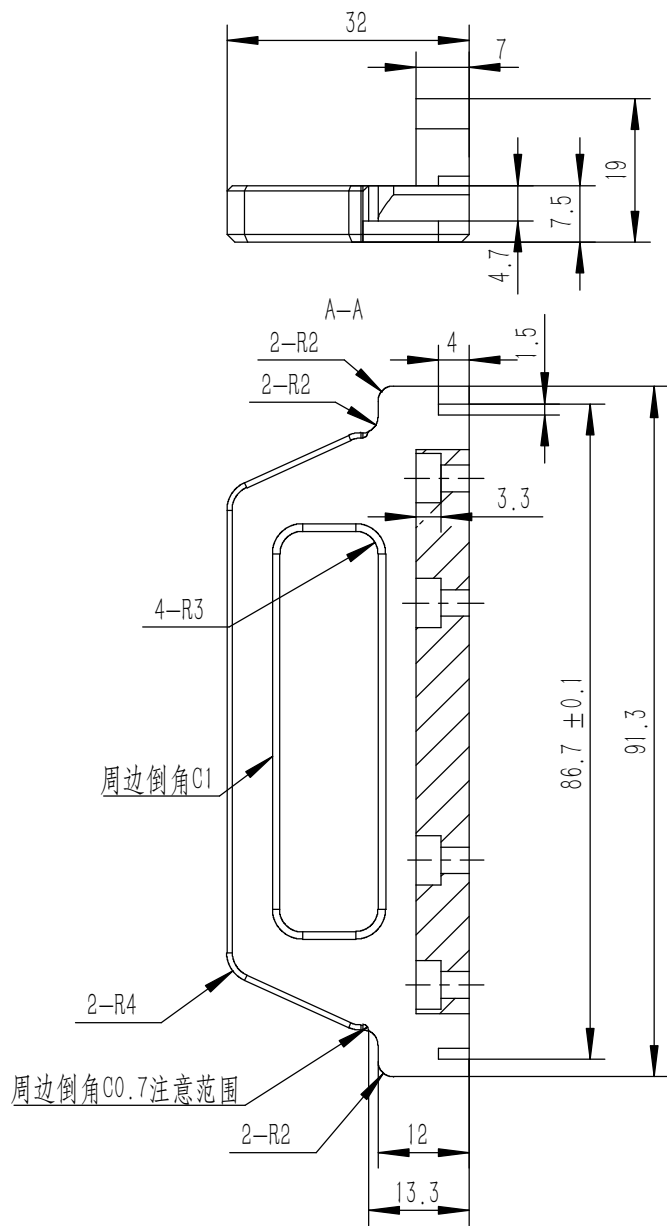

技术要求:

- 1、零件加工表面不应有划痕、擦伤等损伤零件表面的缺陷;
- 2、去除毛刺飞边, 锐角倒钝;
- 3、未标注尺寸见3D数模。

Break sharp edges (未注锐边倒角): Ch 0.05 to 0.25 x45°	Angular tolerances (未注角度公差): <6° ± 10' <30° ± 20' <120° ± 30' >120° ± 1°
Position tolerances (未注位置公差): ±0.05	

Tolerances (未注公差): 0.5 to 6 ± 0.1 6 to 30 ± 0.2 30 to 120 ± 0.3 120 to 400 ± 0.4	Material (材料): 6063-T5	YONGU 永固		
	Weight: (重量) (Kg) 0.050			
	Protection: (表面处理):	Drawing Number (图号): YG-D04-0000-009		
	Part Name (零/部件名称): D后防护			
	Drawn by (绘图): 邓展锋	Date (日期): 2020.05.14	Size: (图幅): A4	Sheet (页数): 1 / 1
	Check by (校对):	Date (日期):	Scale (比例): 1:1	
	Signature by (批准):	Date (日期):	Revision (版本): A1	

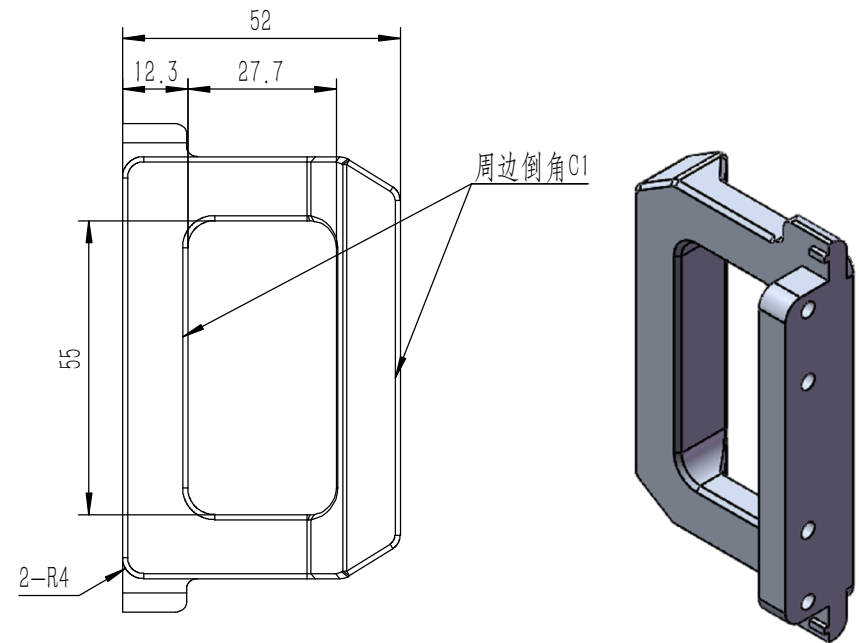
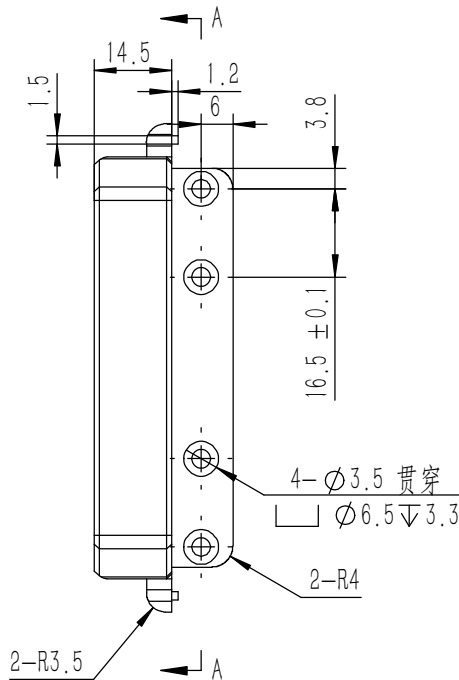
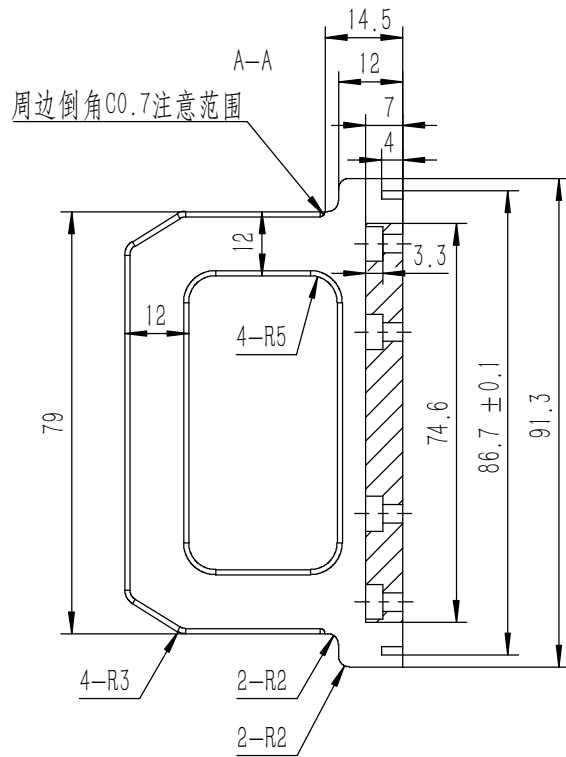
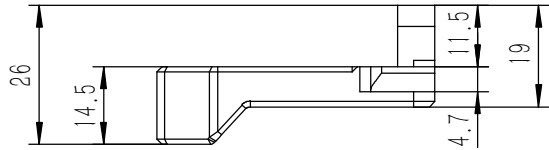

技术要求:

- 1、零件加工表面不应有划痕、擦伤等损伤零件表面的缺陷;
- 2、去除毛刺飞边,锐角倒钝;
- 3、未标注尺寸见3D数模。

Tolerances (未注公差): 0.5 to 6 ± 0.1 6 to 30 ± 0.2 30 to 120 ± 0.3 120 to 400 ± 0.4	Material (材料):	6063-T5		YONGU 永固
	Weight: (重量) (Kg)	0.084		
Break sharp edges (未注锐边倒角): Ch 0.05 to 0.25 x45°	Protection: (表面处理):			Drawing Number (图号): YG-D04-0000-008
	Position tolerances (未注位置公差): ±0.05	Part Name (零/部件名称):	D拉手	
Angular tolerances (未注角度公差): <6° ± 10' <30° ± 20' <120° ± 30' >120° ± 1°	Drawn by (绘图):	邓展锋	Date (日期): 2020.05.22	Size (图幅): A3
	Signature by (批准):		Date (日期):	Scale (比例): 1:1
	Sheet (页数):	1 / 1		

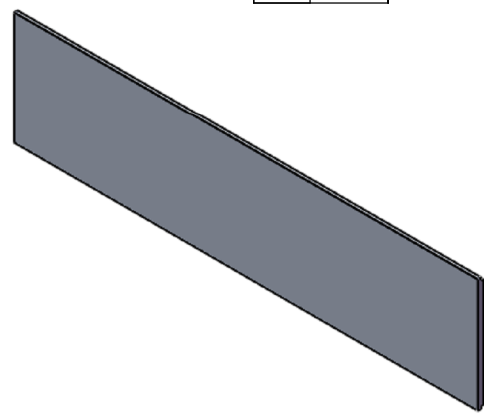
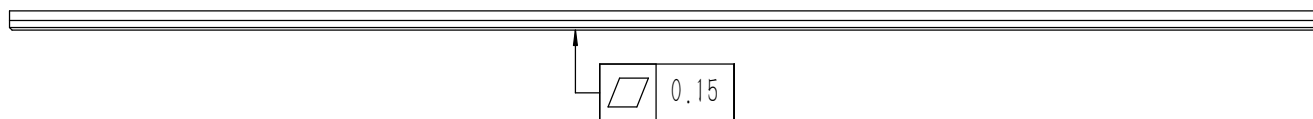
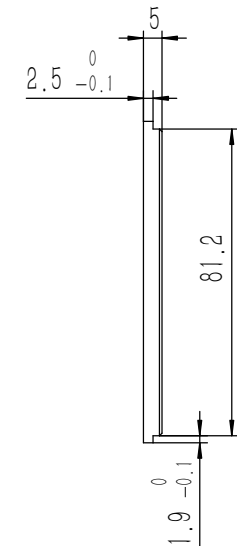
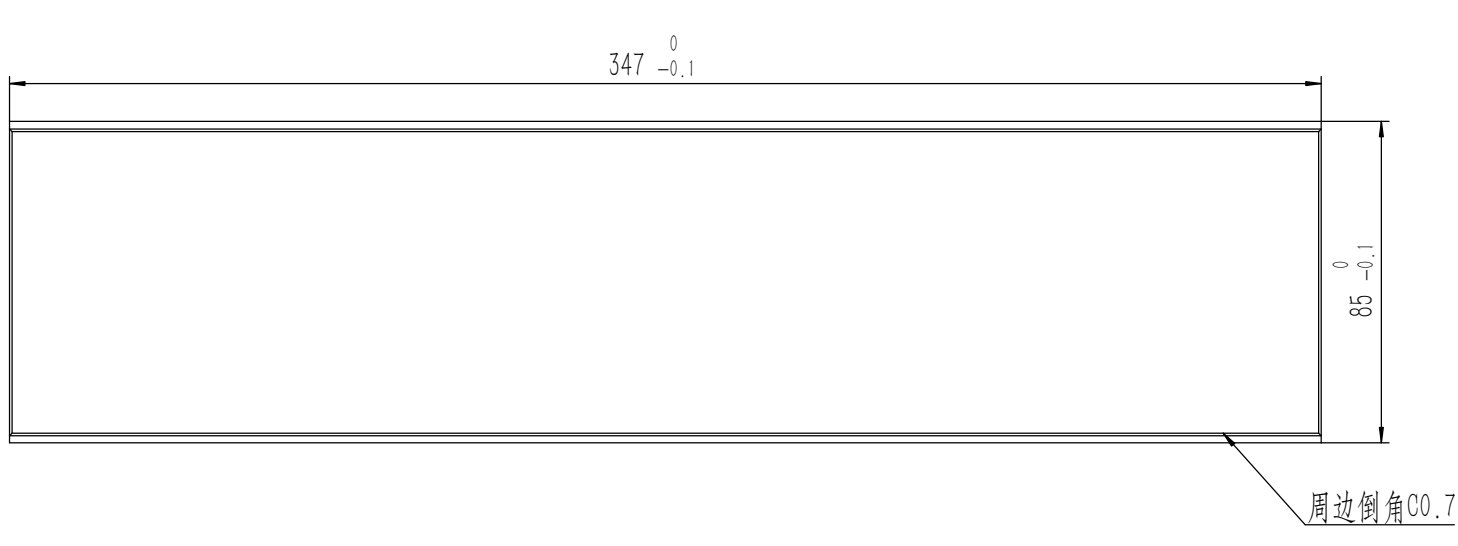

技术要求:
 1、零件加工表面不应有划痕、擦伤等损伤零件表面的缺陷;
 2、去除毛刺飞边, 锐角倒钝;
 3、未标注尺寸见3D数模。

Break sharp edges (未注锐边倒角): Ch 0.05 to 0.25 x45°	Angular tolerances (未注角度公差): <6° ± 10' <30° ± 20' <120° ± 30' >120° ± 1°
Position tolerances (未注位置公差): ±0.05	

Tolerances (未注公差):		Material (材料):	5052-H32	YONGU 永固
0.5 to 6	± 0.1	Weight: (重量) (Kg):	0.386	
6 to 30	± 0.2	Protection: (表面处理):		
30 to 120	± 0.3	Part Name (零/部件名称):		Drawing Number (图号):
120 to 400	± 0.4	前后面板		YG-D04-0000-001
		Drawn by (绘图):	莫永康	Date (日期):
		Date (日期):	2020.05.22	Size: (图幅):
		Check by (校对):		Date (日期):
		Date (日期):		Scale (比例):
		Signature by (批准):		Date (日期):
		Date (日期):		Revision (版本):
				Sheet (页数):
				1 / 1

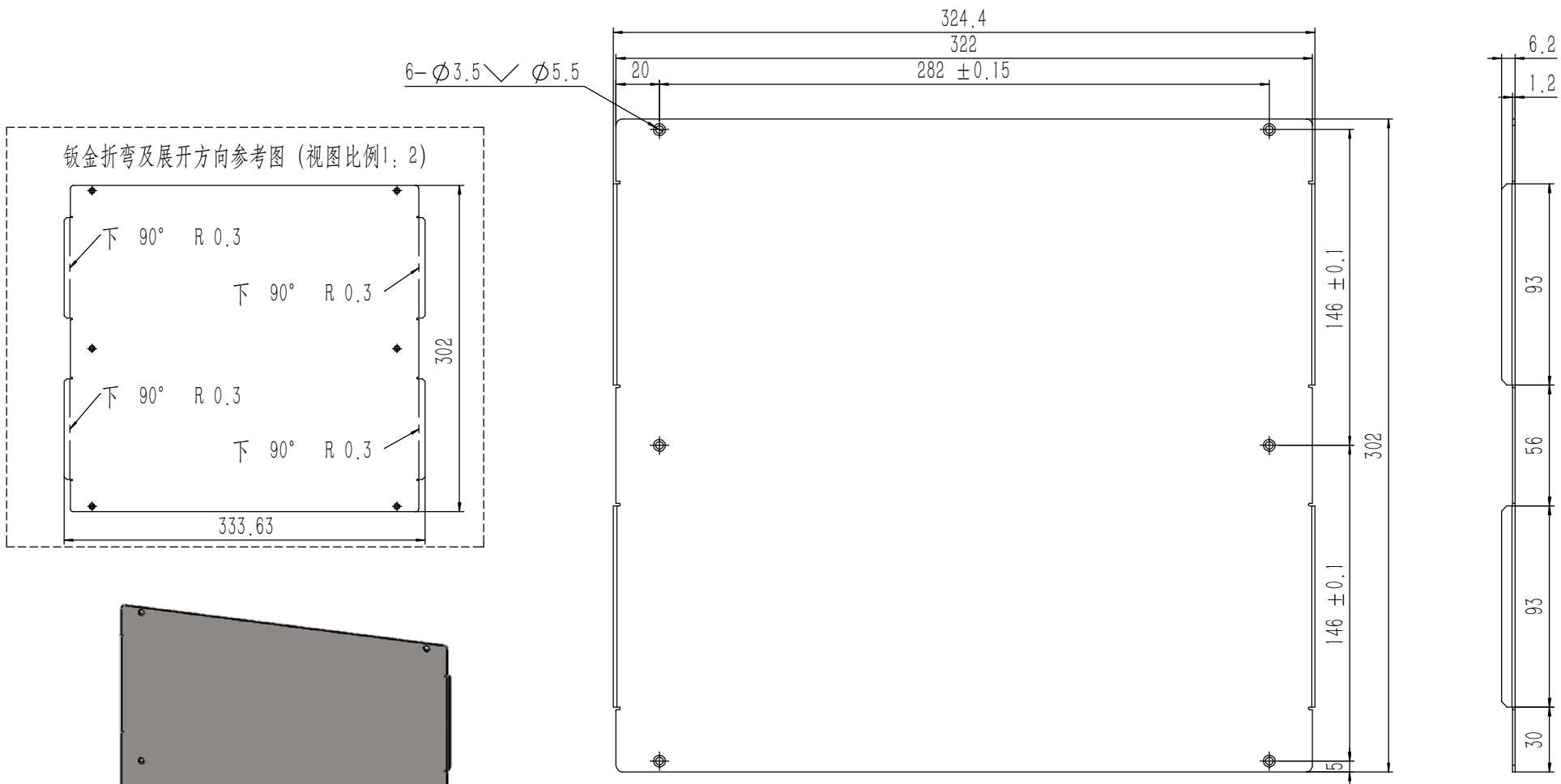

技术要求:

- 1、零件加工表面不应有划痕、擦伤等损伤零件表面的缺陷;
- 2、去除毛刺飞边,锐角倒钝;
- 3、未标注尺寸见3D数模。

Tolerances (未注公差): 0.5 to 6 ± 0.1 6 to 30 ± 0.2 30 to 120 ± 0.3 120 to 400 ± 0.4	Material (材料):	电解板			
	Weight: (重量) (Kg):	0.929			
Protection: (表面处理):					
Break sharp edges (未注锐边倒角): Ch 0.05 to 0.25 x45°	Angular tolerances (未注角度公差): <6° ± 10' <30° ± 20' <120° ± 30' >120° ± 1°	Part Name (零/部件名称):	D安装垫板	Drawing Number (图号):	YG-D04-0000-004
Position tolerances (未注位置公差): ± 0.05		Drawn by (绘图):	邓展锋	Date (日期):	2020.05.22
		Check by (校对):		Date (日期):	
		Signature by (批准):		Date (日期):	
				Size: (图幅):	A1
				Scale (比例):	1:1
				Revision (版本):	
				Sheet (页数):	1 / 1

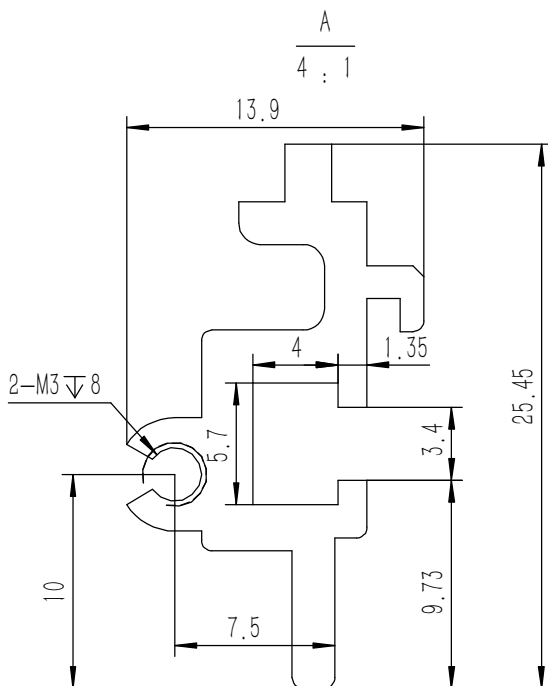
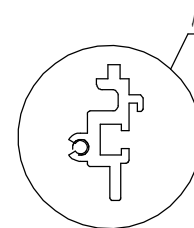
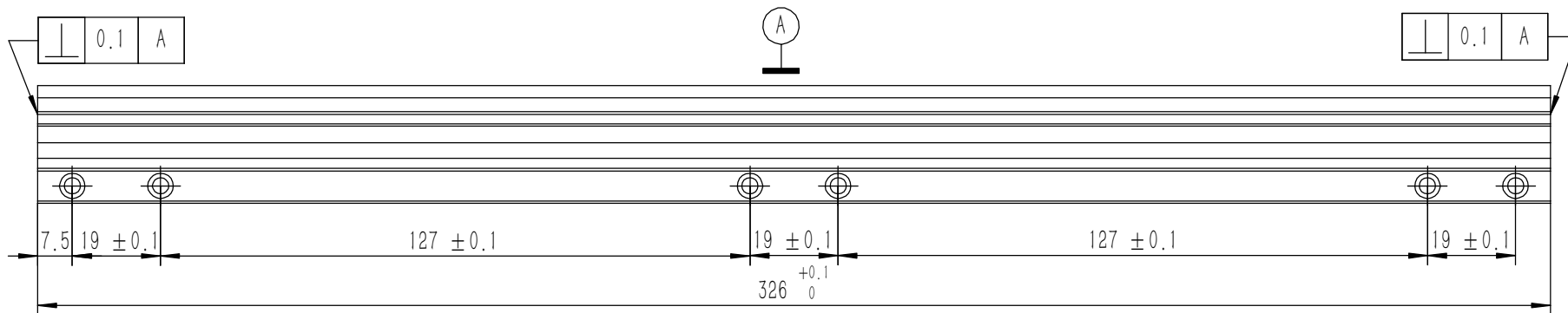

技术要求:

- 1、零件加工表面不应有划痕、擦伤等损伤零件表面的缺陷;
- 2、去除毛刺飞边, 锐角倒钝;
- 3、未标注尺寸见3D数模。

Tolerances (未注公差): 0.5 to 6 ± 0.1 6 to 30 ± 0.2 30 to 120 ± 0.3 120 to 400 ± 0.4	Material (材料):	6063-T5	YONGU 永固				
	Weight: (重量) (Kg)	0.093					
Break sharp edges (未注锐边倒角): Ch 0.05 to 0.25 x45°	Protection: (表面处理):		Drawing Number (图号): YG-D04-0000-007				
	Position tolerances (未注位置公差): ±0.05	Part Name (零/部件名称): 组合侧板					
Angular tolerances (未注角度公差): <6° ± 10' <30° ± 20' <120° ± 30' >120° ± 1°	Drawn by (绘图):	莫永康	Date (日期):	2020.05.22	Size (图幅):	A3	Sheet (页数): 1 / 1
	Check by (校对):		Date (日期):		Scale (比例):	1:1	
	Signature by (批准):		Date (日期):		Revision (版本):	A1	

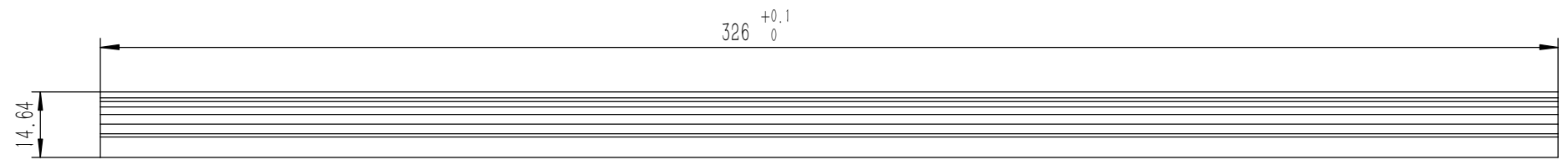
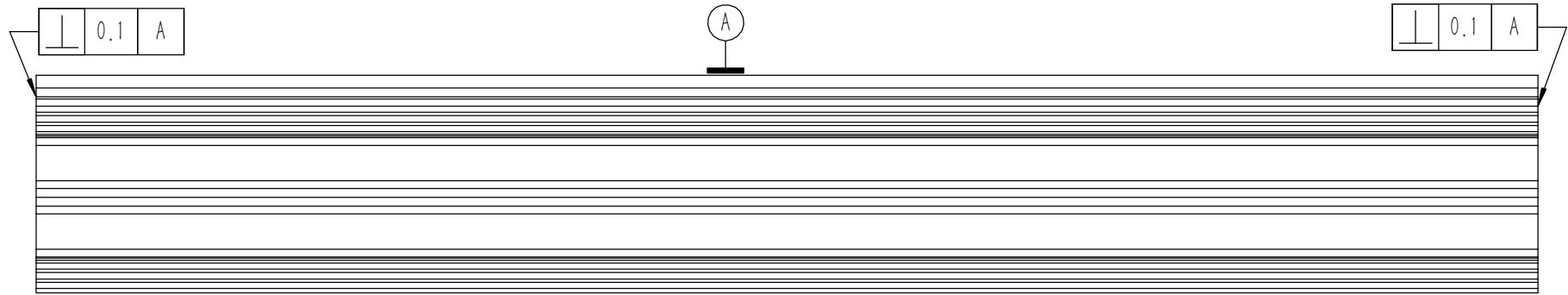
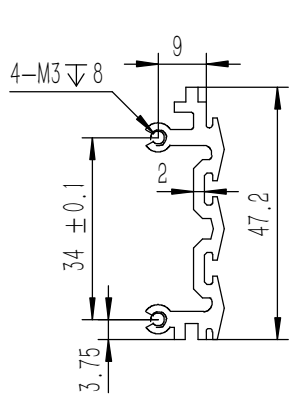

技术要求:
 1、零件加工表面不应有划痕、擦伤等损伤零件表面的缺陷;
 2、去除毛刺飞边,锐角倒钝;
 3、未标注尺寸见3D数模。

Break sharp edges (未注锐边倒角): Ch 0.05 to 0.25 x45°	Angular tolerances (未注角度公差): <6° ± 10' <30° ± 20' <120° ± 30' >120° ± 1°
Position tolerances (未注位置公差): ±0.05	

Tolerances (未注公差): 0.5 to 6 ± 0.1 6 to 30 ± 0.2 30 to 120 ± 0.3 120 to 400 ± 0.4	Material (材料): 6063-T5
	Weight: (重量) (Kg) 0.193
	Protection: (表面处理):
	Part Name (零/部件名称): 组合侧板
Drawn by (绘图): 莫永康	Date (日期): 2020.05.22
Check by (校对):	Date (日期):
Signature by (批准):	Date (日期):

YONGU 永固	Drawing Number (图号): YG-D04-0000-006
	Size (图幅): A3
Scale (比例): 1:1	Sheet (页数): 1 / 1
Revision (版本): A1	

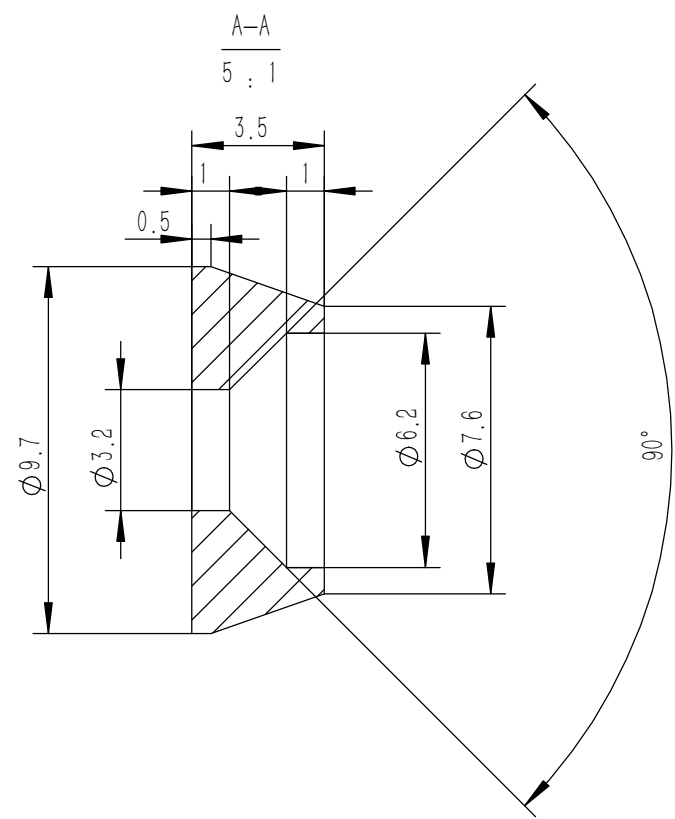
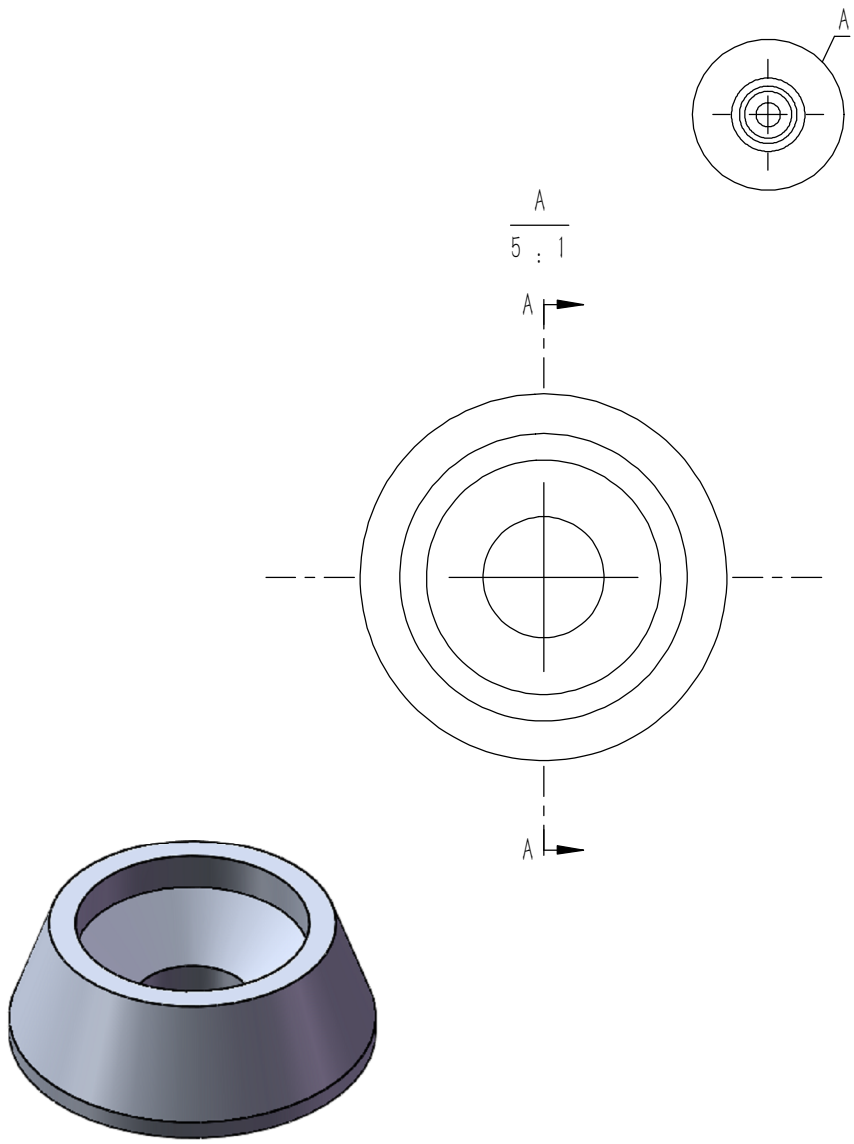

技术要求:

- 1、零件加工表面不应有划痕、擦伤等损伤零件表面的缺陷;
- 2、去除毛刺飞边, 锐角倒钝;
- 3、未标注尺寸见3D数模。

Tolerances (未注公差): 0.5 to 6 ± 0.1 6 to 30 ± 0.2 30 to 120 ± 0.3 120 to 400 ± 0.4	Material (材料):	5052-H32		YONGU 永固
	Weight: (重量) (Kg)	0.000		
Break sharp edges (未注锐边倒角): Ch 0.05 to 0.25 x45°	Protection: (表面处理):			Drawing Number (图号): YG-TY-ZSJ-001
	Position tolerances (未注位置公差): ±0.05	Part Name (零/部件名称):	螺丝装饰件 M3	
Angular tolerances (未注角度公差): <6° ± 10' <30° ± 20' <120° ± 30' >120° ± 1°	Drawn by (绘图):	莫永康	Date (日期): 2020.05.22	Size: (图幅): A4
	Check by (校对):		Date (日期):	Scale (比例): 1:1
	Signature by (批准):		Date (日期):	Revision (版本): A1
				Sheet (页数): 1 / 1

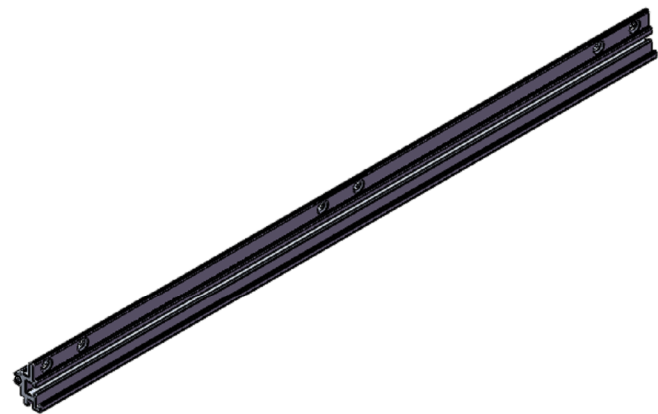
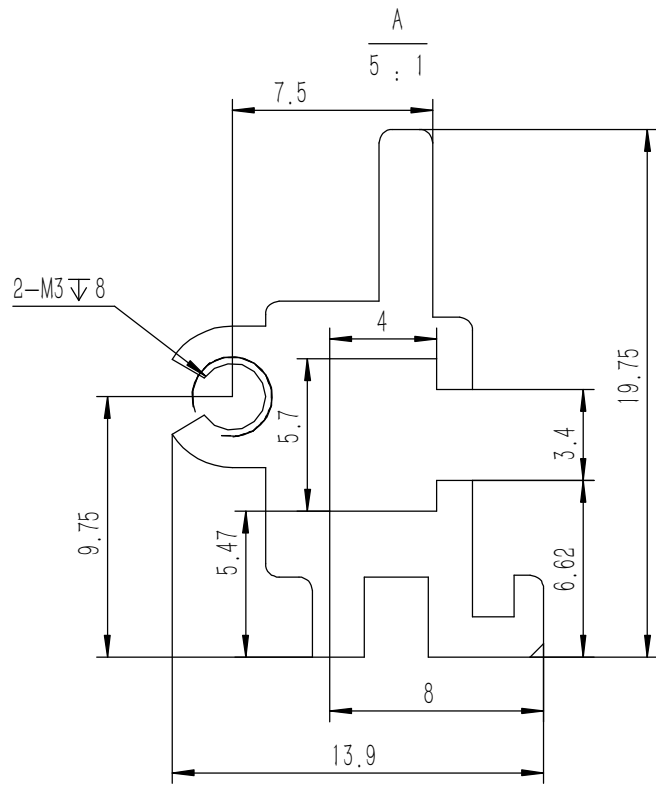
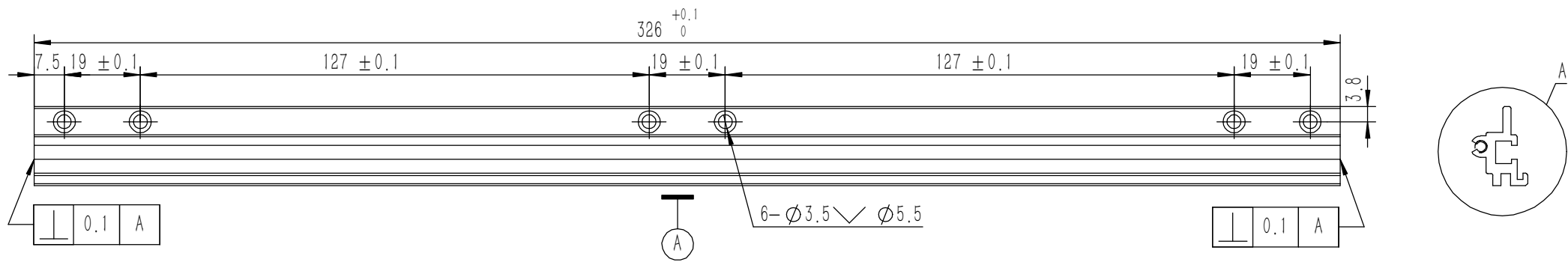

技术要求:
 1、零件加工表面不应有划痕、擦伤等损伤零件表面的缺陷;
 2、去除毛刺飞边,锐角倒钝;
 3、未标注尺寸见3D数模。

Tolerances (未注公差): 0.5 to 6 ± 0.1 6 to 30 ± 0.2 30 to 120 ± 0.3 120 to 400 ± 0.4	Material (材料):	6063-T5	YONGU 永固				
	Weight: (重量) (Kg)	0.079					
Break sharp edges (未注锐边倒角): Ch 0.05 to 0.25 x45°	Protection: (表面处理):		Drawing Number (图号): YG-D04-0000-005				
	Position tolerances (未注位置公差): ±0.05	Part Name (零/部件名称): 组合侧板					
Angular tolerances (未注角度公差): <6° ± 10' <30° ± 20' <120° ± 30' >120° ± 1°	Drawn by (绘图):	莫永康	Date (日期):	2020.05.22	Size (图幅):	A3	Sheet (页数): 1 / 1
	Check by (校对):		Date (日期):		Scale (比例):	1:1	
	Signature by (批准):		Date (日期):		Revision (版本):	A1	