

8	GB-T-70.1-2000-C-BE-M3X8	碳钢发黑内六角杯头螺丝M3X8	普通碳钢	16	0.001	
7	YG-S-1-06	黑色小包角	黑色 TPE 90A	8	0.014	
6	GB-T-39-1988-C-ZI-M3	方螺母镀白锌M3	普通碳钢	8	0.0004	
5	GB-T-70.3-2000-C-NB-M3X6	芳生镀黑镍内六角沉头螺丝M3X6	普通碳钢	8	0.0004	
4	YG-TY-LMT-002	塑料螺母套 M3	ABS	8	0.0001	
3	YG-S104-0000-003	挡板	5052-H32	2	0.075	
2	YG-S104-0000-002	上下盖板	5052-H32	2	0.427	
1	YG-S104-0000-001	连接条	6063-T5	2	0.026	

序号 (Item)	图号 (Drawing Number)	名称 (Part Name)	材料 (Material)	数量 (QTY)	单重 (Weight)	备注 (Note)
Tolerances (未注公差):		Material (材料): (装配图)		YONGU 永固		
0.5 to 6 ± 0.1		Weight: (重量) (Kg): 1.186				
6 to 30 ± 0.2		Protection: (表面处理):		Drawing Number (图号):		
30 to 120 ± 0.3		Part Name (零/部件名称):		YG-S104-0000-000		
120 to 400 ± 0.4		S104小包角机箱		Size: (图幅): A1		
Break sharp edges (未注锐边倒角):		Drawn by (绘图): 江瑞章		Date (日期): 2021.06.03		Sheet (页数):
Ch 0.05 to 0.25 x45°		Check by (校对):		Date (日期):		1 / 1
Position tolerances (未注位置公差): ±0.05		Signature by (批准):		Date (日期):		Revision (版本): A1
Angular tolerances (未注角度公差):						
<6° ± 10'						
<30° ± 20'						
<120° ± 30'						
>120° ± 1°						

技术要求:

- 1、必须按照设计、工艺要求及本规定和有关标准进行装配;
- 2、所有零部件(包括外购、外协件)必须具有检验合格证方能进行装配;
- 3、零件在装配前必须清理和清洗干净,不得有毛刺、飞边、氧化皮、锈蚀、切屑、砂粒、灰尘和油污等,并应符合相应清洁度要求;
- 4、装配过程中零件不得磕碰、划伤和锈蚀;
- 5、油漆未干的零件不得进行装配;
- 6、相对运动的零件,装配时接触面间应加润滑油脂;
- 7、各零、部件装配后相对位置应准确。

业务代码: 250-80

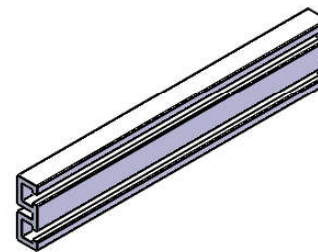
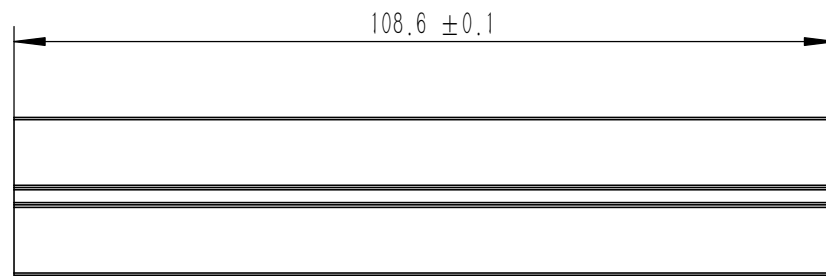
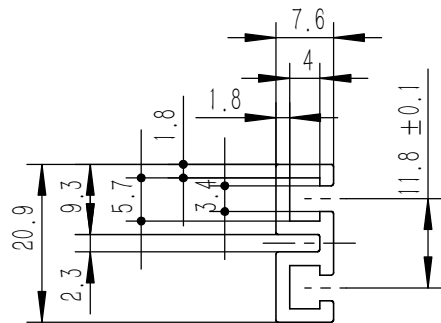

技术要求:

- 1、未注倒角R0.3, 未标锐边的倒角不超R0.1
- 2、零件加工表面不应有划痕、擦伤等损伤零件表面的缺陷;
- 3、未标注尺寸见电子档图纸

业务代码: 250-80

Tolerances (未注公差): 0.5 to 6 ± 0.1 6 to 30 ± 0.2 30 to 120 ± 0.3 120 to 400 ± 0.4	Material (材料): 6063-T5	YONGU 永固		
	Weight: (重量) (Kg) 0.026			Protection: (表面处理):
Break sharp edges (未注锐边倒角): Ch 0.05 to 0.25 x45°	Part Name (零/部件名称): 连接条		Drawing Number (图号): YG-S104-0000-001	
	Angular tolerances (未注角度公差): <6° ± 10' <30° ± 20' <120° ± 30' >120° ± 1°	Drawn by (绘图): 江瑞章	Date (日期): 2021.06.03	Size: (图幅): A4
Position tolerances (未注位置公差): ±0.05	Check by (校对):	Date (日期):	Scale (比例): 1:1	Sheet (页数): 1 / 1
	Signature by (批准):	Date (日期):	Revision (版本): A1	

钣金展开及折弯方向参考图 (视图比例1:1)

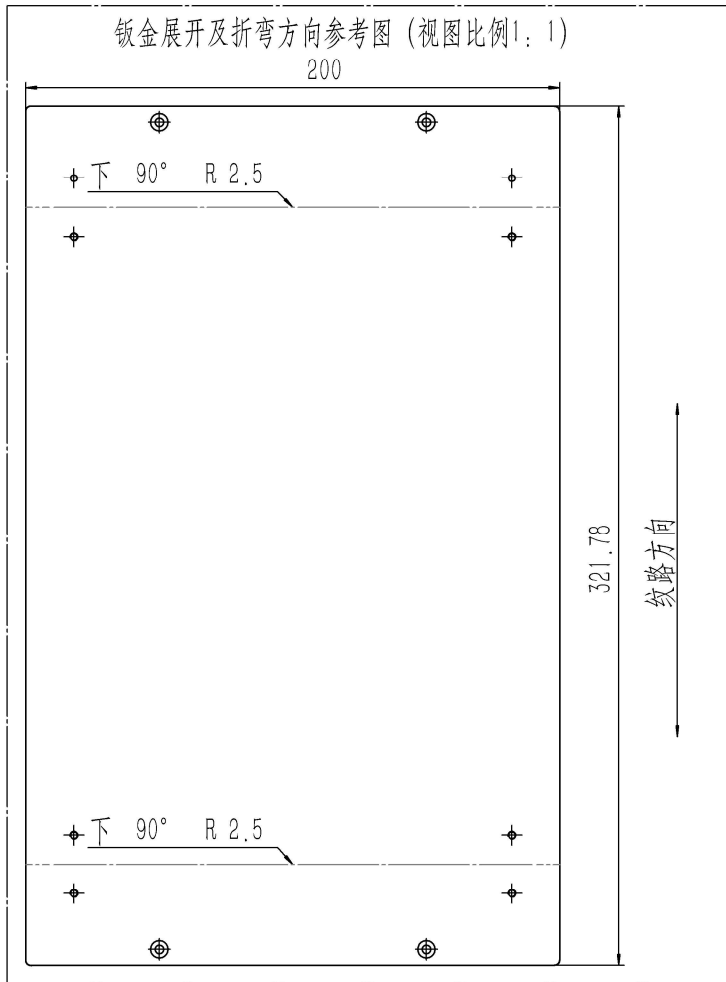

1
5 : 1

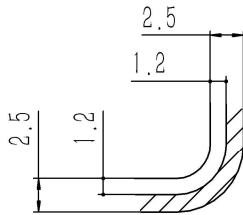

技术要求:

- 1、零件加工表面不应有划痕、擦伤等损伤零件表面的缺陷;
- 2、去除毛刺飞边,锐角倒钝;
- 3、未标注尺寸见3D数模。

业务代码: 250-80

A-A

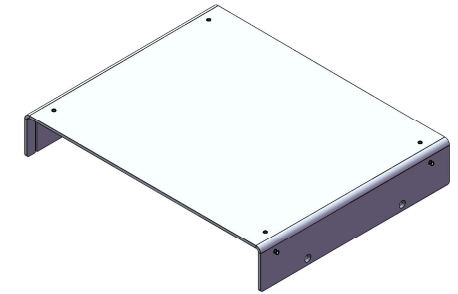
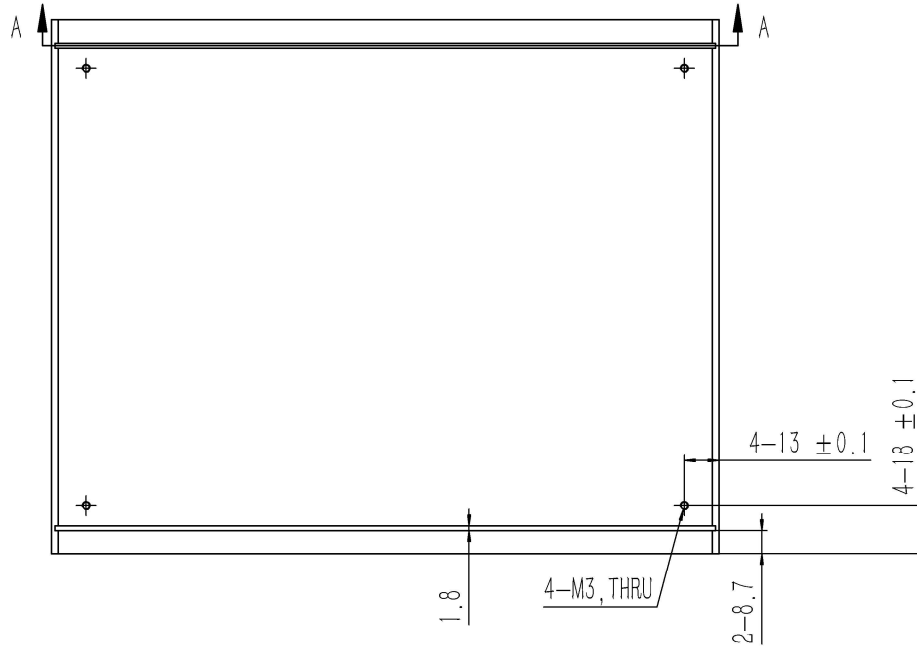
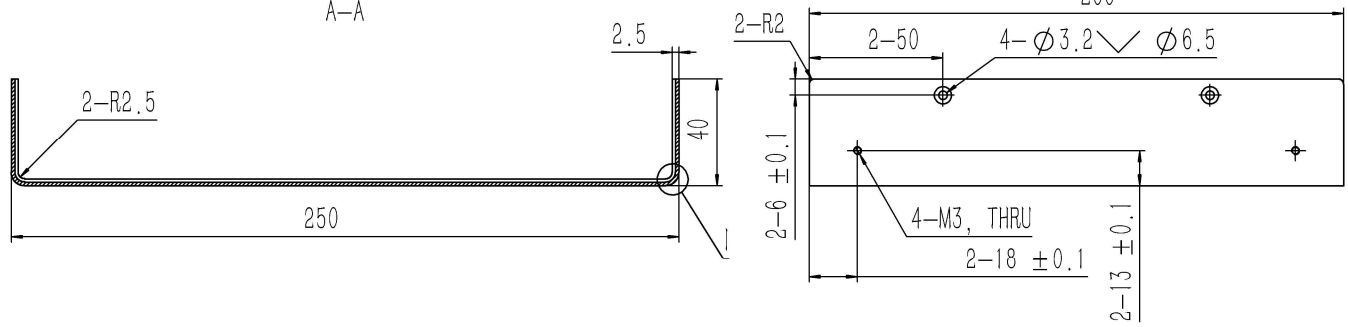

Tolerances (未注公差):	
0.5 to 6	± 0.1
6 to 30	± 0.2
30 to 120	± 0.3
120 to 400	± 0.4

Break sharp edges (未注锐边倒角): Ch 0.05 to 0.25 x45°	Angular tolerances (未注角度公差):
	<6° ± 10'
	<30° ± 20'
	<120° ± 30'
	>120° ± 1°
Position tolerances (未注位置公差):	± 0.05

Material (材料):	5052-H32	YONGU 永固
Weight: (重量) (Kg):	0.427	
Protection: (表面处理):		Drawing Number (图号):
Part Name (零/部件名称):	上下盖板	YG-S104-0000-002
Drawn by (绘图): 江瑞章	Date (日期): 2021.06.03	Size: (图幅): A1
Check by (校对):	Date (日期):	Scale (比例): 1:1
Signature by (批准):	Date (日期):	Revision (版本): A1
		Sheet (页数): 1 / 1

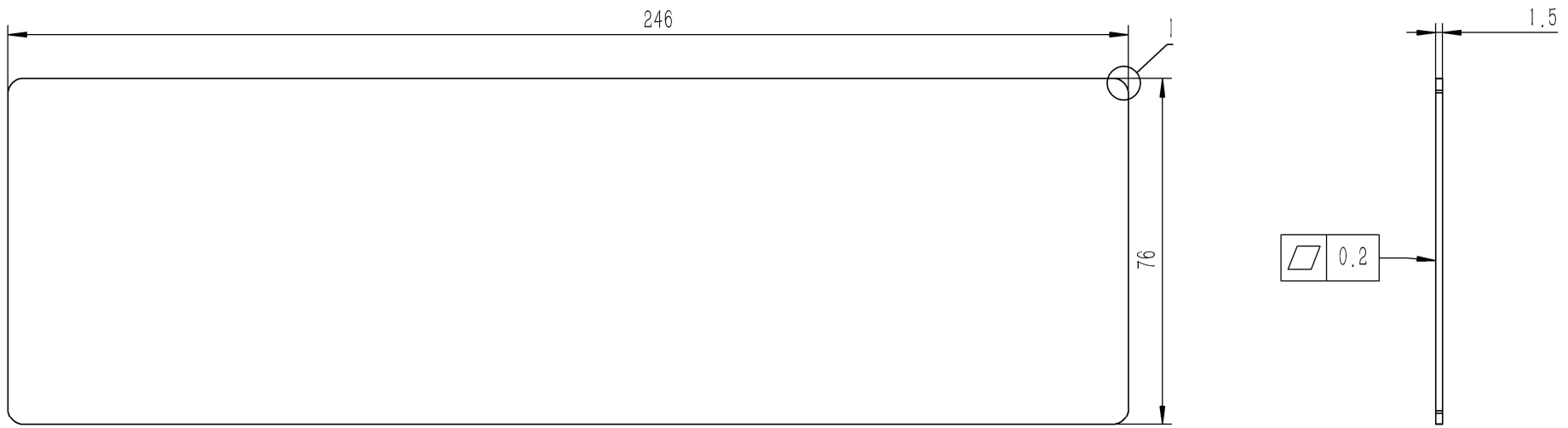

纹路方向

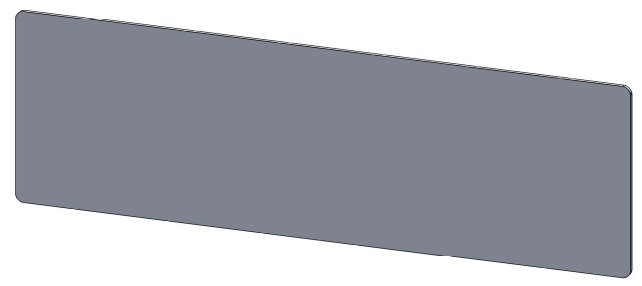
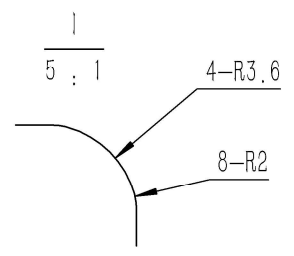

技术要求:
 1、零件加工表面不应有划痕、擦伤等损伤零件表面的缺陷;
 2、去除毛刺飞边,锐角倒钝;
 3、未标注尺寸见3D数模。

业务代码: 250-80

Tolerances (未注公差): 0.5 to 6 ± 0.1 6 to 30 ± 0.2 30 to 120 ± 0.3 120 to 400 ± 0.4	Material (材料):	5052-H32	YONGU 永固				
	Weight: (重量) (Kg)	0.075					
Break sharp edges (未注锐边倒角): Ch 0.05 to 0.25 x45°	Protection: (表面处理):		Drawing Number (图号): YG-S104-0000-003				
	Position tolerances (未注位置公差): ±0.05	Part Name (零/部件名称):		挡板			
Angular tolerances (未注角度公差): <6° ± 10' <30° ± 20' <120° ± 30' >120° ± 1°	Drawn by (绘图):	江瑞章	Date (日期):	2021.06.03	Size: (图幅):	A3	Sheet (页数): 1 / 1
	Check by (校对):		Date (日期):		Scale (比例):	1:1	
	Signature by (批准):		Date (日期):		Revision (版本):	A1	