

5	GB-T-70.1-2000-S-NL-M3X8	不锈钢内六角杯头螺丝M3X8	SUS 304	4	0.001	
4	GB-T-819.1-2000-C-BE-M3X6	碳钢发黑十字沉头螺丝M3X6	普通碳钢	4	0.0004	
3	YG-W04C-0000-003	后挡板	5052-H32	1	0.014	
2	YG-W04C-0000-002	前面板	5052-H32	1	0.086	
1	YG-W04C-0000-001	壳体	6063-T5	1	0.193	
序号	图号	名称	材料	数量	单重	备注

技术要求:

- 1、必须按照设计、工艺要求及本规定和有关标准进行装配;
- 2、所有零部件(包括外购、外协件)必须具有检验合格证方能进行装配;
- 3、零件在装配前必须清理和清洗干净,不得有毛刺、飞边、氧化皮、锈蚀、切屑、砂粒、灰尘和油污等,并应符合相应清洁度要求;
- 4、装配过程中零件不得磕碰、划伤和锈蚀;
- 5、油漆未干的零件不得进行装配;
- 6、相对运动的零件,装配时接触面间应加润滑油脂;
- 7、各零、部件装配后相对位置应准确。

Break sharp edges (未注锐边倒角): Ch 0.05 to 0.25 x45°	Angular tolerances (未注角度公差): <6° ± 10' <30° ± 20' <120° ± 30' >120° ± 1°
Position tolerances (未注位置公差): ±0.05	

Tolerances (未注公差): 0.5 to 6 ± 0.1 6 to 30 ± 0.2 30 to 120 ± 0.3 120 to 400 ± 0.4	Material (材料): (装配图)
	Weight: (重量) (Kg) 0.299
	Protection: (表面处理):
	Part Name (零/部件名称): W04C壳体
Drawn by (绘图): 邓展锋	Date (日期): 2020.05.16
Check by (校对):	Date (日期):
Signature by (批准):	Date (日期):

		Drawing Number (图号): YG-W04C-0000-000	
		Size (图幅): A3	Sheet (页数): 1 / 1
Scale (比例): 1:1		Revision (版本): A1	

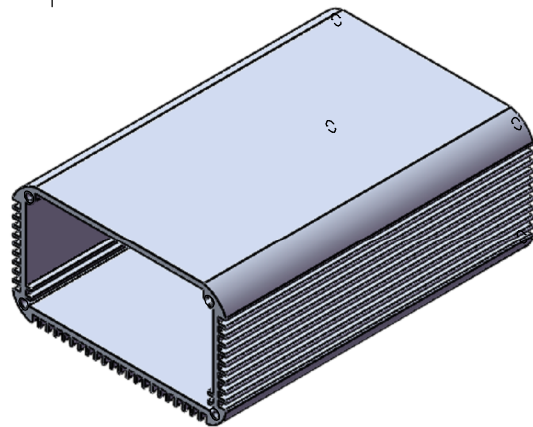
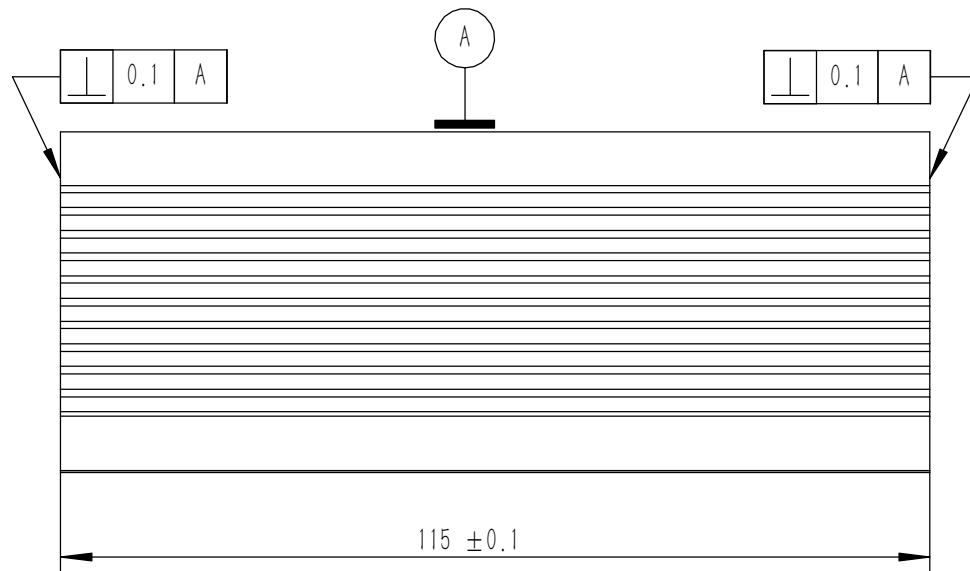
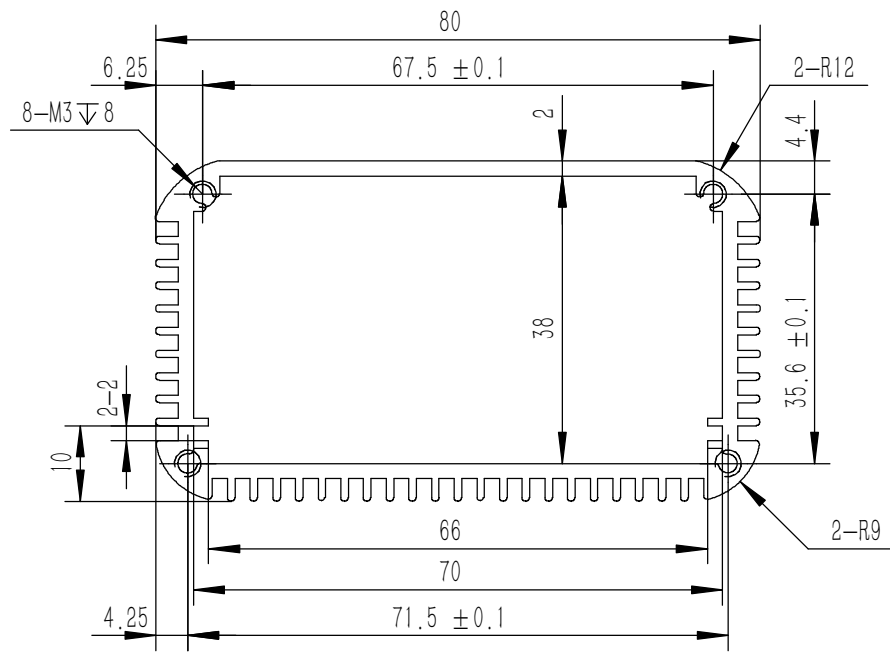

技术要求:

- 1、零件加工表面不应有划痕、擦伤等损伤零件表面的缺陷;
- 2、去除毛刺飞边, 锐角倒钝;
- 3、未标注尺寸见3D数模。

Tolerances (未注公差): 0.5 to 6 ± 0.1 6 to 30 ± 0.2 30 to 120 ± 0.3 120 to 400 ± 0.4	Material (材料):	6063-T5	
	Weight: (重量) (Kg)	0.193	
	Protection: (表面处理):		
	Part Name (零/部件名称):	壳体	
Break sharp edges (未注锐边倒角): Ch 0.05 to 0.25 x45°	Drawing Number (图号):		YG-W04C-0000-001
	Position tolerances (未注位置公差): ±0.05	Drawn by (绘图): 邓展锋	Date (日期): 2020.05.16
Angular tolerances (未注角度公差): <6° ± 10' <30° ± 20' <120° ± 30' >120° ± 1°		Check by (校对):	Date (日期):
	Signature by (批准):	Date (日期):	Scale (比例): 1:1
			Revision (版本): A1
			Sheet (页数): 1 / 1

**YONGU** 永固

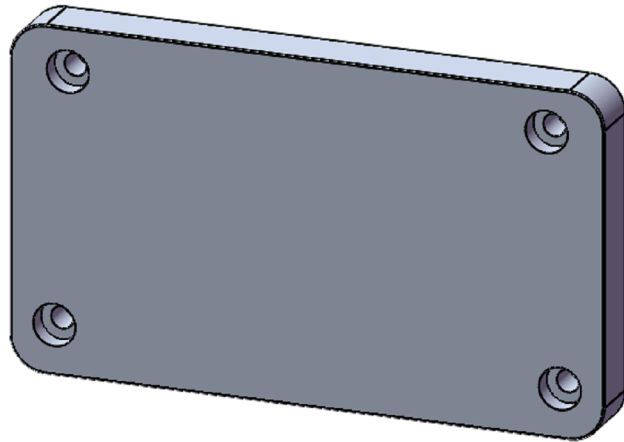
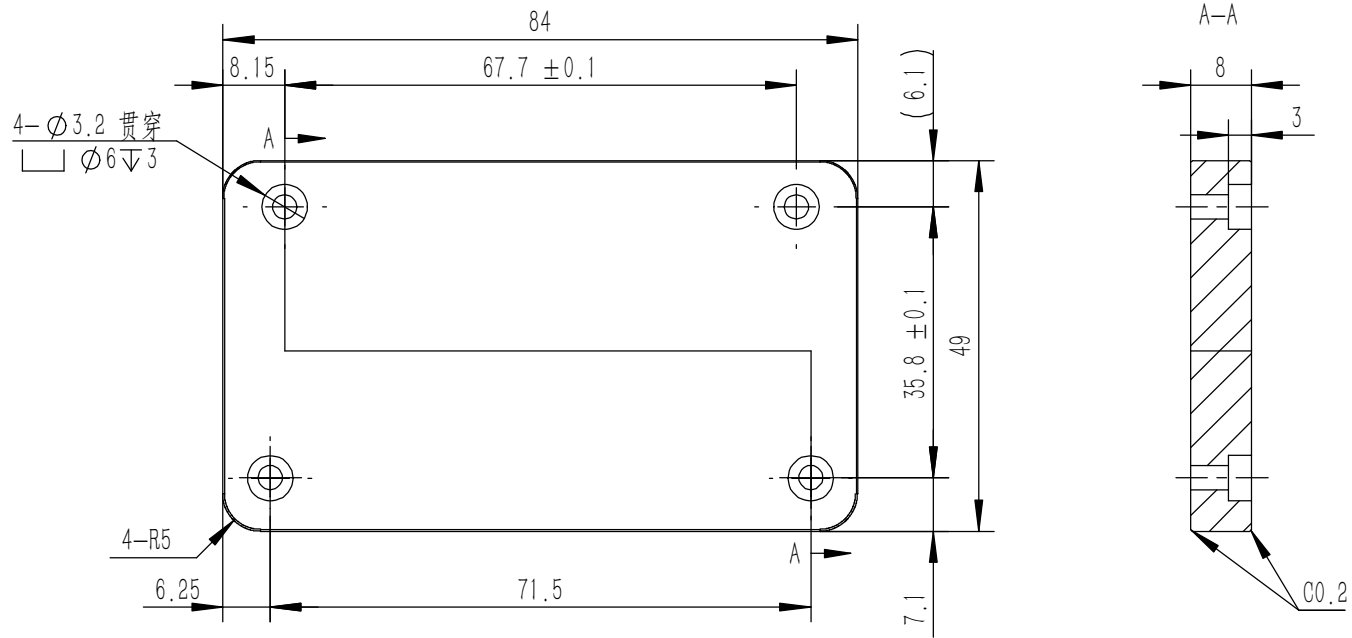

技术要求:

- 1、零件加工表面不应有划痕、擦伤等损伤零件表面的缺陷;
- 2、去除毛刺飞边, 锐角倒钝;
- 3、未标注尺寸见3D数模。

Tolerances (未注公差): 0.5 to 6 ± 0.1 6 to 30 ± 0.2 30 to 120 ± 0.3 120 to 400 ± 0.4	Material (材料):	5052-H32		<b>YONGU</b> 永固
	Weight: (重量) (Kg)	0.086		
Break sharp edges (未注锐边倒角): Ch 0.05 to 0.25 x45° Position tolerances (未注位置公差): ±0.05	Protection: (表面处理):			Drawing Number (图号): YG-W04C-0000-002
	Angular tolerances (未注角度公差): <6° ± 10' <30° ± 20' <120° ± 30' >120° ± 1°	Part Name (零/部件名称):	前面板	
	Part Name (零/部件名称):	前面板	Date (日期): 2020.05.16	Size: (图幅): A4
	Drawn by (绘图): 邓展锋	Date (日期): 2020.05.16	Scale (比例): 1:1	Sheet (页数):
	Check by (校对):	Date (日期):	Revision (版本): A1	1 / 1
	Signature by (批准):	Date (日期):		

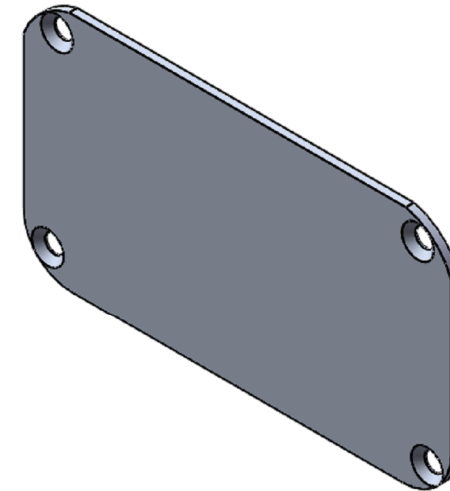
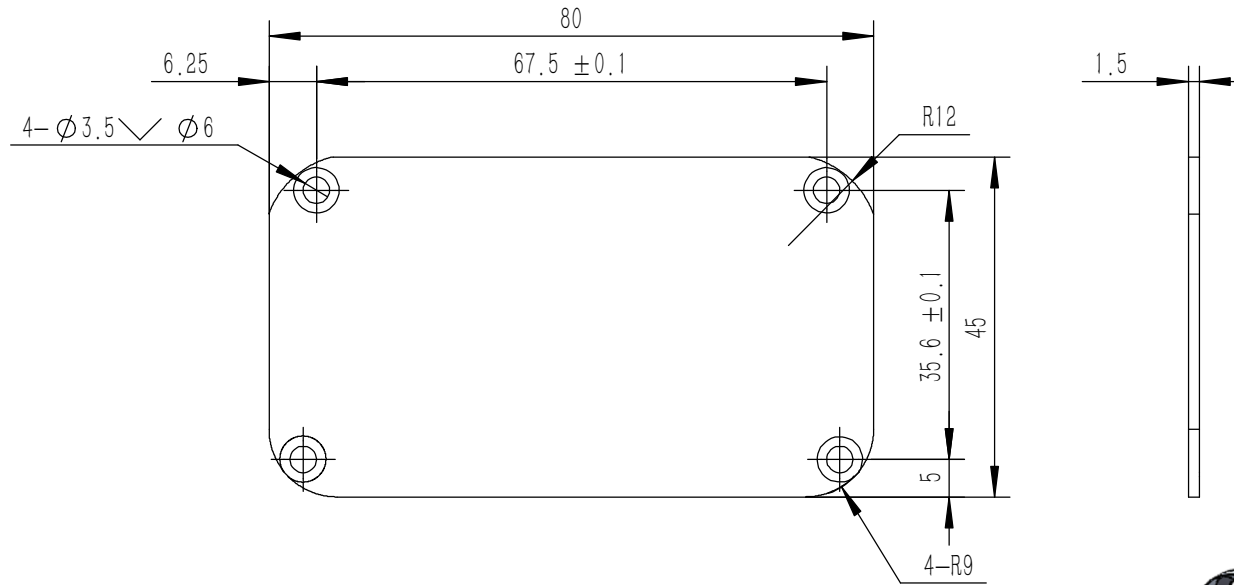

技术要求:

- 1、零件加工表面不应有划痕、擦伤等损伤零件表面的缺陷;
- 2、去除毛刺飞边, 锐角倒钝;
- 3、未标注尺寸见3D数模。

Tolerances (未注公差): 0.5 to 6 ± 0.1 6 to 30 ± 0.2 30 to 120 ± 0.3 120 to 400 ± 0.4	Material (材料):	5052-H32		<b>YONGU</b> 永固	
	Weight: (重量) (Kg)	0.014			
	Protection: (表面处理):				
	Part Name (零/部件名称):	后挡板		Drawing Number (图号): YG-W04C-0000-003	
Break sharp edges (未注锐边倒角): Ch 0.05 to 0.25 x45°	Angular tolerances (未注角度公差): <6° ± 10' <30° ± 20' <120° ± 30' >120° ± 1°	Drawn by (绘图): 邓展锋	Date (日期): 2020.05.16	Size: (图幅): A4	 Sheet (页数): 1 / 1
Position tolerances (未注位置公差): ±0.05	Check by (校对):	Date (日期):	Scale (比例): 1:1		
Signature by (批准):	Date (日期):	Revision (版本): A1			