

6	GB-T-70.1-2000-S-NL-M3X8	不锈钢内六角杯头螺丝M3X8	SUS 304	8	0.001	
5	YG-TY-XJD-006	自粘橡胶垫12X28.9X1	硅橡胶	4	0.000	
4	YG-L10A-0000-004	点胶密封圈	复合发泡胶	2	0.010	
3	YG-L10A-0000-003	下盖	5052-H32	1	0.511	
2	YG-L10A-0000-001	壳体	6063-T5	1	0.166	
1	YG-L10A-0000-002	上盖	5052-H32	1	0.478	

- 技术要求:
- 1、必须按照设计、工艺要求及本规定和有关标准进行装配;
 - 2、所有零部件(包括外购、外协件)必须具有检验合格证方能进行装配;
 - 3、零件在装配前必须清理和清洗干净,不得有毛刺、飞边、氧化皮、锈蚀、切屑、砂粒、灰尘和油污等,并应符合相应清洁度要求;
 - 4、装配过程中零件不得磕碰、划伤和锈蚀;
 - 5、油漆未干的零件不得进行装配;
 - 6、相对运动的零件,装配时接触面间应加润滑油脂;
 - 7、各零、部件装配后相对位置应准确。

序号 (Item)	图号 (Drawing Number)	名称 (Part Name)	材料 (Material)	数量 (QTY)	单重 (Weight)	备注 (Note)
Tolerances (未注公差):		Material (材料): (装配图)				
0.5 to 6 ± 0.1		Weight: (重量) (Kg): 1.184				
6 to 30 ± 0.2		Protection: (表面处理):		Drawing Number (图号):		
30 to 120 ± 0.3		Part Name (零/部件名称):		YG-L10A-0000-000		
120 to 400 ± 0.4		L10A防水壳体		Size: (图幅): A2		
Break sharp edges (未注锐边倒角): Ch 0.05 to 0.25 x45°		Angular tolerances (未注角度公差):		Drawn by (绘图): 许宏彬		Date (日期): 2020.10.30
Position tolerances (未注位置公差): ±0.05		<6° ± 10'		Check by (校对):		Date (日期):
		<30° ± 20'		Signature by (批准):		Date (日期):
		<120° ± 30'		Scale (比例): 1:1		Sheet (页数):
		>120° ± 1°		Revision (版本): A1		1 / 1

业务代码:

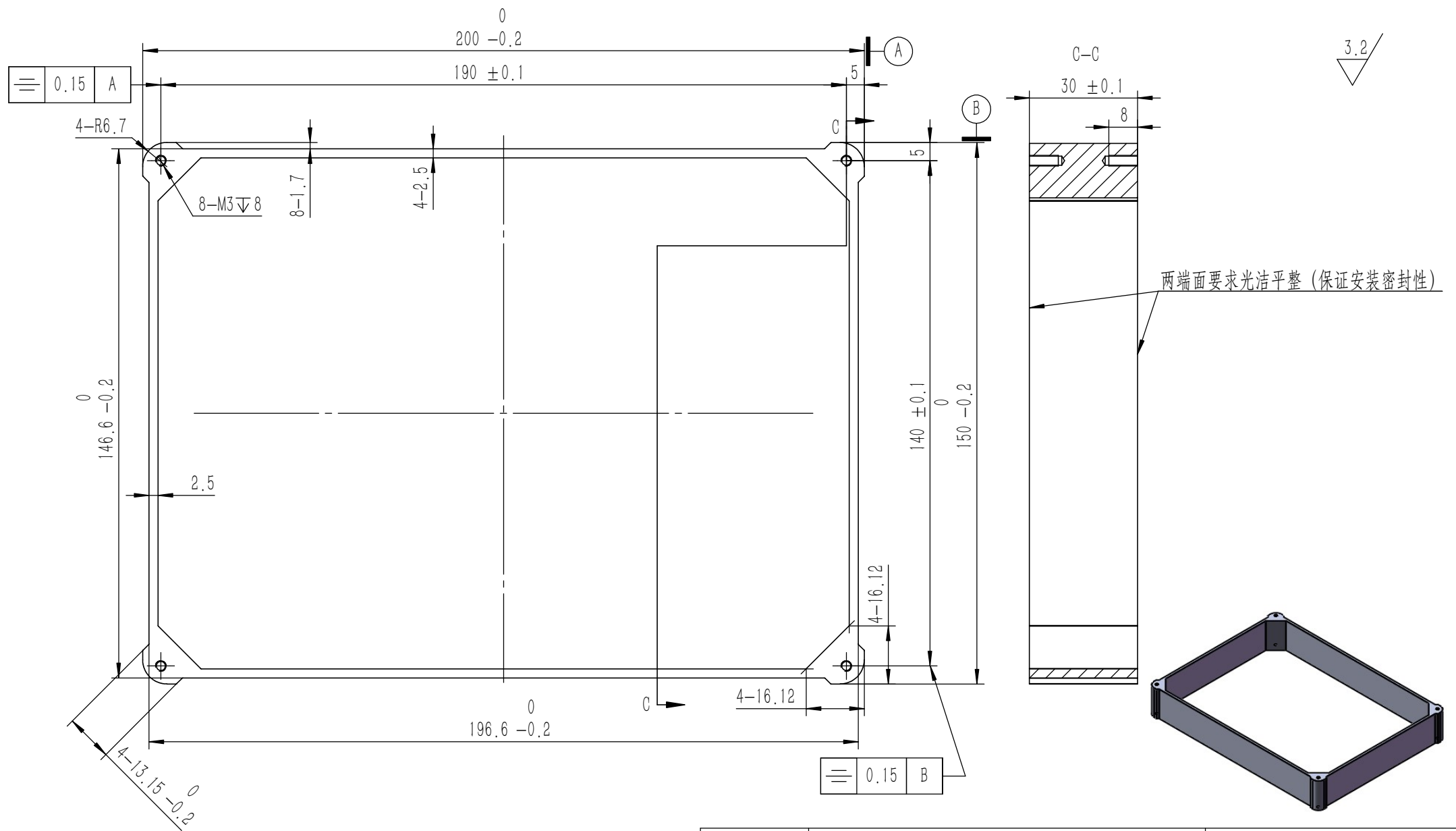

技术要求:

- 1、零件加工表面不应有划痕、擦伤等损伤零件表面的缺陷;
- 2、去除毛刺飞边, 锐角倒钝;
- 3、未标注尺寸见3D数模。

业务代码:

Break sharp edges (未注锐边倒角): Ch 0.05 to 0.25 x45°	Angular tolerances (未注角度公差): <6° ± 10' <30° ± 20' <120° ± 30' >120° ± 1°
Position tolerances (未注位置公差): ±0.05	

Tolerances (未注公差): 0.5 to 6 ± 0.1 6 to 30 ± 0.2 30 to 120 ± 0.3 120 to 400 ± 0.4	Material (材料): 6063-T5	YONGU 永固
Weight: (重量) (Kg) 0.166	Protection: (表面处理):	
Part Name (零/部件名称): 壳体	Part Name (零/部件名称):	Drawing Number (图号): YG-L10A-0000-001
Drawn by (绘图): 许宏彬	Date (日期): 2021.01.30	Size: (图幅): A3
Check by (校对):	Date (日期):	Scale (比例): 1:1
Signature by (批准):	Date (日期):	Revision (版本): A1
		Sheet (页数): 1 / 1

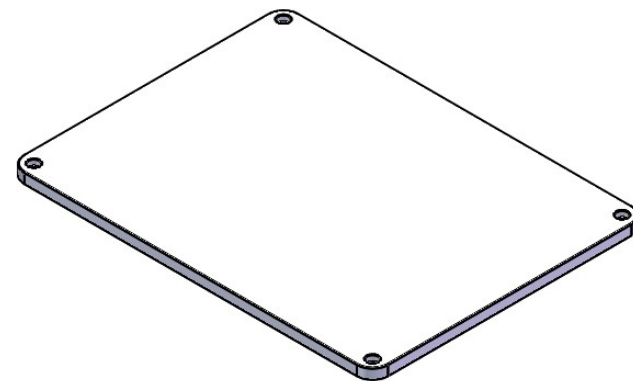
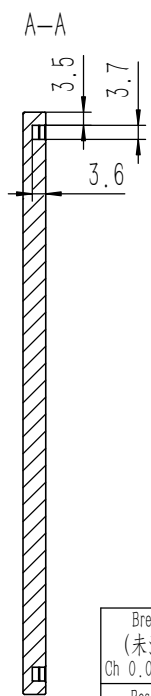
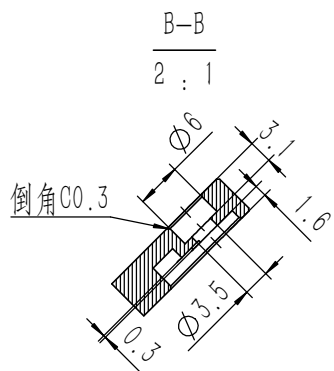
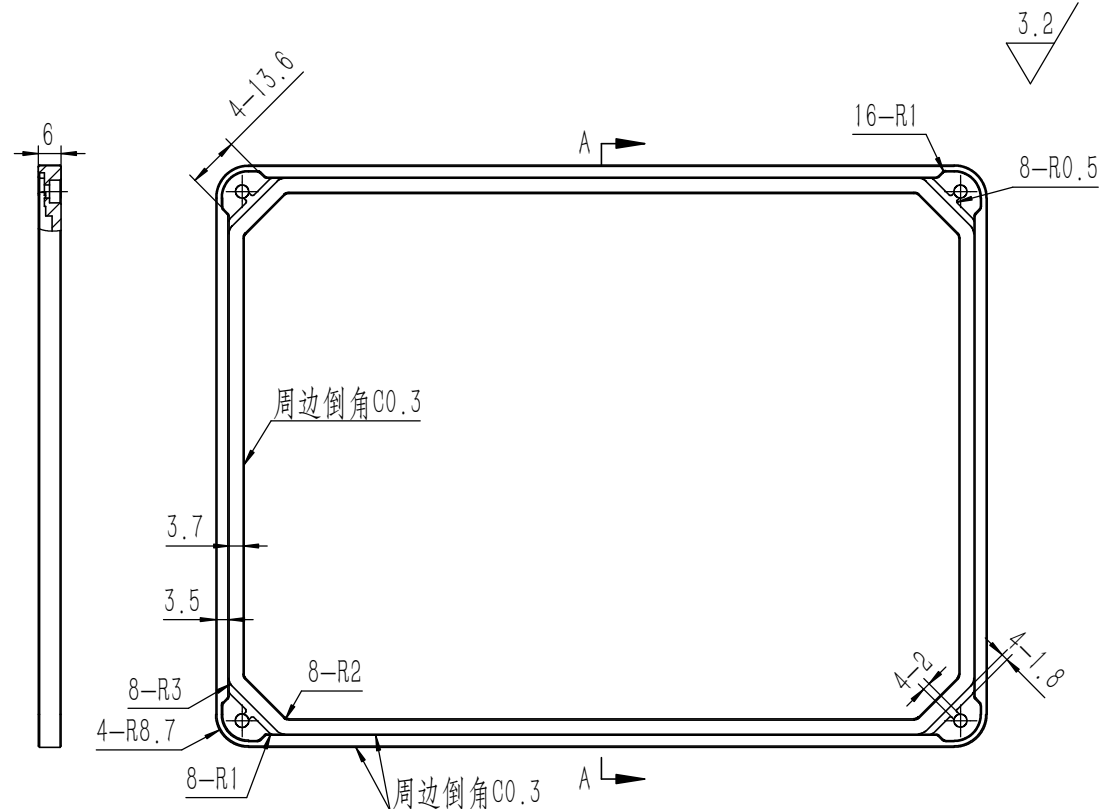
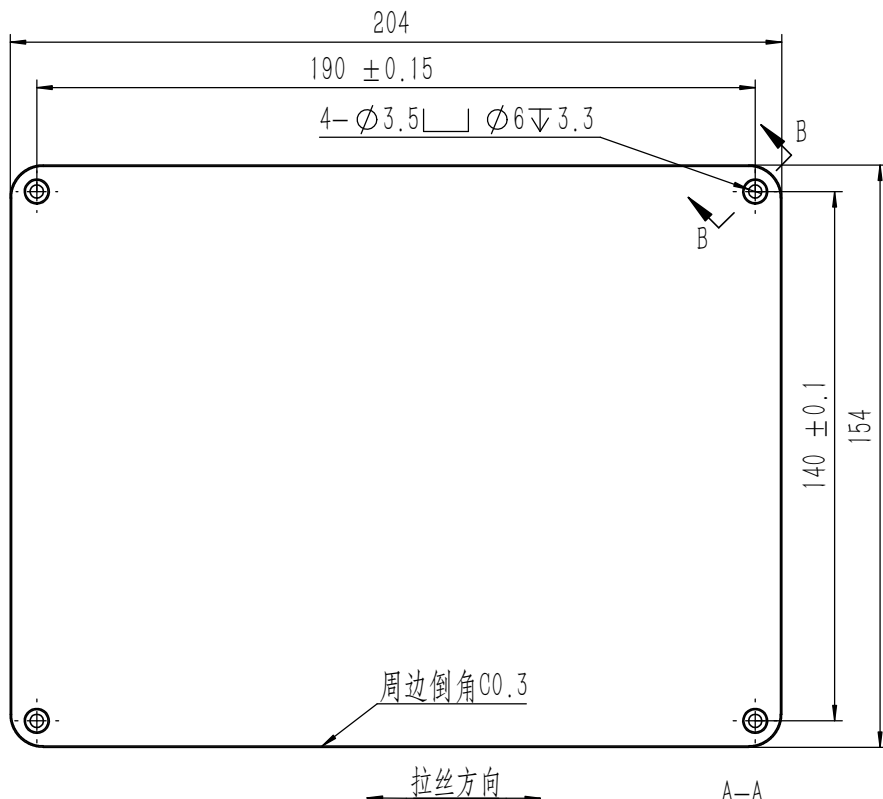

技术要求:

- 1、零件加工表面不应有划痕、擦伤等损伤零件表面的缺陷;
- 2、去除毛刺飞边, 锐角倒钝;
- 3、未标注尺寸见3D数模;
- 4、靠近防水槽外边打防水胶, 防水胶宽度3.7mm高度3.6±0.2mm。

业务代码:

Break sharp edges (未注锐边倒角): Ch 0.05 to 0.25 x45°	Angular tolerances (未注角度公差): <6° ± 10' <30° ± 20' <120° ± 30' >120° ± 1°
Position tolerances (未注位置公差): ±0.05	

Tolerances (未注公差): 0.5 to 6 ± 0.1 6 to 30 ± 0.2 30 to 120 ± 0.3 120 to 400 ± 0.4	Material (材料): 5052-H32	YONGU			
	Weight: (重量) (Kg): 0.478				
	Protection: (表面处理):	Drawing Number (图号): YG-L10A-0000-002			
	Part Name (零/部件名称): 上盖				
	Drawn by (绘图): 许宏彬	Date (日期): 2021.04.22	Size: (图幅): A2		
	Check by (校对):	Date (日期):	Scale (比例): 1:1		Sheet (页数): 1 / 1
	Signature by (批准):	Date (日期):	Revision (版本): A1		

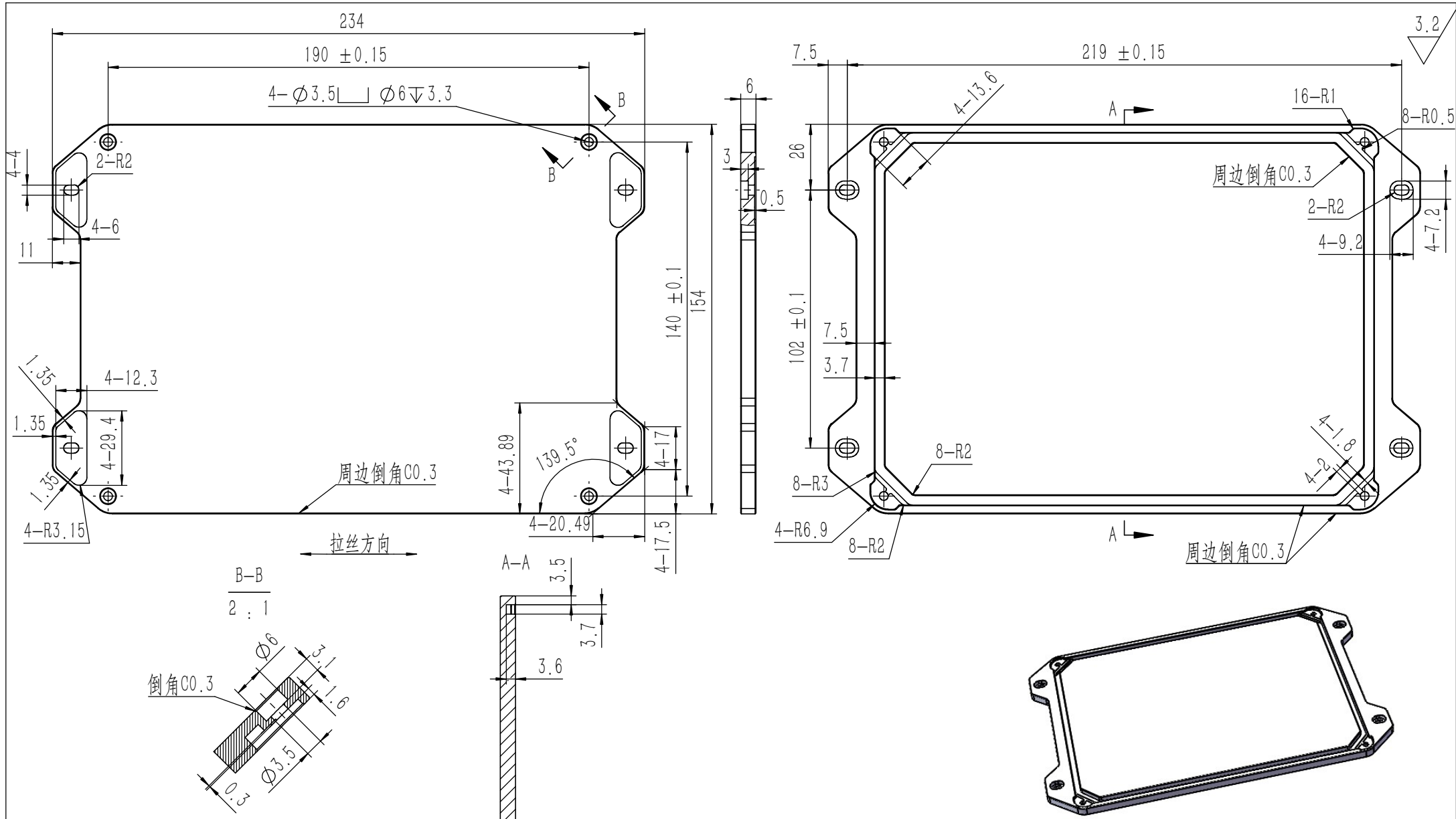

- 技术要求:
- 1、零件加工表面不应有划痕、擦伤等损伤零件表面的缺陷;
 - 2、去除毛刺飞边,锐角倒钝;
 - 3、未标注尺寸见3D数模;
 - 4、靠近防水槽外边打防水胶,防水胶宽度3.7mm高度3.6±0.2mm。

业务代码:

Break sharp edges (未注锐边倒角): Ch 0.05 to 0.25 x45°	Angular tolerances (未注角度公差): <6° ± 10' <30° ± 20' <120° ± 30' >120° ± 1°
Position tolerances (未注位置公差): ±0.05	

Tolerances (未注公差): 0.5 to 6 ± 0.1 6 to 30 ± 0.2 30 to 120 ± 0.3 120 to 400 ± 0.4	Material (材料): 5052-H32	
	Weight: (重量) (Kg): 0.511	
Protection: (表面处理):	Part Name (零/部件名称): 下盖	Drawing Number (图号): YG-L10A-0000-003
Drawn by (绘图): 许宏彬	Date (日期): 2021.04.22	Size (图幅): A2
Check by (校对):	Date (日期):	Scale (比例): 1:1
Signature by (批准):	Date (日期):	Revision (版本): A1
		Sheet (页数): 1 / 1