

技术要求:

- 1、必须按照设计、工艺要求及本规定和有关标准进行装配;
- 2、所有零部件(包括外购、外协件)必须具有检验合格证方能进行装配;
- 3、零件在装配前必须清理和清洗干净,不得有毛刺、飞边、氧化皮、锈蚀、切屑、砂粒、灰尘和油污等,并应符合相应清洁度要求;
- 4、装配过程中零件不得磕碰、划伤和锈蚀;
- 5、油漆未干的零件不得进行装配;
- 6、相对运动的零件,装配时接触面间应加润滑油脂;
- 7、各零、部件装配后相对位置应准确。

业务代码:

Break sharp edges (未注锐边倒角): Ch 0.05 to 0.25 x45°	Angular tolerances (未注角度公差): <6° ± 10' <30° ± 20' <120° ± 30' >120° ± 1°
Position tolerances (未注位置公差): ±0.05	

4	GB-T-70.1-2000-S-NL-M3X8	不锈钢内六角杯头螺丝M3X8	SUS 304	8	0.001	
3	YG-K20C01-0000-002	K20C红色塑料端盖	ABS	2	0.021	
2	YG-K20C-0000-003	挡板	5052-H32	2	0.032	
1	YG-K20C-0000-001	壳体	6063-T5	2	0.102	
序号 (Item)	图号 (Drawing Number)	名称 (Part Name)	材料 (Material)	数量 (QTY)	单重 (Weight)	备注 (Note)

Tolerances (未注公差): 0.5 to 6 ± 0.1 6 to 30 ± 0.2 30 to 120 ± 0.3 120 to 400 ± 0.4		Material (材料): (装配图)		<b>YONGU</b> 永固		
		Weight: (重量) (Kg): 0.317				
		Protection: (表面处理):		Drawing Number (图号):		
		Part Name (零/部件名称):		YG-K20C-0000-000		
		K20C壳体				
Drawn by (绘图): 江瑞章		Date (日期): 2020.12.14		Size (图幅): A2		Sheet (页数): 1 / 1
Check by (校对):		Date (日期):		Scale (比例): 1:1		
Signature by (批准):		Date (日期):		Revision (版本): A1		

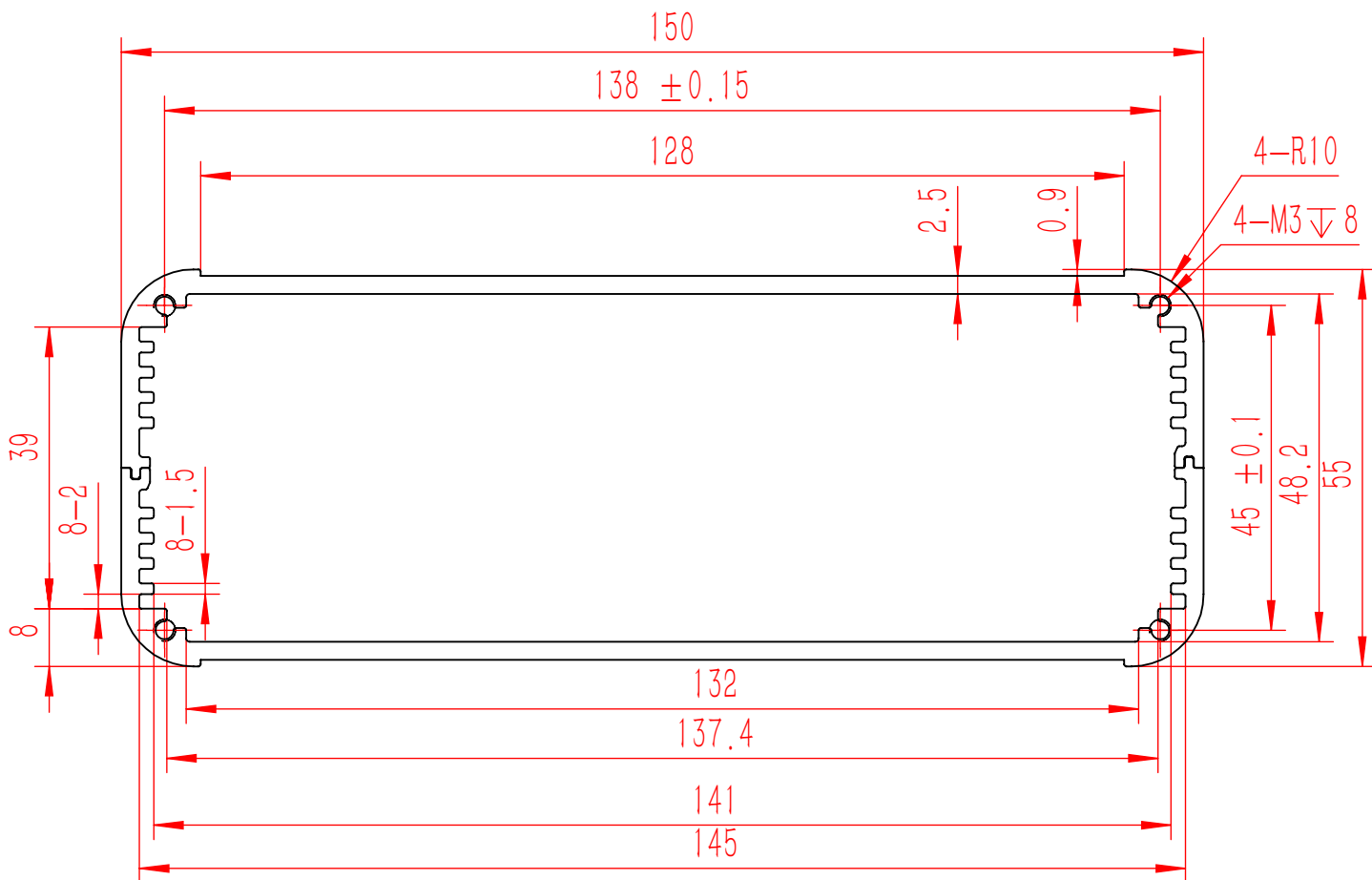

Tolerances (未注公差): 0.5 to 6 ± 0.1 6 to 30 ± 0.2 30 to 120 ± 0.3 120 to 400 ± 0.4		Material (材料): (装配图) Weight: (重量) (Kg) 0.466 Protection: (表面处理): Part Name (零/部件名称): YG-K20截面图		<b>YONGU</b> 永固	
Break sharp edges (未注锐边倒角): Ch 0.05 to 0.25 x45°		Angular tolerances (未注角度公差): <6° ± 10' <30° ± 20' <120° ± 30' >120° ± 1°		Drawing Number (图号): YG-K20-JMT	
Position tolerances (未注位置公差): ±0.05		Drawn by (绘图): 江瑞章 Date (日期): 2020.12.14		Size: (图幅): A4 Scale (比例): 1:1 Sheet (页数): 1 / 1	
		Check by (校对): Date (日期):		Revision (版本): A1	
		Signature by (批准): Date (日期):			

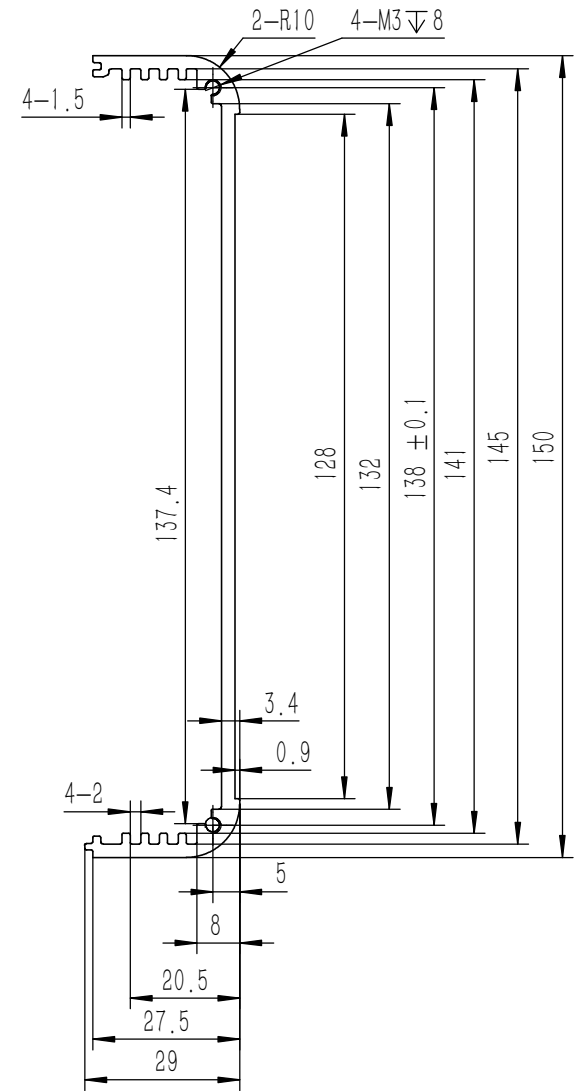
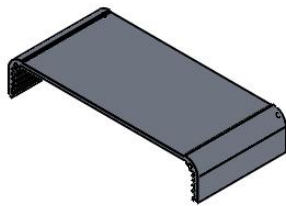
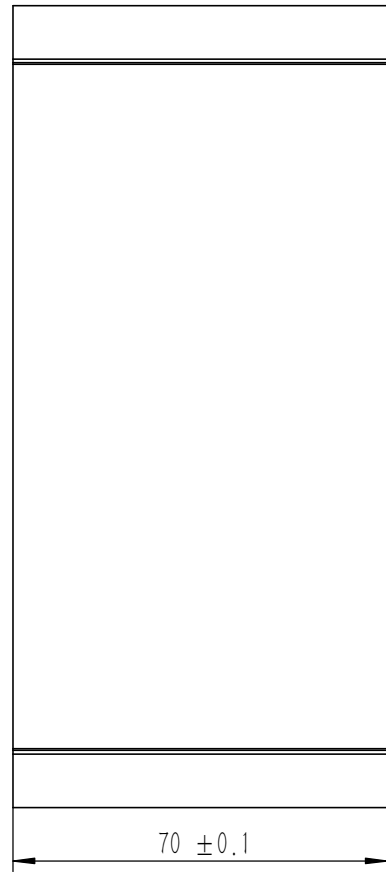

技术要求:

- 1、未注倒角R0.3
- 2、零件加工表面不应有划痕、擦伤等损伤零件表面的缺陷;
- 3、去除毛刺飞边,锐角倒钝;
- 4、未标注尺寸见3D数模。

业务代码:

Break sharp edges (未注锐边倒角): Ch 0.05 to 0.25 x45°	Angular tolerances (未注角度公差): <6° ± 10' <30° ± 20' <120° ± 30' >120° ± 1°
Position tolerances (未注位置公差): ±0.05	

Tolerances (未注公差): 0.5 to 6 ± 0.1 6 to 30 ± 0.2 30 to 120 ± 0.3 120 to 400 ± 0.4	Material (材料): 6063-T5	YONGU 永固
	Weight: (重量) (Kg) 0.102	
	Protection: (表面处理):	
	Part Name (零/部件名称): 壳体	Drawing Number (图号): YG-K20C-0000-001
	Drawn by (绘图): 江瑞章	Date (日期): 2020.12.14
	Check by (校对):	Date (日期):
	Signature by (批准):	Date (日期):
		Size: (图幅): A3
		Scale (比例): 1:1
		Revision (版本): A1
		Sheet (页数): 1 / 1

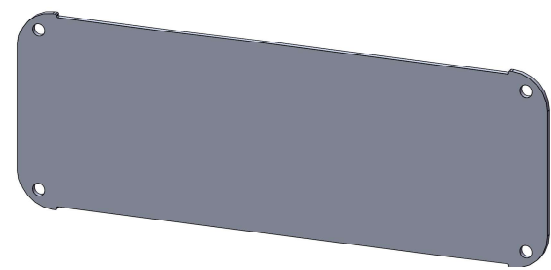
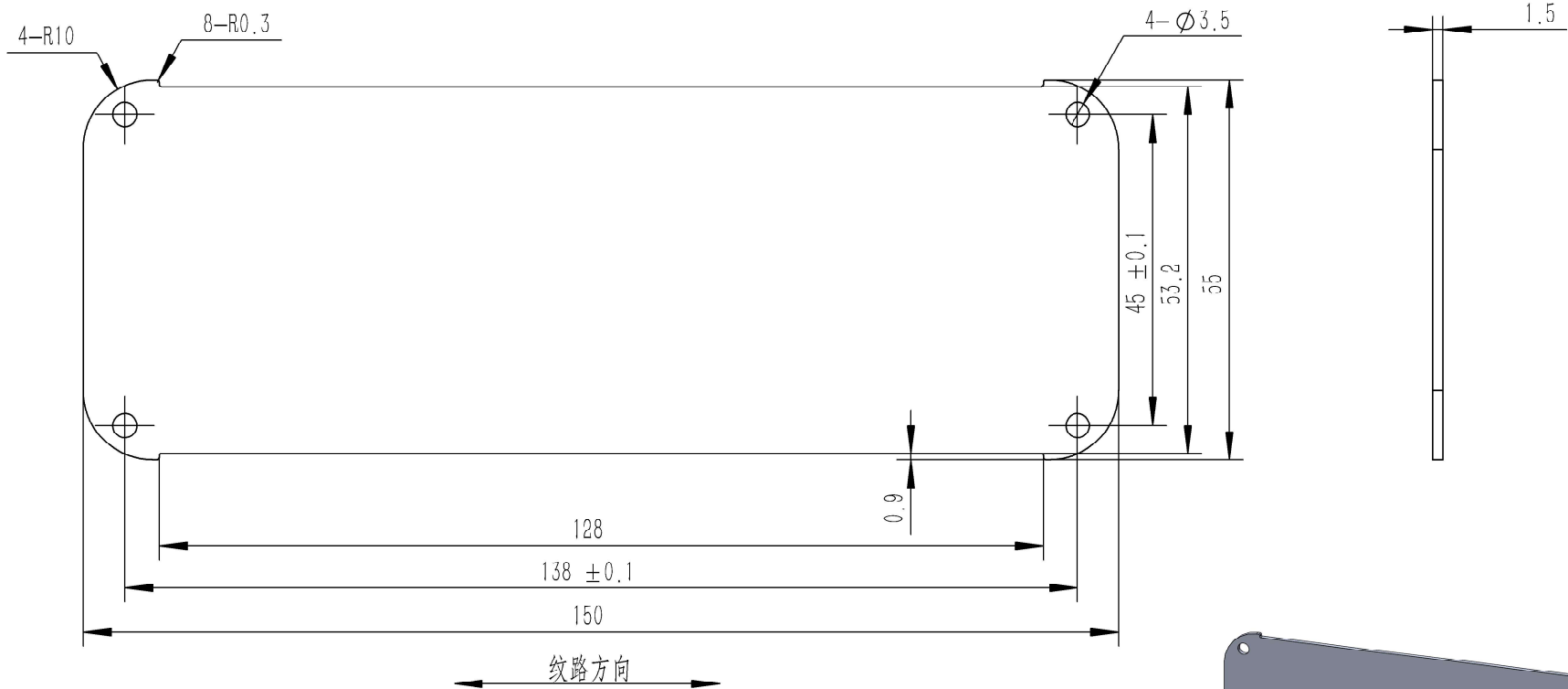

技术要求:

- 1、零件加工表面不应有划痕、擦伤等损伤零件表面的缺陷;
- 2、去除毛刺飞边, 锐角倒钝;
- 3、未标注尺寸见3D数模。

业务代码:

Break sharp edges (未注锐边倒角): Ch 0.05 to 0.25 x45°	Angular tolerances (未注角度公差): <6° ± 10' <30° ± 20' <120° ± 30' >120° ± 1°	Tolerances (未注公差):	Material (材料):	5052-H32	<b>YONGU</b> 永固
		0.5 to 6 ± 0.1 6 to 30 ± 0.2 30 to 120 ± 0.3 120 to 400 ± 0.4	Weight: (重量) (Kg)	0.032	
Position tolerances (未注位置公差): ±0.05		Protection: (表面处理):	Part Name (零/部件名称):		Drawing Number (图号):
			挡板		YG-K20C-0000-003
		Drawn by (绘图): 江瑞章	Date (日期): 2020.12.14	Size: (图幅): A4	Sheet (页数):
		Check by (校对):	Date (日期):	Scale (比例): 1:1	
		Signature by (批准):	Date (日期):	Revision (版本): A1	1 / 1

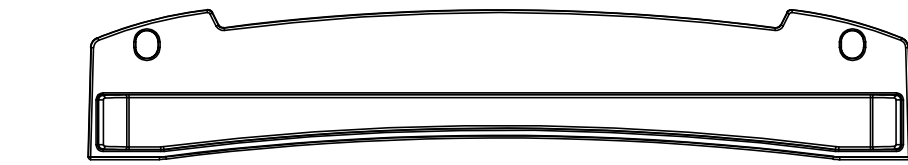

A

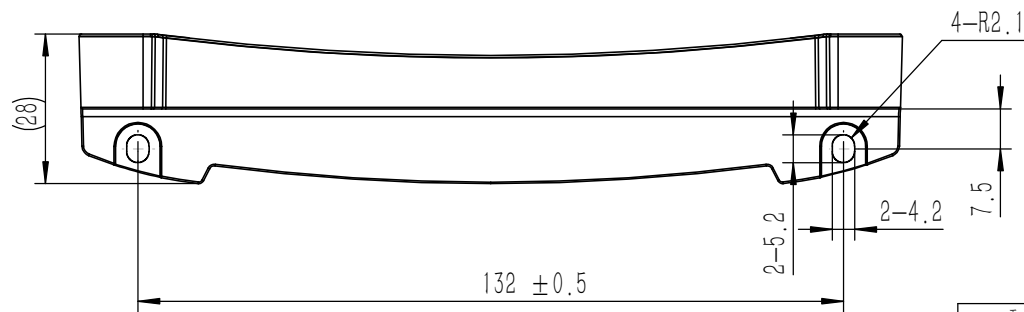
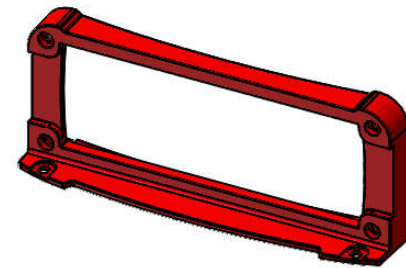
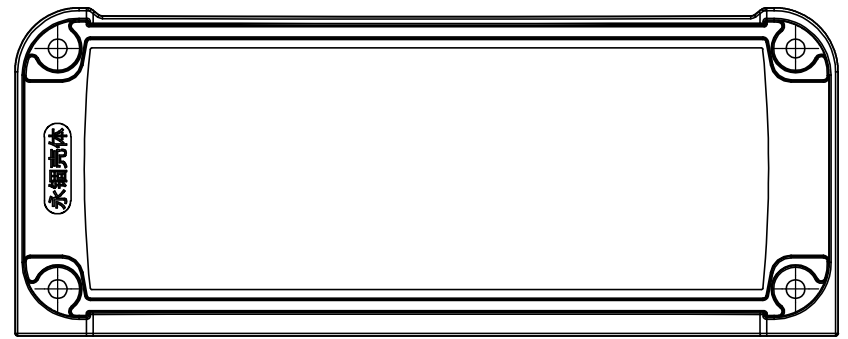
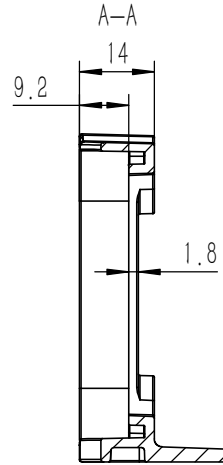
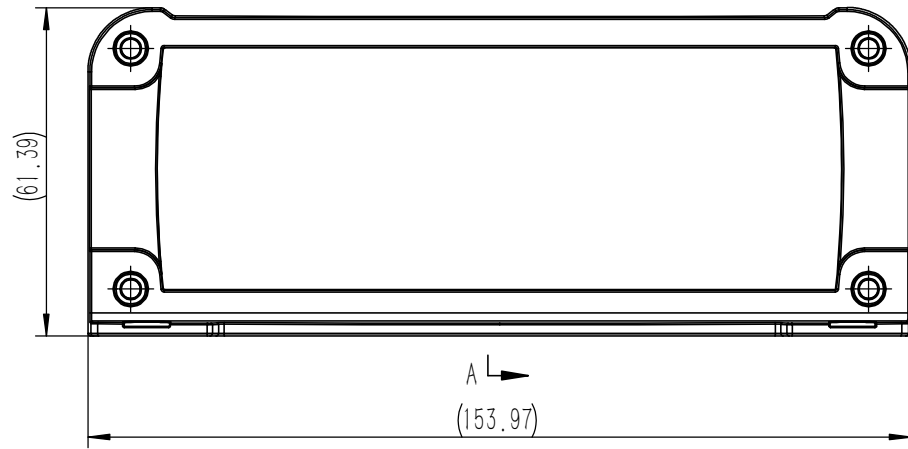

技术要求:  
 1、零件表面不允许有收缩、凹陷、熔接痕、水纹、顶白及飞边等缺陷  
 2、未标注尺寸见3D数模。

业务代码:

Break sharp edges (未注锐边倒角): Ch 0.05 to 0.25 x45°	Angular tolerances (未注角度公差): <6° ± 10' <30° ± 20' <120° ± 30' >120° ± 1°
Position tolerances (未注位置公差): ±0.05	

Tolerances (未注公差): 0.5 to 6 ± 0.1 6 to 30 ± 0.2 30 to 120 ± 0.3 120 to 400 ± 0.4	Material (材料): ABS	YONGU 永固
	Weight: (重量) (Kg) 0.021	
	Protection: (表面处理): 喷橡胶漆	
	Part Name (零/部件名称): K20C红色塑料端盖	Drawing Number (图号): YG-K20C01-0000-002
	Drawn by (绘图): 江瑞章	Date (日期): 2020.12.14
	Check by (校对):	Date (日期):
	Signature by (批准):	Date (日期):
		Size (图幅): A3
		Scale (比例): 1:1
		Revision (版本): A1
		Sheet (页数): 1 / 1