

技术要求:

- 1、必须按照设计、工艺要求及本规定和有关标准进行装配;
- 2、所有零部件(包括外购、外协件)必须具有检验合格证方能进行装配;
- 3、零件在装配前必须清理和清洗干净,不得有毛刺、飞边、氧化皮、锈蚀、切屑、砂粒、灰尘和油污等,并应符合相应清洁度要求;
- 4、装配过程中零件不得磕碰、划伤和锈蚀;
- 5、油漆未干的零件不得进行装配;
- 6、相对运动的零件,装配时接触面间应加润滑油脂;
- 7、各零、部件装配后相对位置应准确。

业务代码:

6	YG-MH03-0000-004	MH03压铸端盖	ADC12	2	0.05	
5	YG-MH03-0000-003	装饰条	6063-T5	2	0.00	
4	YG-MH03-0000-002	下壳体	6063-T5	1	0.13	
3	YG-MH03-0000-001	上壳体	6063-T5	1	0.07	
2	YG-MH-MFGJQ-003	MH03红色密封圈	硅胶	2	0.00	
1	GB-T-70.1-2000-S-NL-M3X8	不锈钢内六角杯头螺丝M3X8	SUS 304	4	0.001	

序号 (Item)	图号 (Drawing Number)	名称 (Part Name)	材料 (Material)	数量 (QTY)	单重 (Weight)	备注 (Note)
Tolerances (未注公差):		Material (材料): (装配图)				
0.5 to 6 ± 0.1		Weight: (重量) (Kg) 0.33				
6 to 30 ± 0.2		Protection: (表面处理):		Drawing Number (图号):		
30 to 120 ± 0.3		Part Name (零/部件名称):		YG-MH03-0000-000		
120 to 400 ± 0.4		MH03壳体		Scale (图幅): A4		
Break sharp edges (未注锐边倒角): Ch 0.05 to 0.25 x45°		Angular tolerances (未注角度公差):		Date (日期): 2023.12.23		
<6° ± 10'		<30° ± 20'		Signature by (绘图): 杨志业		
Position tolerances (未注位置公差): ±0.05		<120° ± 30'		Date (日期):		
		>120° ± 1°		Signature by (校对):		
				Date (日期):		
				Signature by (批准):		
				Date (日期):		
				Revision (版本): A1		
				Sheet (页数): 1 / 1		

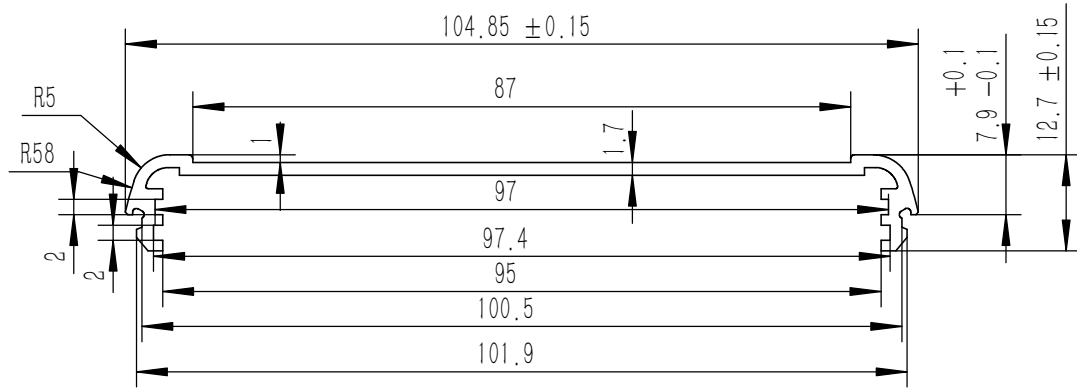

技术要求:

- 1、零件加工表面不应有划痕、擦伤等损伤零件表面的缺陷;
- 2、去除毛刺飞边,锐角倒钝;
- 3、未标注尺寸见3D数模。

业务代码:

Break sharp edges (未注锐边倒角): Ch 0.05 to 0.25 x45°	Angular tolerances (未注角度公差): <6° ± 10' <30° ± 20' <120° ± 30' >120° ± 1°
Position tolerances (未注位置公差): ±0.05	

Tolerances (未注公差): 0.5 to 6 ± 0.1 6 to 30 ± 0.2 30 to 120 ± 0.3 120 to 400 ± 0.4	Material (材料): 6063-T5	YONGU 永固
	Weight: (重量) (Kg) 0.07	
	Protection: (表面处理):	
	Part Name (零/部件名称): 上壳体	Drawing Number (图号): YG-MH03-0000-001
	Drawn by (绘图): 杨志业	Date (日期): 2023.12.23
	Check by (校对):	Date (日期):
	Signature by (批准):	Date (日期):
	Size: (图幅): A4	Scale (比例): 1:1
	Revision (版本): A1	Sheet (页数): 1 / 1

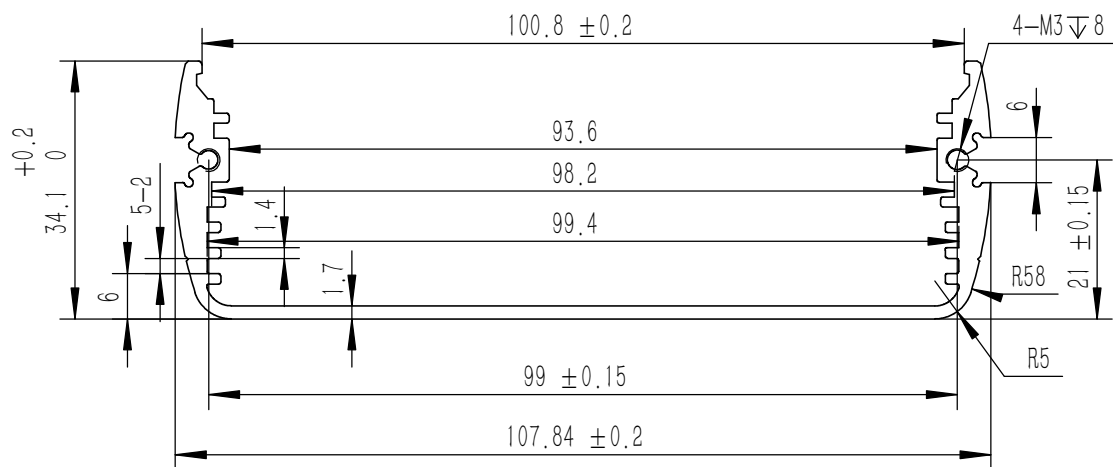

0.1 A

0.1 A

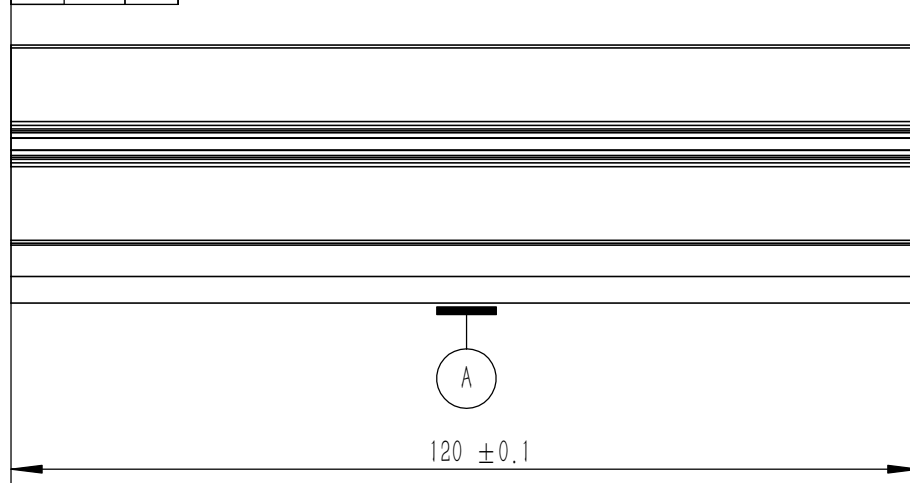

技术要求:

- 1、零件加工表面不应有划痕、擦伤等损伤零件表面的缺陷;
- 2、去除毛刺飞边, 锐角倒钝;
- 3、未标注尺寸见3D数模。

业务代码:

Tolerances (未注公差): 0.5 to 6 ± 0.1 6 to 30 ± 0.2 30 to 120 ± 0.3 120 to 400 ± 0.4	Material (材料):	6063-T5	YONGU 永固
	Weight: (重量) (Kg)	0.13	
Break sharp edges (未注锐边倒角): Ch 0.05 to 0.25 x45°	Protection: (表面处理):		Drawing Number (图号): YG-MH03-0000-002
	Position tolerances (未注位置公差): ±0.05	Part Name (零/部件名称): 下壳体	
Angular tolerances (未注角度公差): <6° ± 10' <30° ± 20' <120° ± 30' >120° ± 1°	Drawn by (绘图): 杨志业	Date (日期): 2023.12.23	Size: (图幅): A4
	Check by (校对):	Date (日期):	Scale (比例): 1:1
	Signature by (批准):	Date (日期):	Revision (版本): A1
			Sheet (页数): 1 / 1

1
5 : 1

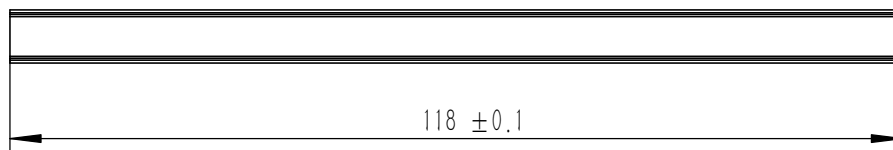
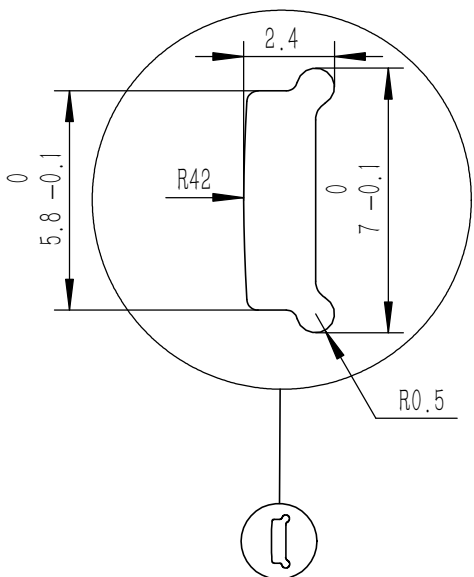

- 技术要求:
- 1、零件加工表面不应有划痕、擦伤等损伤零件表面的缺陷;
 - 2、去除毛刺飞边,锐角倒钝;
 - 3、未标注尺寸见3D数模。

业务代码:

Tolerances (未注公差):		Material (材料):	YONGU 永固	
0.5 to 6	± 0.1	6063-T5	Weight: (重量) (Kg)	0.00
6 to 30	± 0.2	Protection: (表面处理):		
30 to 120	± 0.3	Part Name (零/部件名称):	Drawing Number (图号):	
120 to 400	± 0.4	装饰条	YG-MH03-0000-003	
Break sharp edges (未注锐边倒角): Ch 0.05 to 0.25 x45°	Angular tolerances (未注角度公差):	Drawn by (绘图): 杨志业	Date (日期): 2023.12.23	Size: (图幅): A4
Position tolerances (未注位置公差): ±0.05	<6° ± 10' <30° ± 20' <120° ± 30' >120° ± 1°	Check by (校对):	Date (日期):	Scale (比例): 1:1
		Signature by (批准):	Date (日期):	Revision (版本): A1
				Sheet (页数): 1 / 1

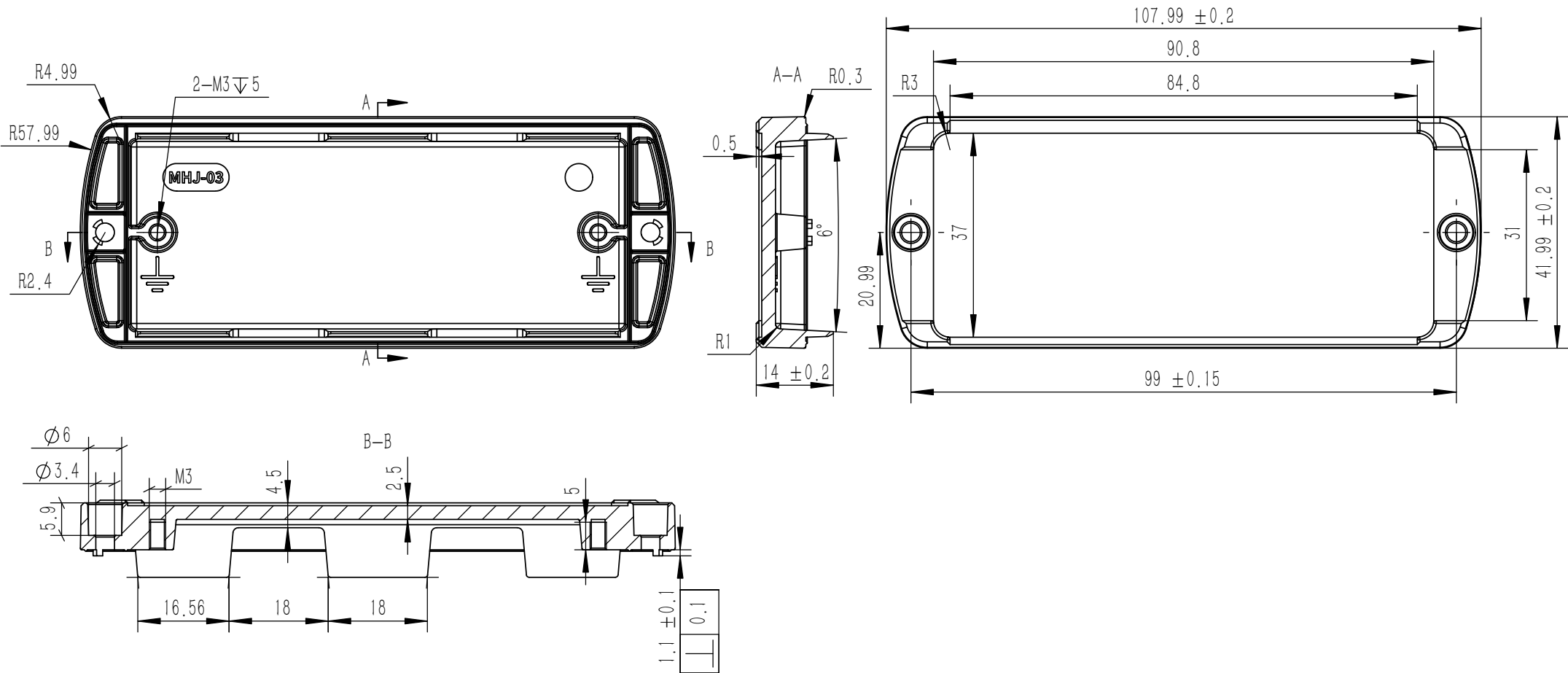

- 技术要求:
- 1、零件加工表面不应有划痕、擦伤等损伤零件表面的缺陷;
 - 2、去除毛刺飞边,锐角倒钝;
 - 3、未标注尺寸见3D数模。

业务代码:

Tolerances (未注公差): 0.5 to 6 ± 0.1 6 to 30 ± 0.2 30 to 120 ± 0.3 120 to 400 ± 0.4	Material (材料):	ADC12	YONGU 永固					
	Weight: (重量) (Kg)	0.05						
Break sharp edges (未注锐边倒角): Ch 0.05 to 0.25 x45° Position tolerances (未注位置公差): ±0.05	Protection: (表面处理):		Drawing Number (图号): YG-MH03-0000-004					
	Angular tolerances (未注角度公差): <6° ± 10' <30° ± 20' <120° ± 30' >120° ± 1°	Part Name (零/部件名称):		MH03压铸端盖				
	Drawn by (绘图):	杨志业	Date (日期):	2023.12.23	Size: (图幅):	A4	Sheet (页数):	1 / 1
	Check by (校对):		Date (日期):		Scale (比例):	1:1		
	Signature by (批准):		Date (日期):		Revision (版本):	A1		

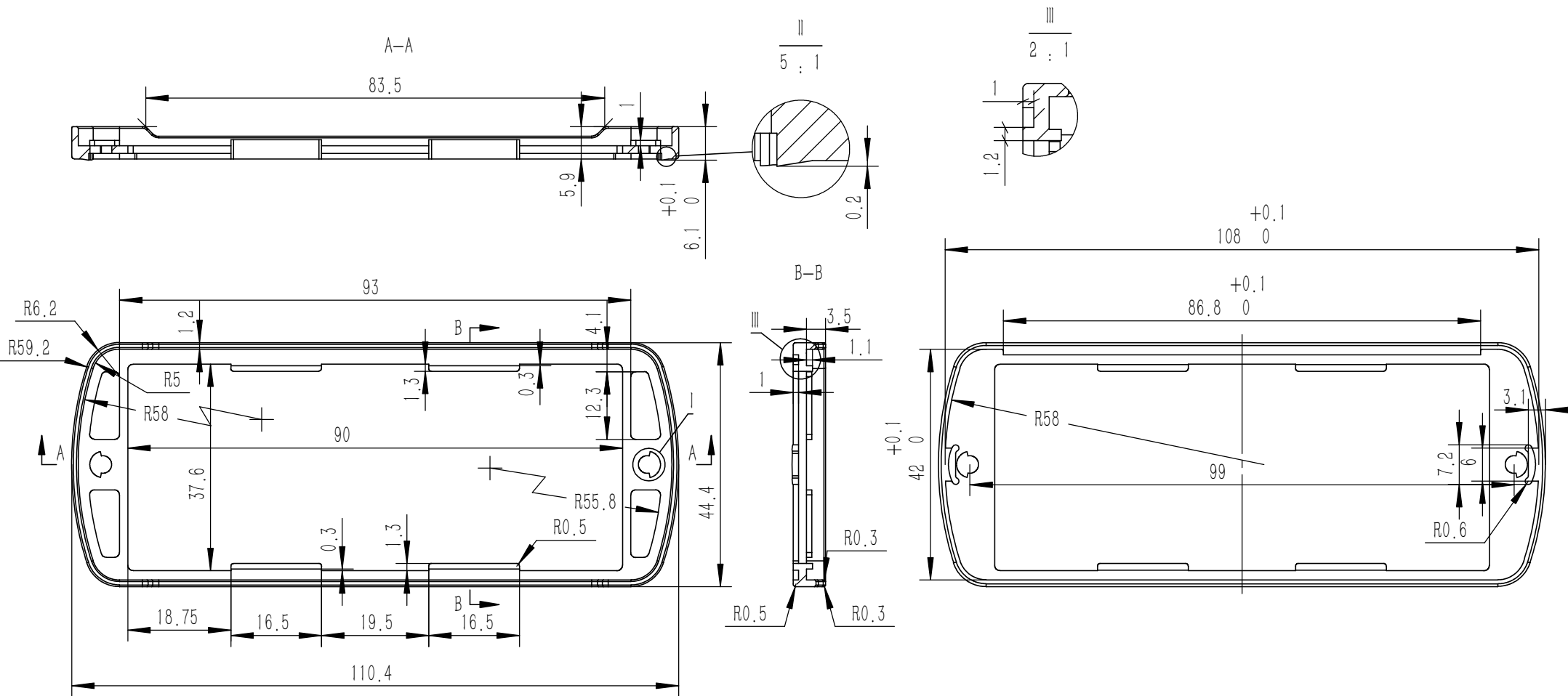

- 技术要求:
- 1、表面应光洁无损、色泽均匀,无明显凹痕、飞边、银丝、熔接痕等缺陷;
 - 2、未注公差尺寸的允许偏差按GB/T14486-93-MT5;
 - 3、浇口、溢边修剪后飞边 ≤ 0.3 ,且不得伤及本体;
 - 4、未标注尺寸见3D数模。

业务代码:

Break sharp edges (未注锐边倒角): Ch 0.05 to 0.25 x45°	Angular tolerances (未注角度公差): <6° ± 10' <30° ± 20' <120° ± 30' >120° ± 1°
Position tolerances (未注位置公差): ±0.05	

Tolerances (未注公差): 0.5 to 6 ± 0.1 6 to 30 ± 0.2 30 to 120 ± 0.3 120 to 400 ± 0.4	Material (材料): 硅胶	YONGU 永固	
	Weight: (重量) (Kg) 0.00		
	Part Name (零/部件名称): MH03红色密封圈	Drawing Number (图号): YG-MH-MFGJQ-003	
	Drawn by (绘图): 杨志业	Date (日期): 2023.12.22	Size: (图幅): A4
	Check by (校对):	Date (日期):	Scale (比例): 1:1
	Signature by (批准):	Date (日期):	Revision (版本): A2
			Sheet (页数): 1 / 1