

技术要求:

- 1、必须按照设计、工艺要求及本规定和有关标准进行装配;
- 2、所有零部件(包括外购、外协件)必须具有检验合格证方能进行装配;
- 3、零件在装配前必须清理和清洗干净,不得有毛刺、飞边、氧化皮、锈蚀、切屑、砂粒、灰尘和油污等,并应符合相应清洁度要求;
- 4、装配过程中零件不得磕碰、划伤和锈蚀;
- 5、油漆未干的零件不得进行装配;
- 6、相对运动的零件,装配时接触面间应加润滑油脂;
- 7、各零、部件装配后相对位置应准确。

业务代码:

| 6 | GB-T-70.1-2000-S-NL-M3X8 | 不锈钢内六角杯头螺丝M3X8 | SUS 304 | 8 | 0.001 | |
|--------------|--------------------------|-------------------|------------------|-------------|----------------|--------------|
| 5 | YG-TY-XJD-007 | 自粘橡胶垫9X19.3X1 | 硅橡胶 | 4 | 0.000 | |
| 4 | YG-L06A-0000-004 | 点胶密封圈 | 复合发泡胶 | 2 | 0.007 | |
| 3 | YG-L06A-0000-003 | 下盖 | 5052-H32 | 1 | 0.294 | |
| 2 | YG-L06A-0000-001 | 壳体 | 6063-T5 | 1 | 0.132 | |
| 1 | YG-L06A-0000-002 | 上盖 | 5052-H32 | 1 | 0.273 | |
| 序号 (Item) | 图号 (Drawing Number) | 名称 (Part Name) | 材料 (Material) | 数量 (QTY) | 单重 (Weight) | 备注 (Note) |

| | | | | | |
|--|---------------|------------------------------|--|----------------------|--|
| Tolerances (未注公差): | | Material (材料): (装配图) | | YONGU | |
| 0.5 to 6 ± 0.1 | 6 to 30 ± 0.2 | Weight: (重量) (Kg): 0.722 | | | |
| 30 to 120 ± 0.3 | | Protection: (表面处理): | | Drawing Number (图号): | |
| 120 to 400 ± 0.4 | | Part Name (零/部件名称): | | YG-L06A-0000-000 | |
| Break sharp edges (未注锐边倒角): Ch 0.05 to 0.25 x45° | | Angular tolerances (未注角度公差): | | L06A防水壳体 | |
| Position tolerances (未注位置公差): ±0.05 | | Angular tolerances (未注角度公差): | | Drawing Number (图号): | |
| | | Angular tolerances (未注角度公差): | | Size: (图幅): A2 | |
| | | Angular tolerances (未注角度公差): | | Scale (比例): 1:1 | |
| | | Angular tolerances (未注角度公差): | | Revision (版本): A1 | |
| | | Angular tolerances (未注角度公差): | | Sheet (页数): | |
| | | Angular tolerances (未注角度公差): | | 1 / 1 | |

| | |
|--|------------------------------|
| Break sharp edges (未注锐边倒角): Ch 0.05 to 0.25 x45° | Angular tolerances (未注角度公差): |
| Position tolerances (未注位置公差): ±0.05 | Angular tolerances (未注角度公差): |

| | | | |
|--------------------|-----------------------|-------------------|-------------------|
| Drawn by (绘图): 许宏彬 | Date (日期): 2020.10.30 | Size: (图幅): A2 | |
| Check by (校对): | Date (日期): | Scale (比例): 1:1 | |
| Signature by (批准): | Date (日期): | Revision (版本): A1 | Sheet (页数): 1 / 1 |

3.2

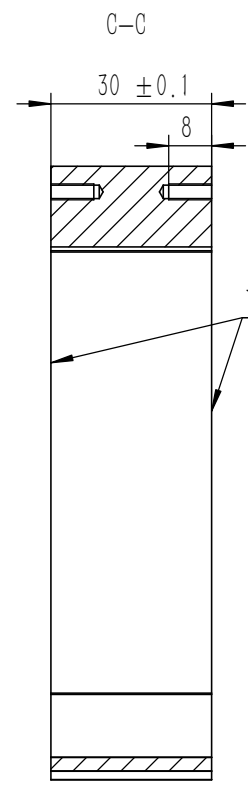
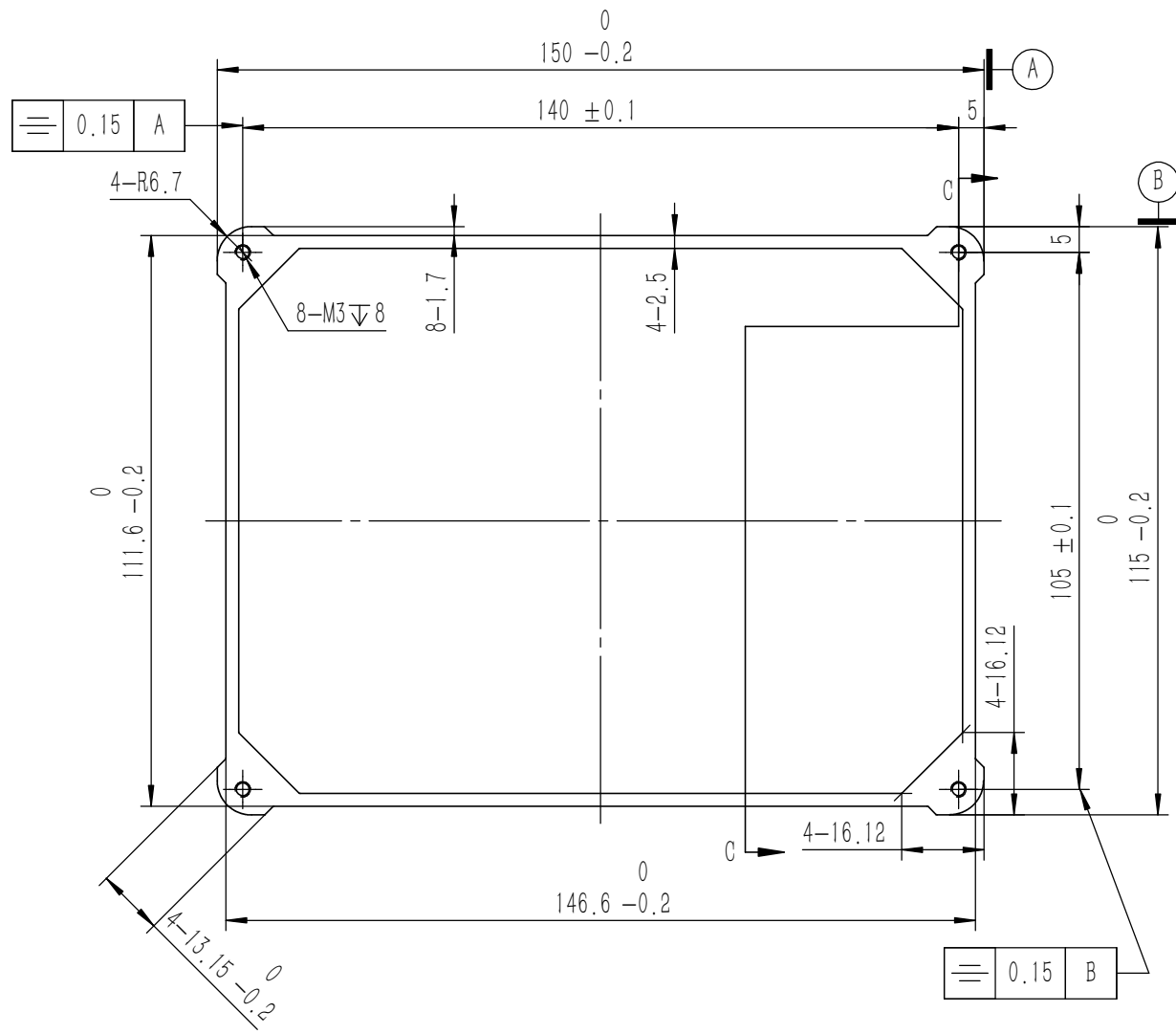

两端面要求光洁平整 (保证安装密封性)

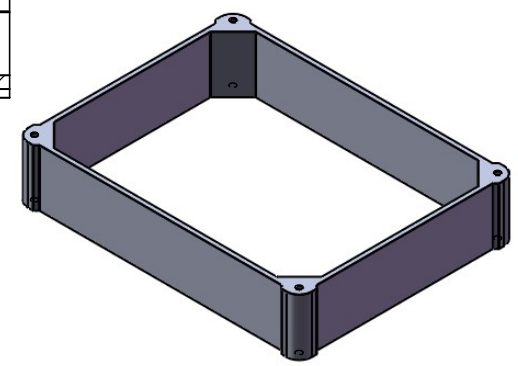

技术要求:

- 1、零件加工表面不应有划痕、擦伤等损伤零件表面的缺陷;
- 2、去除毛刺飞边, 锐角倒钝;
- 3、未标注尺寸见3D数模。

业务代码:

| | | | |
|---|--|---|--|
| Tolerances (未注公差): 0.5 to 6 ± 0.1 6 to 30 ± 0.2 30 to 120 ± 0.3 120 to 400 ± 0.4 | Material (材料): | 6063-T5 | YONGU 永固 |
| | Weight: (重量) (Kg): | 0.132 | |
| Break sharp edges (未注锐边倒角): Ch 0.05 to 0.25 x45° | Protection: (表面处理): | | Drawing Number (图号): YG-L06A-0000-001 |
| | Angular tolerances (未注角度公差): | 壳体 | |
| Position tolerances (未注位置公差): ±0.05 | Part Name (零/部件名称): | | Size: (图幅): A3 Scale (比例): 1:1 Revision (版本): A1 |
| | <6° ± 10' <30° ± 20' <120° ± 30' >120° ± 1° | Drawn by (绘图): 许宏彬 Date (日期): 2021.01.30 | |
| | Check by (校对): Signature by (批准): | Date (日期): Date (日期): | |

3.2

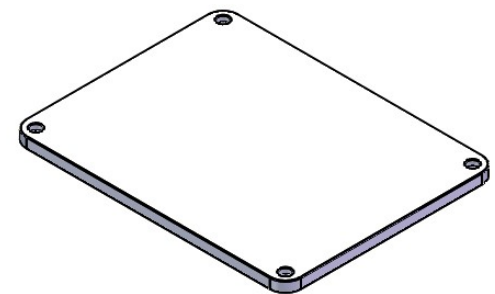
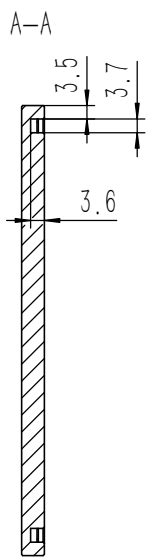
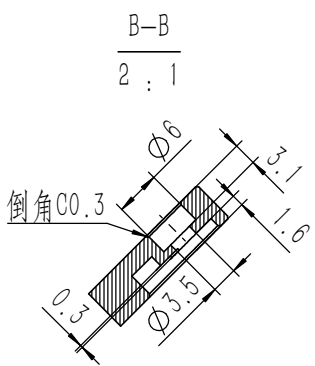
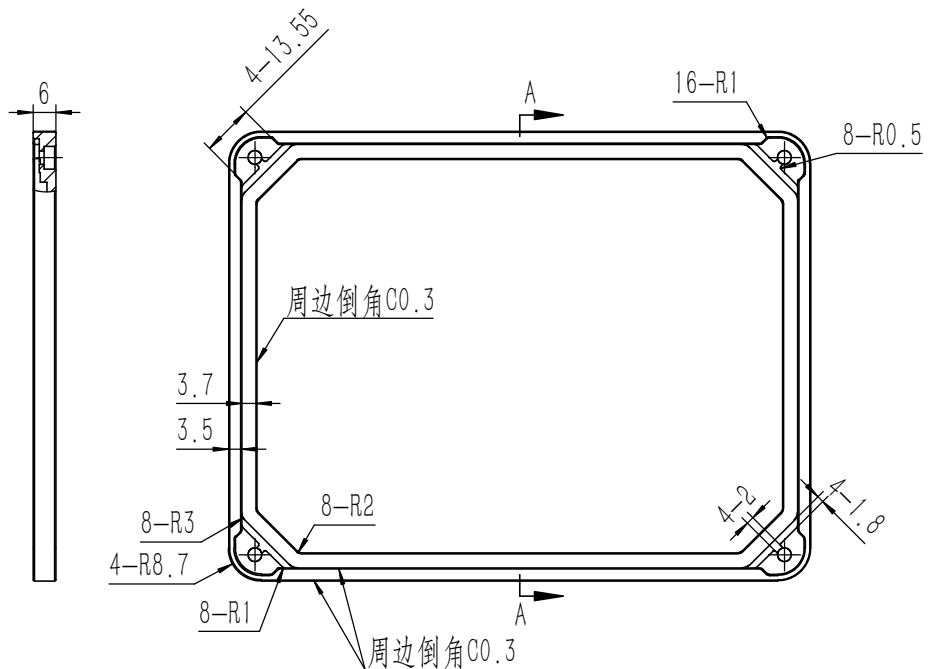
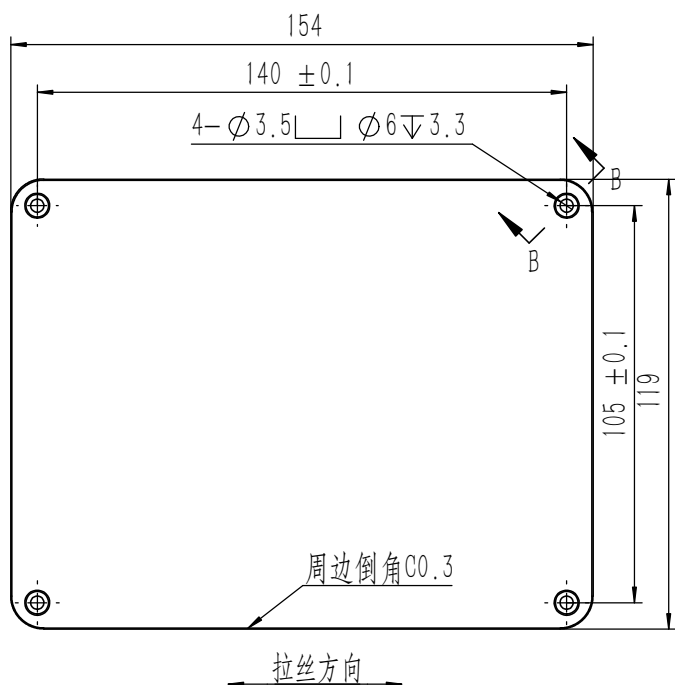

- 技术要求:
- 1、零件加工表面不应有划痕、擦伤等损伤零件表面的缺陷;
 - 2、去除毛刺飞边, 锐角倒钝;
 - 3、未标注尺寸见3D数模;
 - 4、靠近防水槽外边打防水胶, 防水胶宽度3.7mm高度3.6±0.2mm。

业务代码:

| | |
|--|---|
| Break sharp edges (未注锐边倒角): Ch 0.05 to 0.25 x45° | Angular tolerances (未注角度公差): <6° ± 10' <30° ± 20' <120° ± 30' >120° ± 1° |
| Position tolerances (未注位置公差): ±0.05 | |

| | | |
|---|--------------------------|---------------------------------------|
| Tolerances (未注公差): 0.5 to 6 ± 0.1 6 to 30 ± 0.2 30 to 120 ± 0.3 120 to 400 ± 0.4 | Material (材料): 5052-H32 | YONGU |
| | Weight: (重量) (Kg): 0.273 | |
| | Protection: (表面处理): | |
| | Part Name (零/部件名称): 上盖 | Drawing Number (图号): YG-L06A-0000-002 |
| | Drawn by (绘图): 许宏彬 | Date (日期): 2021.04.22 |
| | Check by (校对): | Date (日期): |
| | Signature by (批准): | Date (日期): |
| | | Size: (图幅): A2 |
| | | Scale (比例): 1:1 |
| | | Revision (版本): A1 |
| | | Sheet (页数): 1 / 1 |

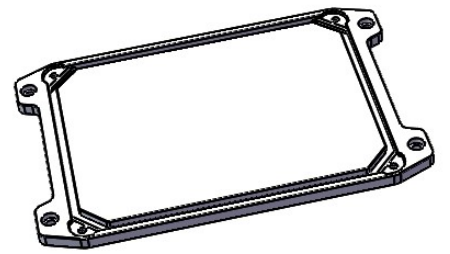
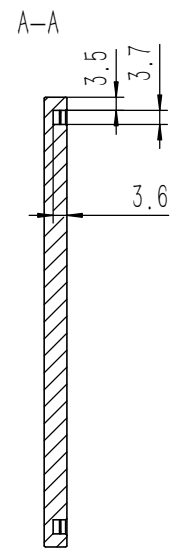
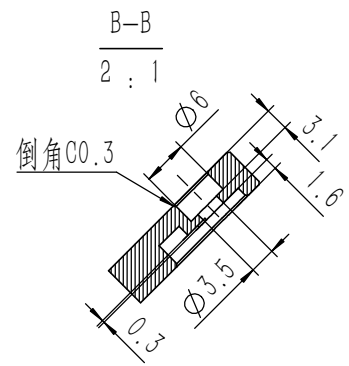
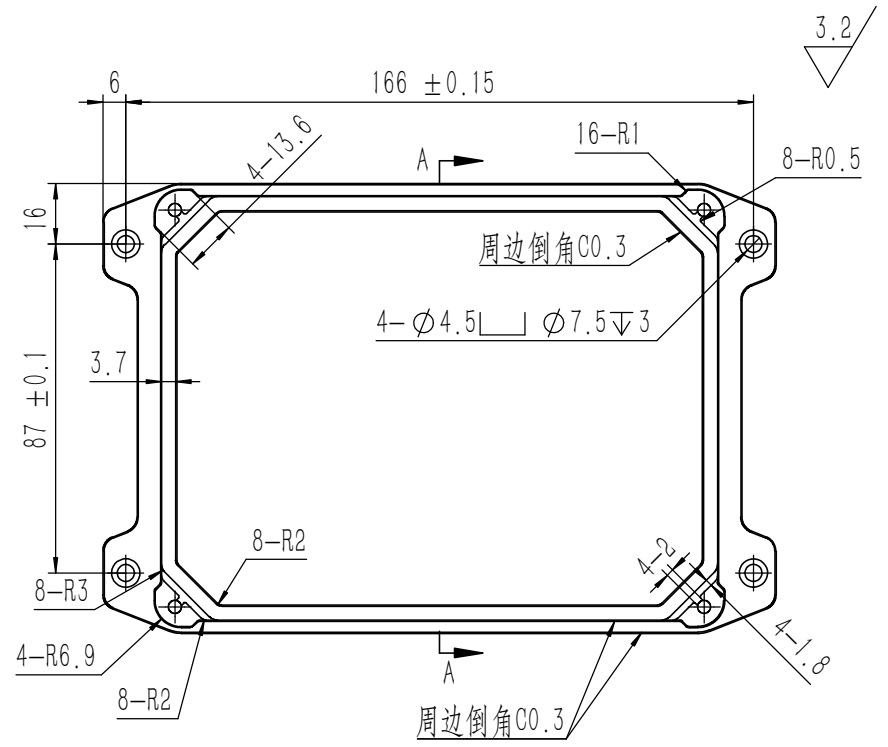
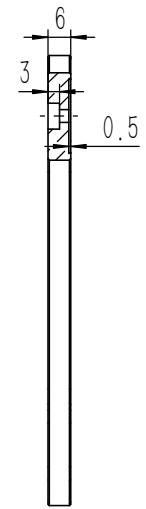
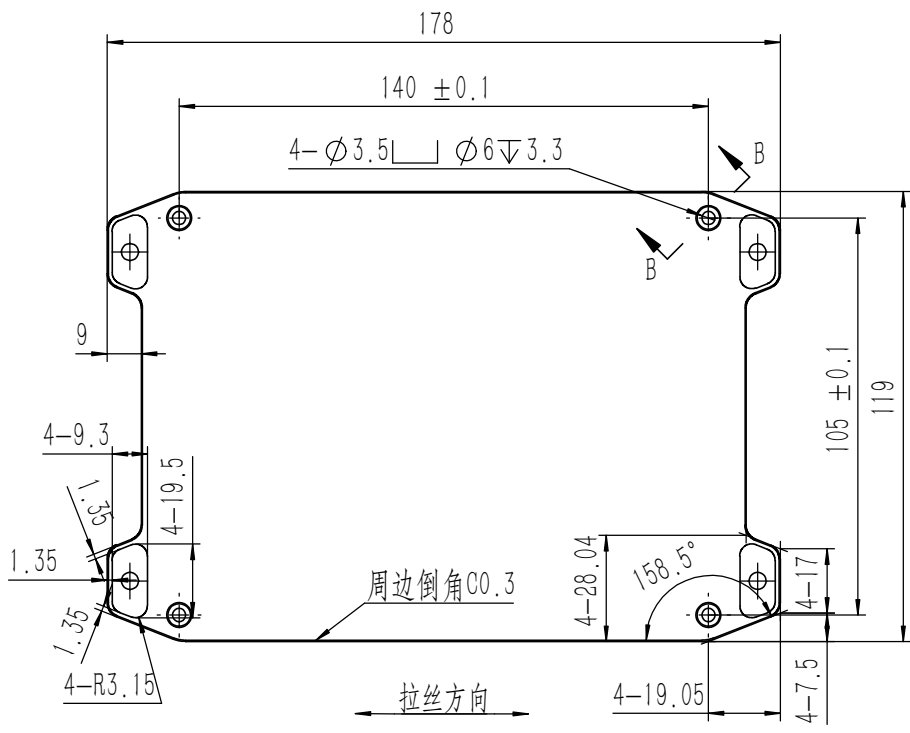

- 技术要求:
- 零件加工表面不应有划痕、擦伤等损伤零件表面的缺陷;
 - 去除毛刺飞边, 锐角倒钝;
 - 未标注尺寸见3D数模;
 - 靠近防水槽外边打防水胶, 防水胶宽度3.7mm高度3.6±0.2mm。

业务代码:

| | |
|--|---|
| Break sharp edges (未注锐边倒角): Ch 0.05 to 0.25 x45° | Angular tolerances (未注角度公差): <6° ± 10' <30° ± 20' <120° ± 30' >120° ± 1° |
| Position tolerances (未注位置公差): ±0.05 | |

| | | |
|---|---------------------------------------|-------------------|
| Tolerances (未注公差): 0.5 to 6 ± 0.1 6 to 30 ± 0.2 30 to 120 ± 0.3 120 to 400 ± 0.4 | Material (材料): 5052-H32 | YONGU |
| Weight: (重量) (Kg): 0.294 | Protection: (表面处理): | |
| Part Name (零/部件名称): | Drawing Number (图号): YG-L06A-0000-003 | |
| 下盖 | | |
| Drawn by (绘图): 许宏彬 | Date (日期): 2021.04.22 | Size: (图幅): A2 |
| Check by (校对): | Date (日期): | Scale (比例): 1:1 |
| Signature by (批准): | Date (日期): | Revision (版本): A1 |
| | | Sheet (页数): 1 / 1 |