

9	YG-C26C-0000-002	后面板	5052-H32	1	0.305	
8	BSO-M3-5-ZI-D5.4	盲孔压铆螺柱镀白锌M3X5	普通碳钢	6	0.001	
7	S-M3-1-ZI	压铆螺母镀白锌M3X1	普通碳钢	14	0.3750	
6	GB-T-973-1976-C-NI-M3X4	碳钢镀镍十字大扁头螺丝M3X4	普通碳钢	7	0.0005	
5	YG-C26C-0000-001	前面板	6063-T5	1	0.591	
4	YG-C26C-0000-004	底壳	冷轧板	1	1.722	
3	YG-C26C-0000-005	安装耳	6063-T5	2	0.050	
2	YG-C26C-0000-003	上盖板	冷轧板	1	1.251	
1	GB-T-819.1-2000-C-NI-M3X6	碳钢镀镍十字沉头螺丝M3X6	普通碳钢	14	0.0004	
序号	图号	名称	材料	数量	单重	备注

技术要求:

- 1、必须按照设计、工艺要求及本规定和有关标准进行装配;
- 2、所有零部件(包括外购、外协件)必须具有检验合格证方能进行装配;
- 3、零件在装配前必须清理和清洗干净,不得有毛刺、飞边、氧化皮、锈蚀、切屑、砂粒、灰尘和油污等,并应符合相应清洁度要求;
- 4、装配过程中零件不得磕碰、划伤和锈蚀;
- 5、油漆未干的零件不得进行装配;
- 6、相对运动的零件,装配时接触面间应加润滑油脂;
- 7、各零、部件装配后相对位置应准确。

Break sharp edges (未注锐边倒角): Ch 0.05 to 0.25 x45°	Angular tolerances (未注角度公差): <6° ± 10' <30° ± 20' <120° ± 30' >120° ± 1°
Position tolerances (未注位置公差): ±0.05	

Tolerances (未注公差): 0.5 to 6 ± 0.1 6 to 30 ± 0.2 30 to 120 ± 0.3 120 to 400 ± 0.4	Material (材料): Weight: (重量) (Kg): Protection: (表面处理): Part Name (零/部件名称):	(装配图) 3.990 C26C机箱	Material (材料): Quantity (数量): Weight (单重): Remarks (备注):
Drawing Number (图号): YG-C26C-0000-000		Drawn by (绘图): 邓展锋 Date (日期): 2020.05.27	Size (图幅): A0 Scale (比例): 1:1.2 Revision (版本): A2
Signature by (校对): Signature by (批准):		Date (日期): Date (日期):	Sheet (页数): 1 / 1



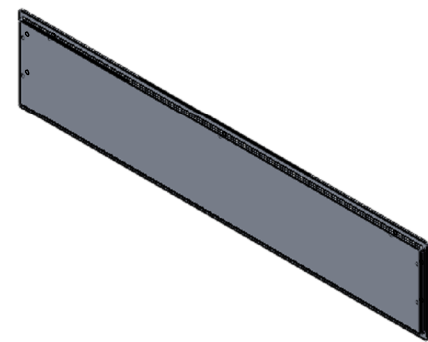
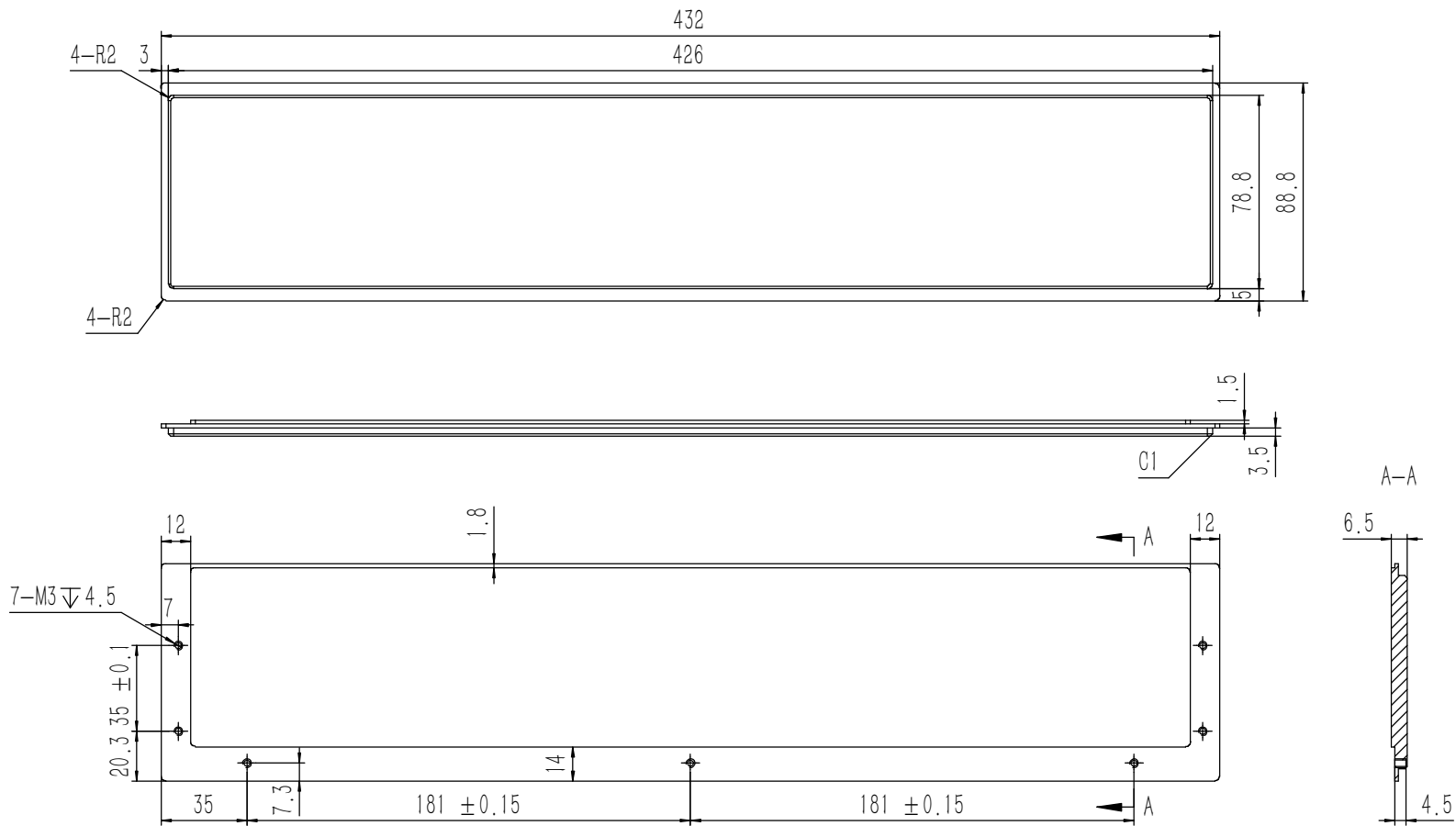

技术要求:



- 1、零件加工表面不应有划痕、擦伤等损伤零件表面的缺陷;
- 2、去除毛刺飞边, 锐角倒钝;
- 3、未标注尺寸见3D数模。

Tolerances (未注公差): 0.5 to 6 ± 0.1 6 to 30 ± 0.2 30 to 120 ± 0.3 120 to 400 ± 0.4	Material (材料):	6063-T5	
	Weight: (重量) (Kg):	0.591	
Break sharp edges (未注锐边倒角): Ch 0.05 to 0.25 x45°	Protection: (表面处理):		
	Position tolerances (未注位置公差): ± 0.05	Part Name (零/部件名称):	前面板
Angular tolerances (未注角度公差): <6° ± 10' <30° ± 20' <120° ± 30' >120° ± 1°	Signature by (批准):	邓展锋	2020.05.27
	Check by (校对):		
Drawing Number (图号):		YG-C26C-0000-001	
Size: (图幅):		A1	Sheet (页数):
Scale (比例):		1:1	1 / 1
Revision (版本):		A1	

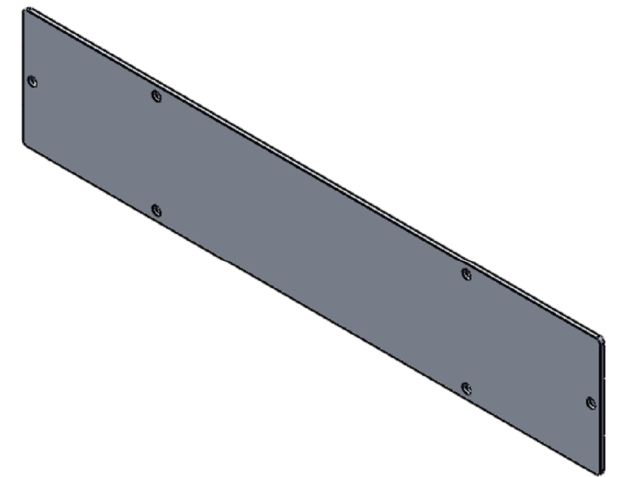
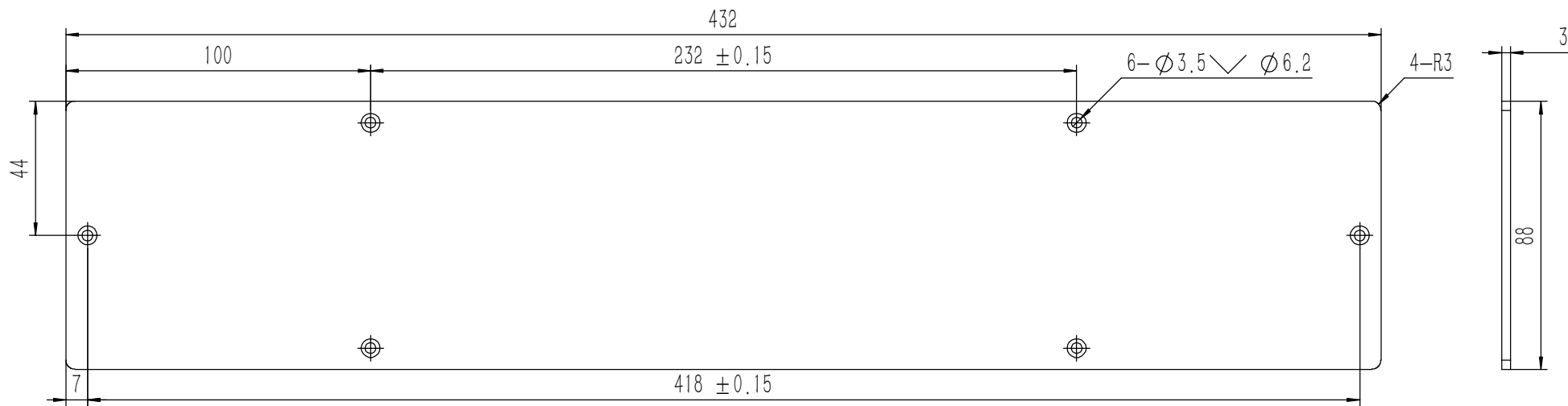
YONGU 永固



- 技术要求:
- 1、零件加工表面不应有划痕、擦伤等损伤零件表面的缺陷;
 - 2、去除毛刺飞边, 锐角倒钝;
 - 3、未标注尺寸见3D数模。

<table border="1"> <tr> <td>Break sharp edges (未注锐边倒角): Ch 0.05 to 0.25 x45°</td> <td>Angular tolerances (未注角度公差): <6° ± 10' <30° ± 20' <120° ± 30' >120° ± 1°</td> </tr> <tr> <td>Position tolerances (未注位置公差): ±0.05</td> <td></td> </tr> </table>	Break sharp edges (未注锐边倒角): Ch 0.05 to 0.25 x45°	Angular tolerances (未注角度公差): <6° ± 10' <30° ± 20' <120° ± 30' >120° ± 1°	Position tolerances (未注位置公差): ±0.05		<table border="1"> <tr> <td>Tolerances (未注公差):</td> <td>Material (材料): 5052-H32</td> </tr> <tr> <td>0.5 to 6 ± 0.1</td> <td>Weight: (重量) (Kg): 0.305</td> </tr> <tr> <td>6 to 30 ± 0.2</td> <td>Protection: (表面处理):</td> </tr> <tr> <td>30 to 120 ± 0.3</td> <td>Part Name (零/部件名称):</td> </tr> <tr> <td>120 to 400 ± 0.4</td> <td>后面板</td> </tr> </table>	Tolerances (未注公差):	Material (材料): 5052-H32	0.5 to 6 ± 0.1	Weight: (重量) (Kg): 0.305	6 to 30 ± 0.2	Protection: (表面处理):	30 to 120 ± 0.3	Part Name (零/部件名称):	120 to 400 ± 0.4	后面板	<table border="1"> <tr> <td colspan="2">  </td> </tr> <tr> <td colspan="2">Drawing Number (图号): YG-C26C-0000-002</td> </tr> <tr> <td>Size: (图幅): A2</td> <td>Sheet (页数): 1 / 1</td> </tr> <tr> <td>Scale (比例): 1:1</td> <td>Revision (版本): A1</td> </tr> </table>			Drawing Number (图号): YG-C26C-0000-002		Size: (图幅): A2	Sheet (页数): 1 / 1	Scale (比例): 1:1	Revision (版本): A1
	Break sharp edges (未注锐边倒角): Ch 0.05 to 0.25 x45°	Angular tolerances (未注角度公差): <6° ± 10' <30° ± 20' <120° ± 30' >120° ± 1°																						
	Position tolerances (未注位置公差): ±0.05																							
	Tolerances (未注公差):	Material (材料): 5052-H32																						
0.5 to 6 ± 0.1	Weight: (重量) (Kg): 0.305																							
6 to 30 ± 0.2	Protection: (表面处理):																							
30 to 120 ± 0.3	Part Name (零/部件名称):																							
120 to 400 ± 0.4	后面板																							
																								
Drawing Number (图号): YG-C26C-0000-002																								
Size: (图幅): A2	Sheet (页数): 1 / 1																							
Scale (比例): 1:1	Revision (版本): A1																							
	<table border="1"> <tr> <td>Drawn by (绘图): 邓展锋</td> <td>Date (日期): 2020.05.27</td> </tr> <tr> <td>Check by (校对):</td> <td>Date (日期):</td> </tr> <tr> <td>Signature by (批准):</td> <td>Date (日期):</td> </tr> </table>	Drawn by (绘图): 邓展锋	Date (日期): 2020.05.27	Check by (校对):	Date (日期):	Signature by (批准):	Date (日期):																	
Drawn by (绘图): 邓展锋	Date (日期): 2020.05.27																							
Check by (校对):	Date (日期):																							
Signature by (批准):	Date (日期):																							

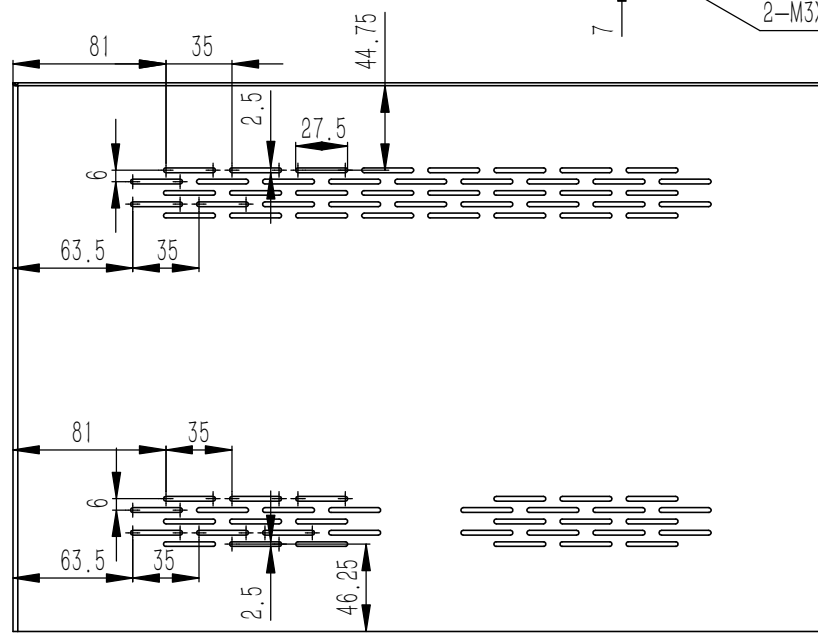
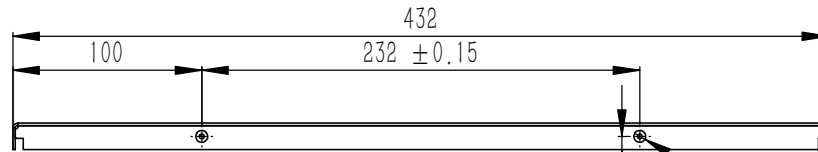
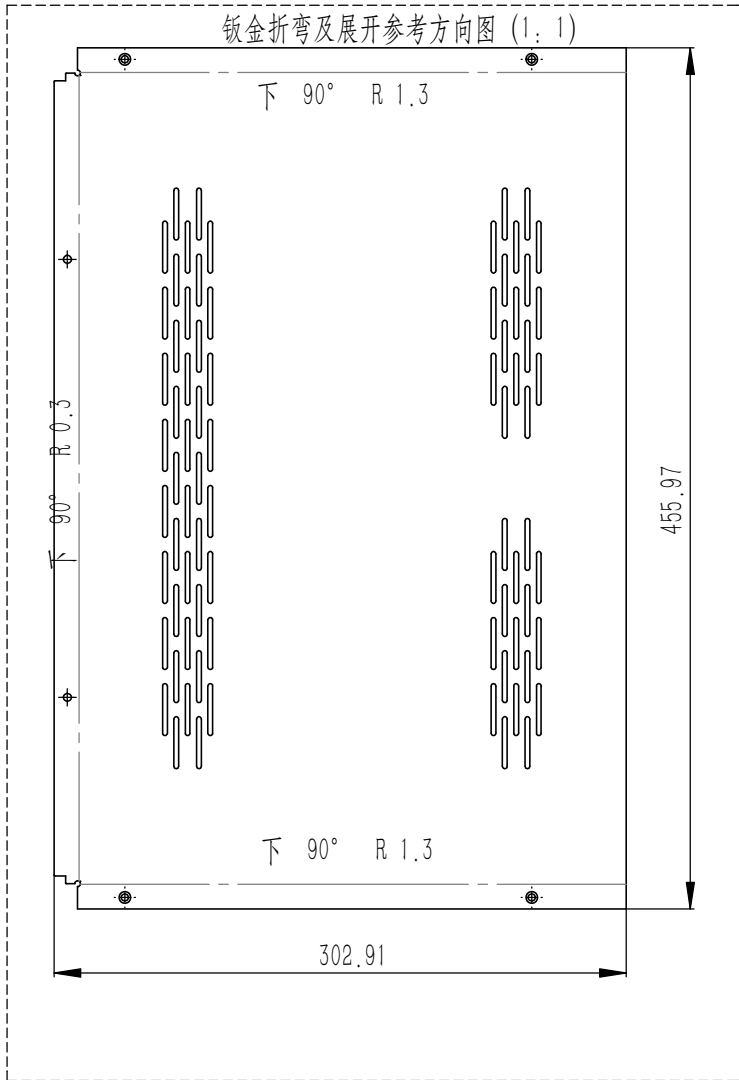

2-M3X1 压铆螺母底孔 $\phi 4.2$

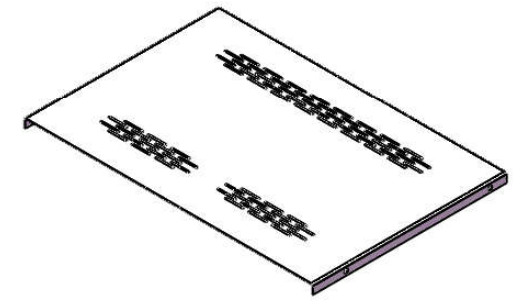
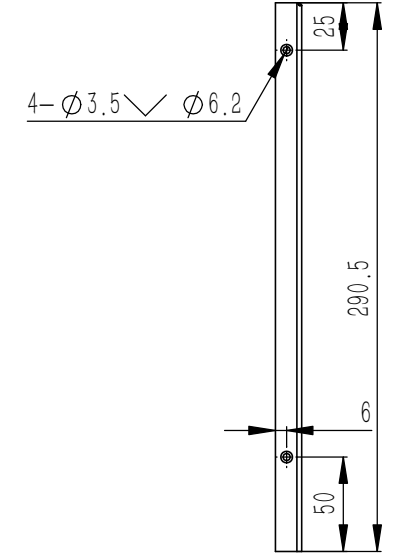

技术要求:

- 1、零件加工表面不应有划痕、擦伤等损伤零件表面的缺陷;
- 2、去除毛刺飞边, 锐角倒钝;
- 3、未标注尺寸见3D数模。

Tolerances (未注公差): 0.5 to 6 ± 0.1 6 to 30 ± 0.2 30 to 120 ± 0.3 120 to 400 ± 0.4	Material (材料):	冷轧板	
	Weight: (重量) (Kg):	1.251	
Break sharp edges (未注锐边倒角): Ch 0.05 to 0.25 x45°	Protection: (表面处理):		
	Position tolerances (未注位置公差): ±0.05	Part Name (零/部件名称):	上盖板
Angular tolerances (未注角度公差): <6° ± 10' <30° ± 20' <120° ± 30' >120° ± 1°	Drawn by (绘图):	邓展锋	Date (日期): 2020.05.27
	Drawing Number (图号): YG-C26C-0000-003	Check by (校对):	
Signature by (批准):			Date (日期):
	Size (图幅):	A0	Scale (比例): 1:1
	Revision (版本):	A2	Sheet (页数): 1 / 1



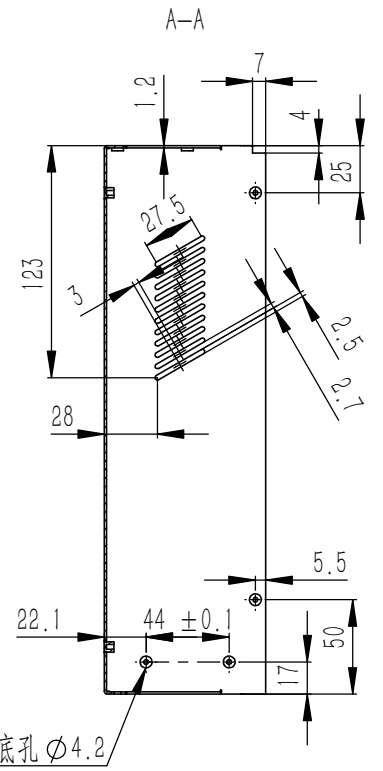
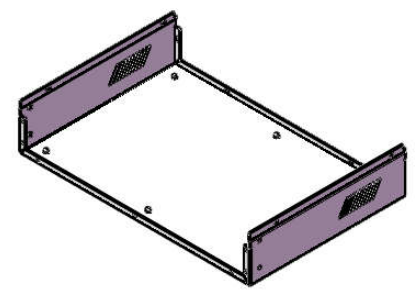
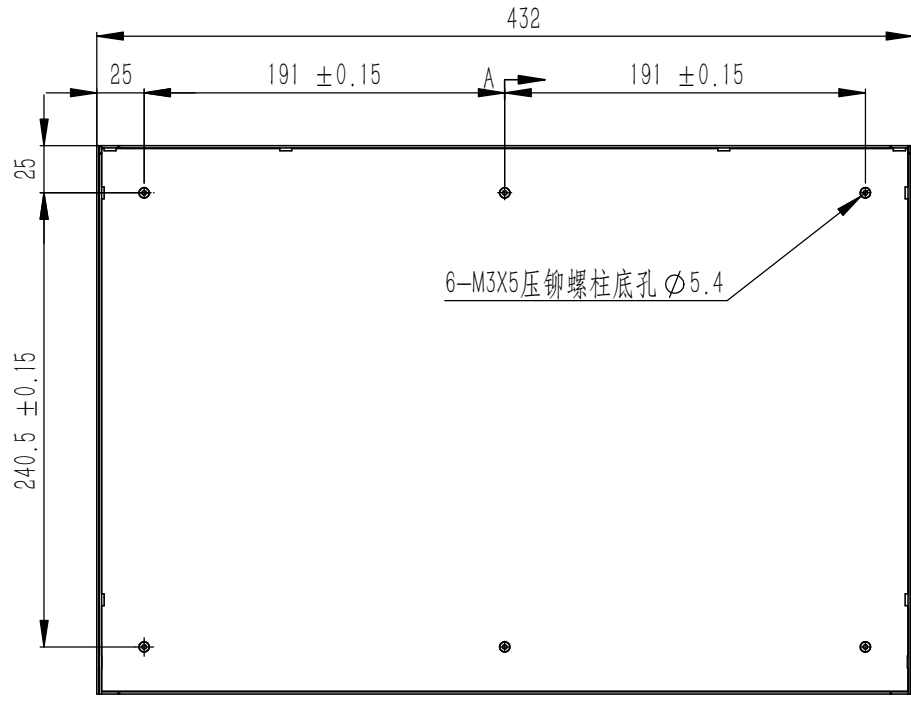
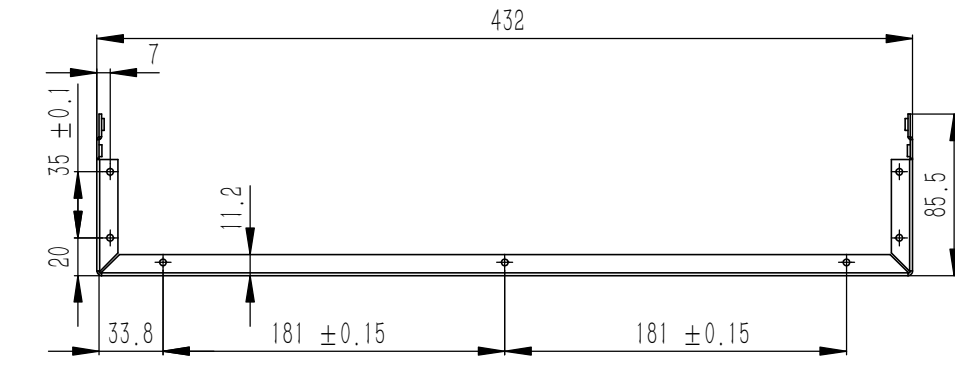
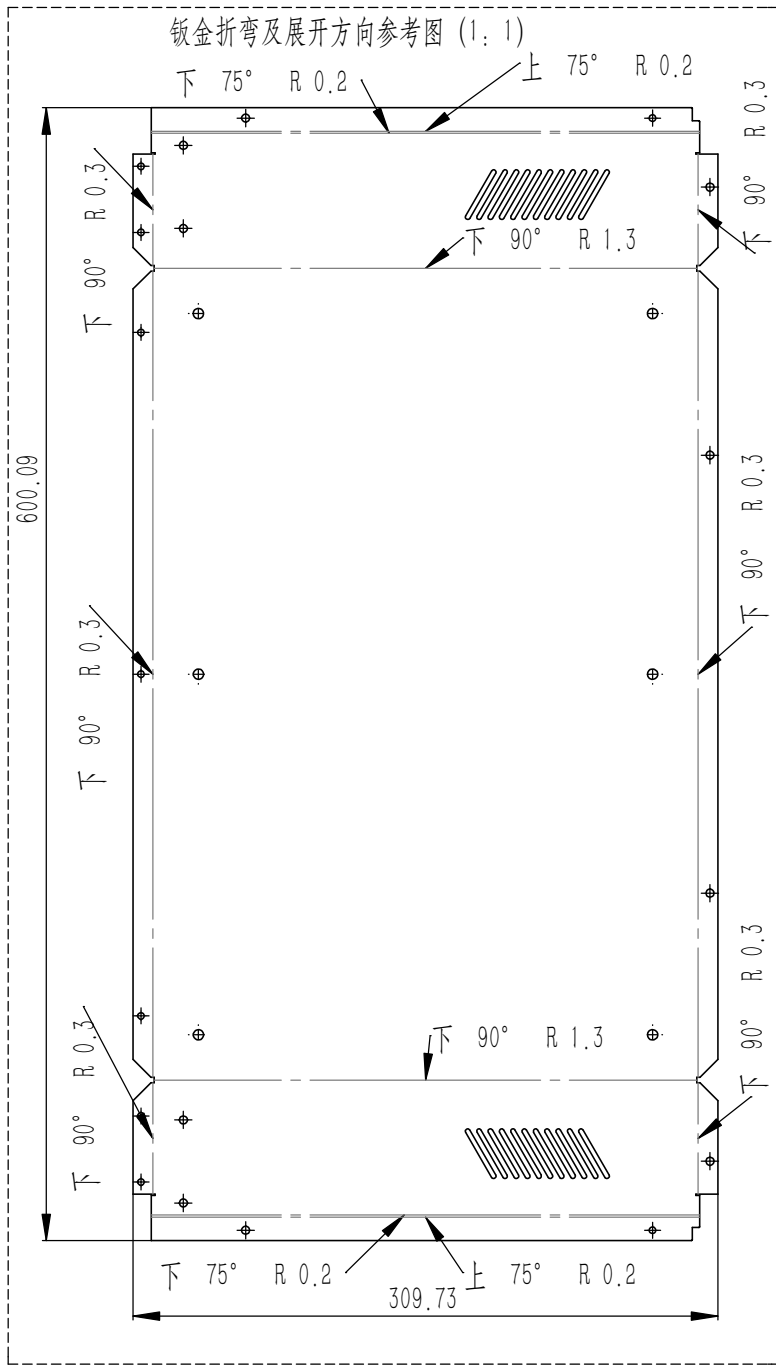

技术要求:

- 1、零件加工表面不应有划痕、擦伤等损伤零件表面的缺陷;
- 2、去除毛刺飞边, 锐角倒钝;
- 3、未标注尺寸见3D数模。

Tolerances (未注公差):	
0.5 to 6	± 0.1
6 to 30	± 0.2
30 to 120	± 0.3
120 to 400	± 0.4
Break sharp edges (未注锐边倒角): Ch 0.05 to 0.25 x45°	
Angular tolerances (未注角度公差):	
<6°	± 10'
<30°	± 20'
<120°	± 30'
>120°	± 1°
Position tolerances (未注位置公差): ± 0.05	

Material (材料):	冷轧板
Weight: (重量) (Kg):	1.722
Protection: (表面处理):	
Part Name (零/部件名称):	底壳
Drawn by (绘图): 邓展锋	Date (日期): 2020.05.27
Check by (校对):	Date (日期):
Signature by (批准):	Date (日期):

<h1>YONGU 永固</h1>		Drawing Number (图号):	
		YG-C26C-0000-004	
Size (图幅):	A0	Sheet (页数):	1 / 1
Scale (比例):	1:1	Revision (版本):	A2

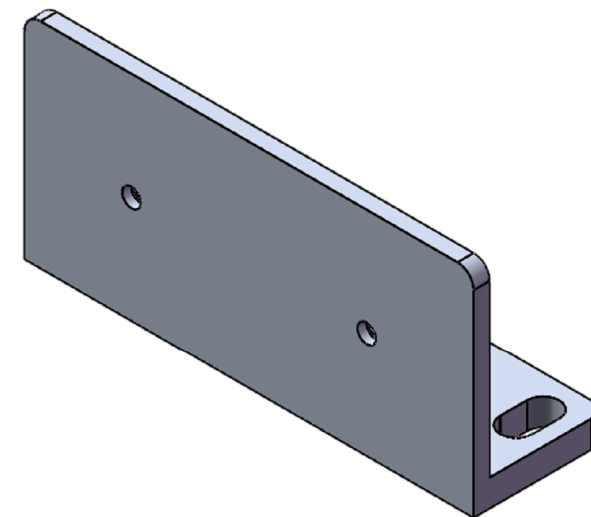
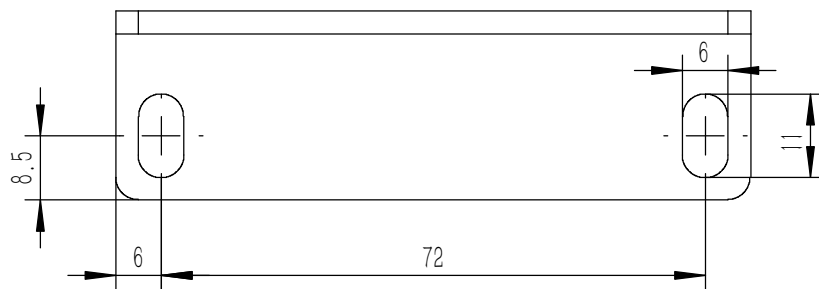
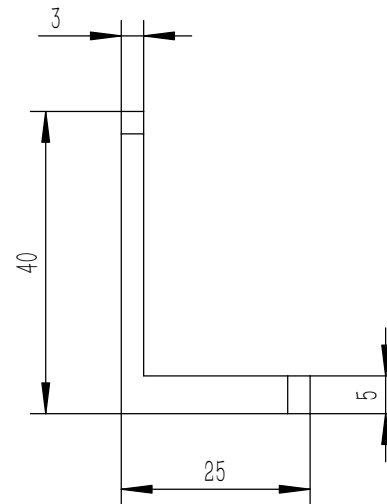
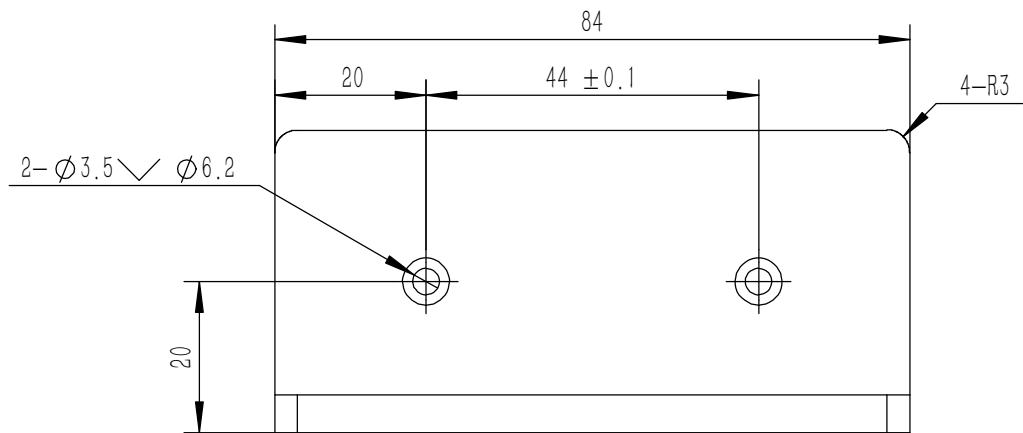

技术要求:

- 1、零件加工表面不应有划痕、擦伤等损伤零件表面的缺陷;
- 2、去除毛刺飞边, 锐角倒钝;
- 3、未标注尺寸见3D数模。

Tolerances (未注公差): 0.5 to 6 ± 0.1 6 to 30 ± 0.2 30 to 120 ± 0.3 120 to 400 ± 0.4	Material (材料): 6063-T5	YONGU 永固	
	Weight: (重量) (Kg) 0.050		
Break sharp edges (未注锐边倒角): Ch 0.05 to 0.25 x45°	Protection: (表面处理):	Part Name (零/部件名称): 安装耳	
	Position tolerances (未注位置公差): ±0.05	Angular tolerances (未注角度公差): <6° ± 10' <30° ± 20' <120° ± 30' >120° ± 1°	Drawing Number (图号): YG-C26C-0000-005
	Drawn by (绘图): 邓展锋	Date (日期): 2020.05.27	Size: (图幅): A4
	Check by (校对):	Date (日期):	Scale (比例): 1:1
	Signature by (批准):	Date (日期):	Revision (版本): A1
			Sheet (页数): 1 / 1