

21	DIN-9250-S-NL-M3	不锈钢防松垫圈	SUS 304	8	0.000	
20	GB-T-973-1976-C-NI-M3X12	碳钢镀锌十字大扁头螺丝M3X12	普通碳钢	16	0.001	
19	GB-T-70.3-2000-C-NI-M3X6	芳生镀白镍内六角沉头螺丝M3X6	普通碳钢	4	0.0004	
18	YG-TY-A12-002	前后面板-115H	5052-H32	2	0.413	
17	YG-TY-A07-002	后防护条-115H	5052-H32	2	0.048	
16	S-M3-1-ZI	压铆螺母镀白锌M3X1	普通碳钢	8	0.3750	
15	YG-TY-B05-001	B包角1	6063-T5	4	0.035	
14	YG-TY-B03-002	B组合侧板	6063-T5	4	0.161	
13	YG-TY-A09-002	侧板连接件	电解板	2	0.030	
12	BSO-M3-5-ZI-D5.4	压铆螺柱 M3X5	普通碳钢	6	0.001	
11	GB-T-973-1976-C-NI-M3X4	碳钢镀锌十字大扁头螺丝M3X4	普通碳钢	21	0.0005	
10	YG-TY-A13-001	A垫板	5052-H32	1	0.184	
9	YG-TY-A08-002	A侧板固定件115H	6063-T5	4	0.041	
8	YG-TY-B01-001	上下盖板	5052-H32	1	0.343	
7	YG-TY-A11-001	面板下固定件1	电解板	2	0.039	
6	YG-TY-A06-002	拉手-115H	6063-T5	2	0.092	
5	YG-TY-A10-001	面板上固定件1	电解板	2	0.033	
4	YG-TY-B02-001	上盖板	5052-H32	1	0.323	
3	GB-T-973-1976-C-NI-M3X6	碳钢镀锌十字大扁头螺丝M3X6	普通碳钢	16	0.0006	
2	YG-TY-XJD-001	自粘胶垫35X11X3	硅橡胶	8	0.0013	
1	YG-TY-B05-002	B包角2	6063-T5	4	0.035	
序号	图号	名称	材料	数量	单重	备注

#### 技术要求:

- 1、必须按照设计、工艺要求及本规定和有关标准进行装配;
- 2、所有零部件(包括外购、外协件)必须具有检验合格证方能进行装配;
- 3、零件在装配前必须清理和清洗干净,不得有毛刺、飞边、氧化皮、锈蚀、切屑、砂粒、灰尘和油污等,并应符合相应清洁度要求;
- 4、装配过程中零件不得磕碰、划伤和锈蚀;
- 5、油漆未干的零件不得进行装配;
- 6、相对运动的零件,装配时接触面间应加润滑油脂;
- 7、各零、部件装配后相对位置应准确。

Break sharp edges (未注锐边倒角): Ch 0.05 to 0.25 x45°	Angular tolerances (未注角度公差): <6° ± 10' <30° ± 20' <120° ± 30' >120° ± 1°
Position tolerances (未注位置公差): ± 0.05	

Tolerances (未注公差): 0.5 to 6 ± 0.1 6 to 30 ± 0.2 30 to 120 ± 0.3 120 to 400 ± 0.4	Material (材料): (装配图)	<b>YONGU</b> 永固
Weight: (重量) (Kg): 3.301	Weight: (重量) (Kg): 3.301	
Protection: (表面处理):	Protection: (表面处理):	
Part Name (零/部件名称):	B02机箱	Drawing Number (图号): YG-B02-1000-000
Drawn by (绘图): 邓展锋	Date (日期): 2020.05.21	Size (图幅): A0
Check by (校对):	Date (日期):	Scale (比例): 1:1
Signature by (批准):	Date (日期):	Revision (版本): A1
		Sheet (页数): 1 / 1

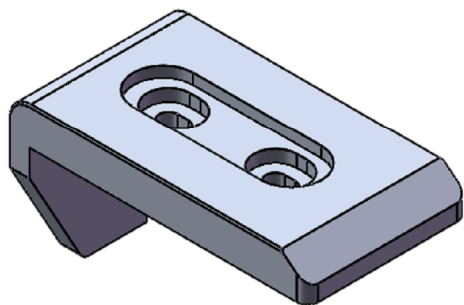
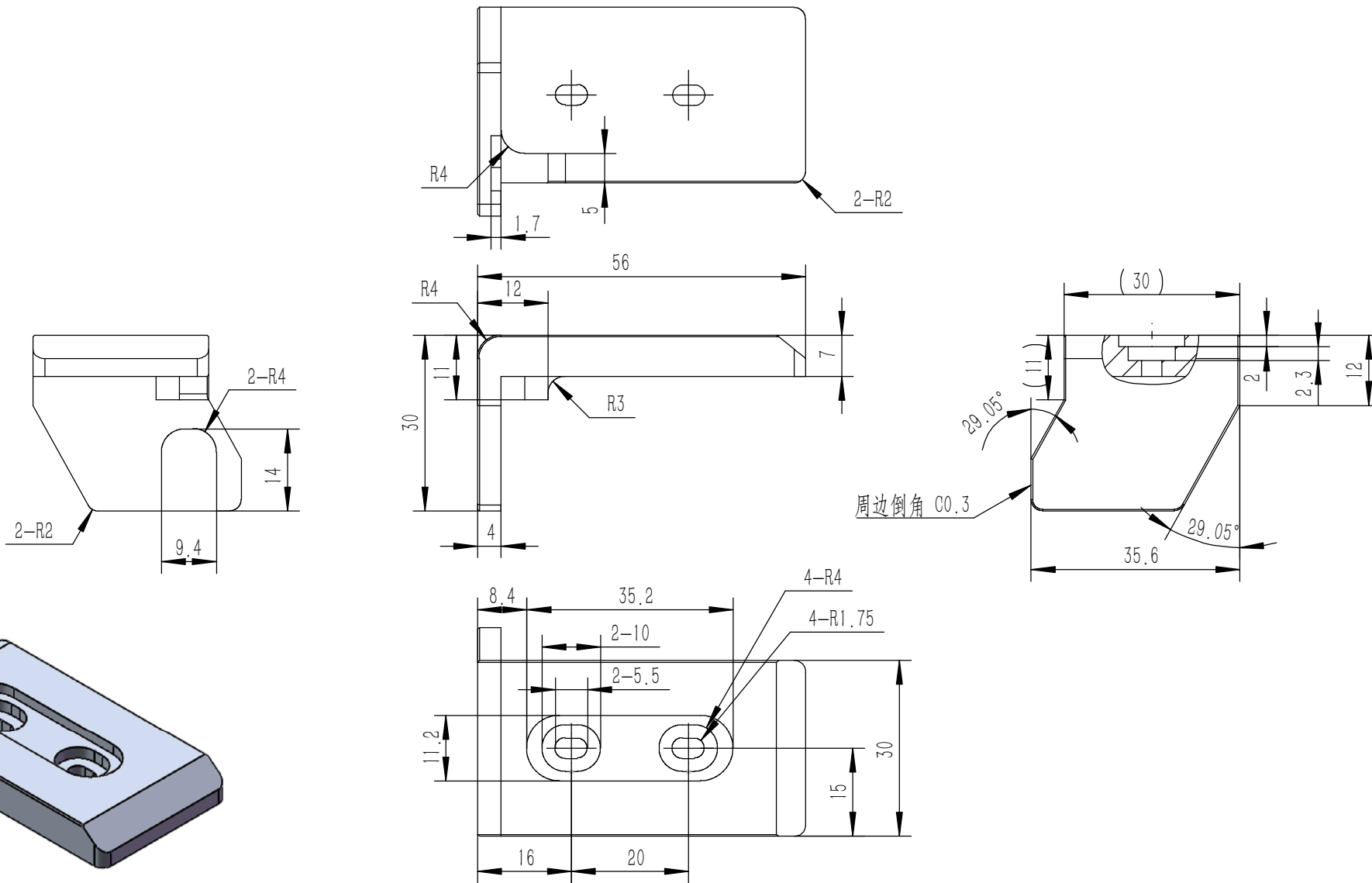

**技术要求:**

- 1、零件加工表面不应有划痕、擦伤等损伤零件表面的缺陷;
- 2、去除毛刺飞边,锐角倒钝;
- 3、未标注尺寸见3D数模。

Tolerances (未注公差): 0.5 to 6 ± 0.1 6 to 30 ± 0.2 30 to 120 ± 0.3 120 to 400 ± 0.4	Material (材料): 6063-T5	<b>YONGU</b> 永固	
	Weight: (重量) (Kg) 0.035		
Break sharp edges (未注锐边倒角): Ch 0.05 to 0.25 x45°	Protection: (表面处理):	Drawing Number (图号): YG-TY-B05-002	
	Part Name (零/部件名称): B包角2	Drawn by (绘图):	Date (日期): 2020.05.18
Position tolerances (未注位置公差): ±0.05	Angular tolerances (未注角度公差): <6° ± 10' <30° ± 20' <120° ± 30' >120° ± 1°	Check by (校对):	Date (日期):
	Scale (比例): 1:1	Signature by (批准):	Date (日期):
		Revision (版本): A1	Sheet (页数): 1 / 1

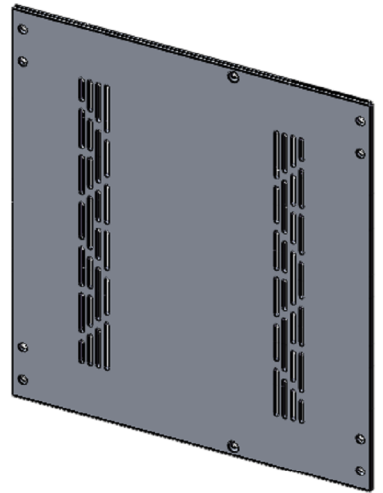
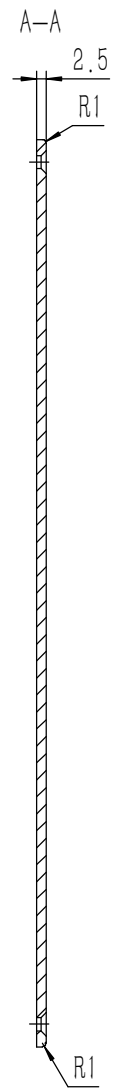
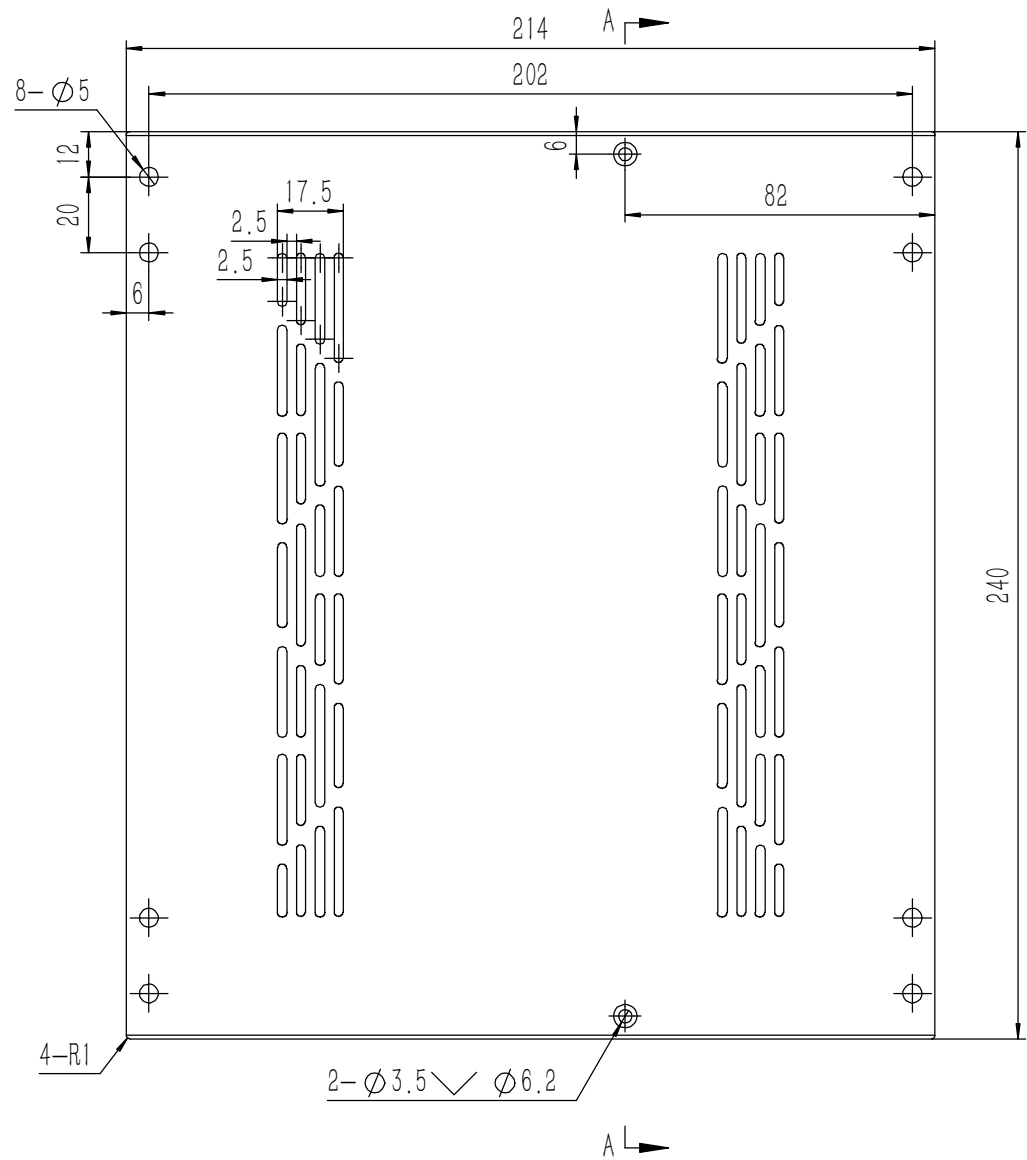

技术要求:  
 1、零件加工表面不应有划痕、擦伤等损伤零件表面的缺陷;  
 2、去除毛刺飞边,锐角倒钝;  
 3、未标注尺寸见3D数模。

Tolerances (未注公差): 0.5 to 6 ± 0.1 6 to 30 ± 0.2 30 to 120 ± 0.3 120 to 400 ± 0.4	Material (材料): 5052-H32 Weight: (重量) (Kg): 0.323 Protection: (表面处理): Part Name (零/部件名称):	YONGU 永固	
Break sharp edges (未注锐边倒角): Ch 0.05 to 0.25 x45°	Angular tolerances (未注角度公差): <6° ± 10' <30° ± 20' <120° ± 30' >120° ± 1°	Part Name (零/部件名称): 上盖板	
Position tolerances (未注位置公差): ±0.05	Drawn by (绘图): 邓展锋	Date (日期): 2020.05.18	Size: (图幅): A2
	Check by (校对):	Date (日期):	Scale (比例): 1:1
	Signature by (批准):	Date (日期):	Revision (版本): A1
			Sheet (页数): 1 / 1

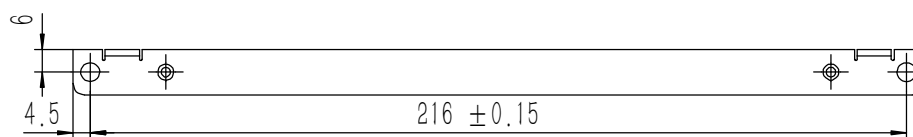
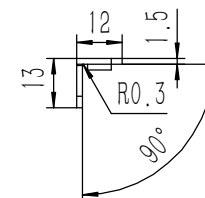
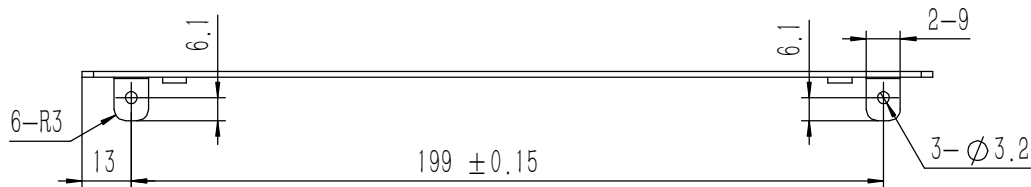
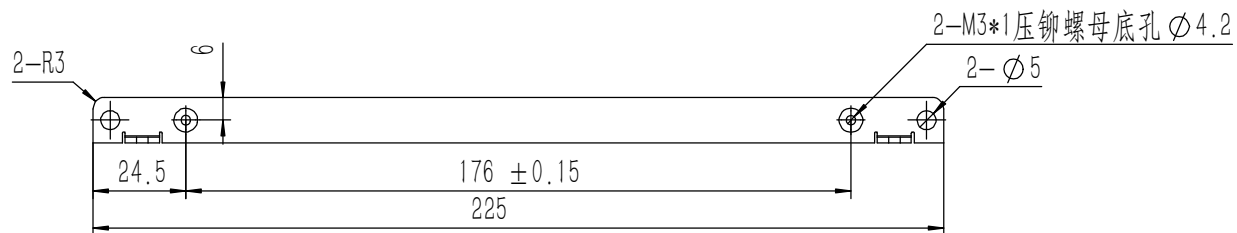

钣金展开及折弯方向参考图 (视图比例1:1)

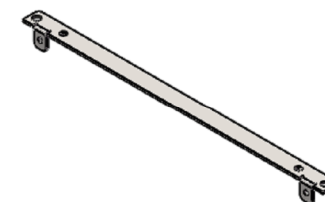
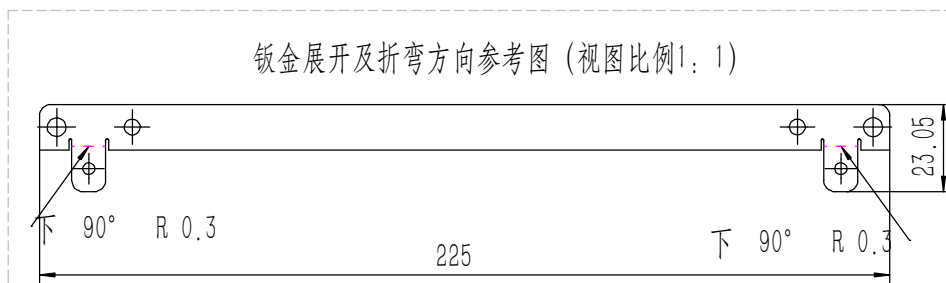

业务代码:

技术要求:

- 1、零件加工表面不应有划痕、擦伤等损伤零件表面的缺陷;
- 2、去除毛刺飞边,锐角倒钝;
- 3、未标注尺寸见3D数模。

Tolerances (未注公差): 0.5 to 6 ± 0.1 6 to 30 ± 0.2 30 to 120 ± 0.3 120 to 400 ± 0.4	Material (材料):	电解板	
	Weight: (重量) (Kg):	0.033	
Break sharp edges (未注锐边倒角): Ch 0.05 to 0.25 x45° Position tolerances (未注位置公差): ±0.05	Protection: (表面处理):	毛坯	
	Angular tolerances (未注角度公差): <6° ± 10' <30° ± 20' <120° ± 30' >120° ± 1°	Part Name (零/部件名称):	面板上固定件1
	Drawing Number (图号):	YG-TY-A10-001	
	Drawn by (绘图):	许宏彬	Date (日期): 2020.09.18
	Check by (校对):		Date (日期):
	Signature by (批准):		Date (日期):
	Size: (图幅):	A2	
	Scale (比例):	1:1	
	Revision (版本):	A1	
	Sheet (页数):	1 / 1	

**YONGU** 永固

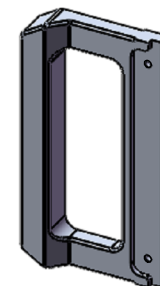
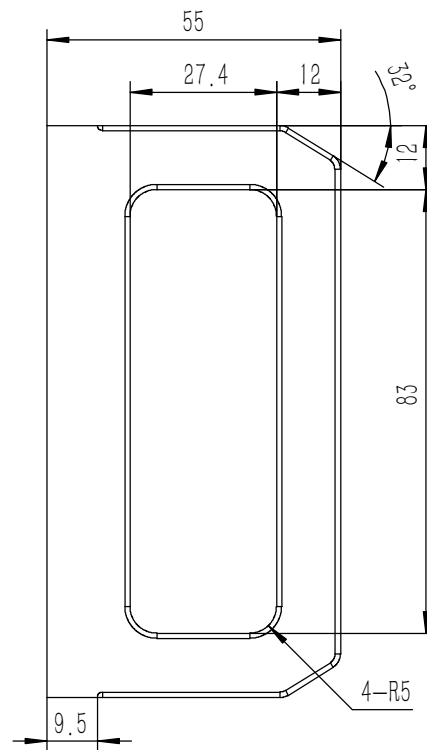
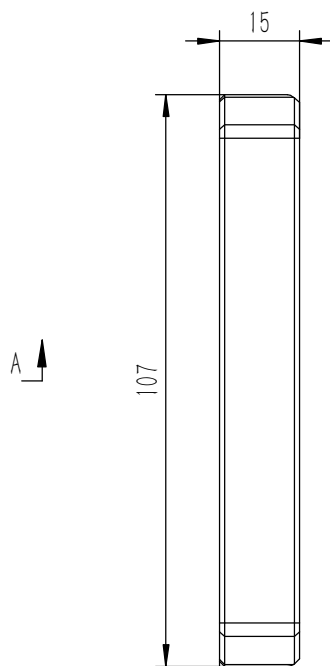
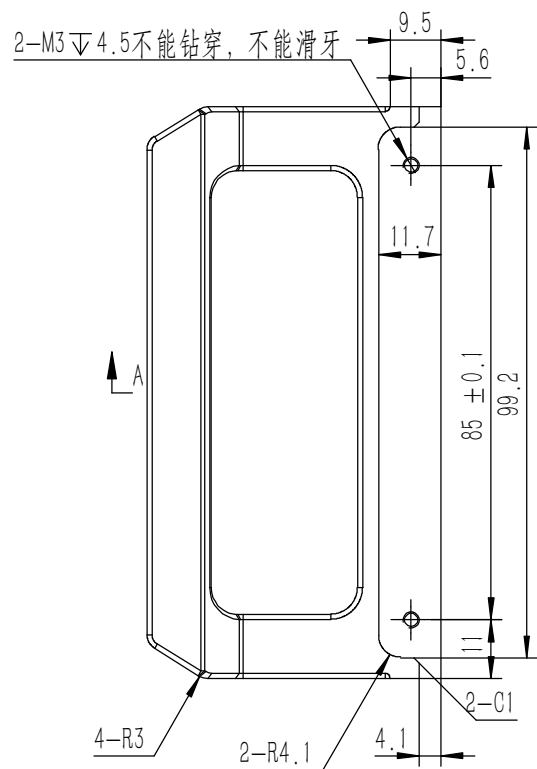
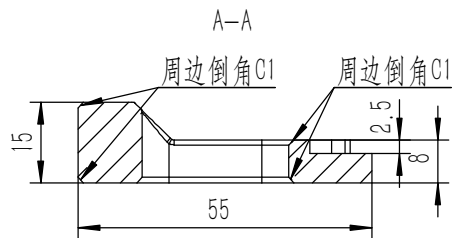

技术要求:

- 1、零件加工表面不应有划痕、擦伤等损伤零件表面的缺陷;
- 2、去除毛刺飞边, 锐角倒钝;
- 3、未标注尺寸见3D数模。

Tolerances (未注公差): 0.5 to 6 ± 0.1 6 to 30 ± 0.2 30 to 120 ± 0.3 120 to 400 ± 0.4	Material (材料):	6063-T5	
	Weight: (重量) (Kg)	0.092	
Break sharp edges (未注锐边倒角): Ch 0.05 to 0.25 x45°	Protection: (表面处理):		
	Part Name (零/部件名称):	拉手-115H	
Position tolerances (未注位置公差): ±0.05	Angular tolerances (未注角度公差): <6° ± 10' <30° ± 20' <120° ± 30' >120° ± 1°	Part Name (零/部件名称):	Drawing Number (图号):
		YONGU 永固	YG-TY-A06-002
	Drawn by (绘图): 邓展锋	Date (日期): 2020.05.18	Size (图幅): A3
	Check by (校对):	Date (日期):	Scale (比例): 1:1
	Signature by (批准):	Date (日期):	Revision (版本): A1
			Sheet (页数): 0 / 0

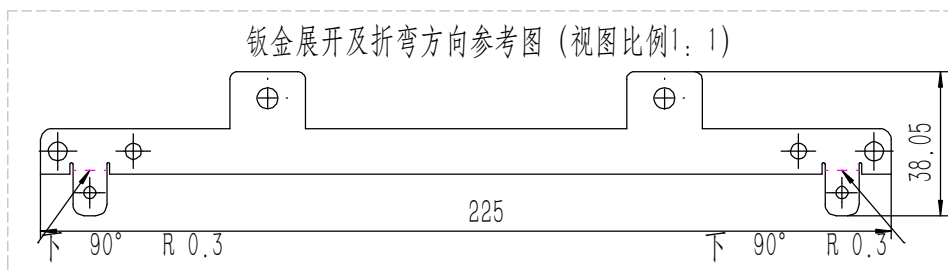
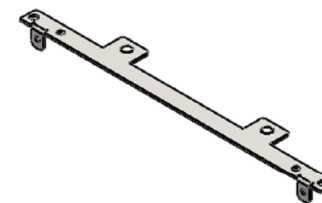
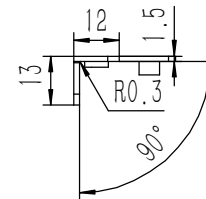
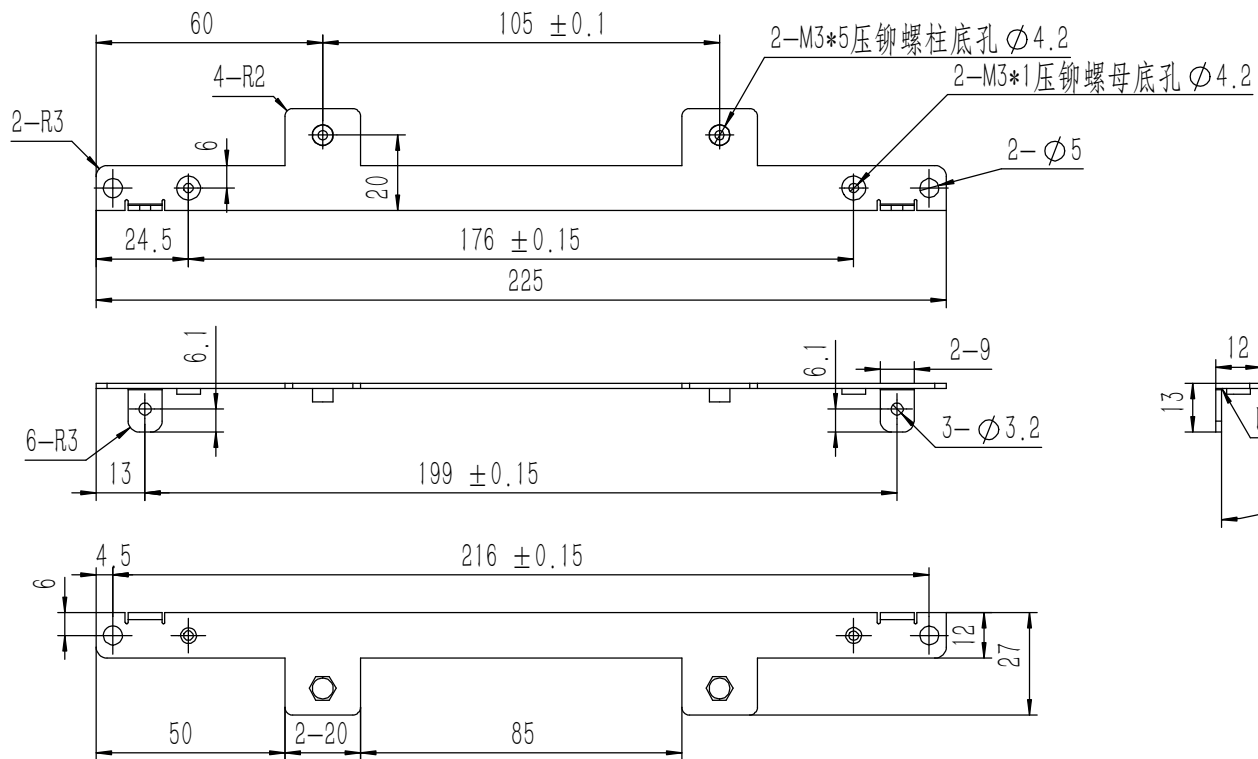

业务代码:

技术要求:

- 1、零件加工表面不应有划痕、擦伤等损伤零件表面的缺陷;
- 2、去除毛刺飞边, 锐角倒钝;
- 3、未标注尺寸见3D数模。

Tolerances (未注公差): 0.5 to 6 ± 0.1 6 to 30 ± 0.2 30 to 120 ± 0.3 120 to 400 ± 0.4	Material (材料): (装配图)	<b>YONGU</b> 永固	Drawing Number (图号): YG-TY-A11-001	
	Weight: (重量) (Kg): 0.041		Size: (图幅): A2	
Break sharp edges (未注锐边倒角): Ch 0.05 to 0.25 x45°	Protection: (表面处理): 毛坯	Part Name (零/部件名称): 面板下固定件1	Sheet (页数): 1 / 1	
	Angular tolerances (未注角度公差): <6° ± 10' <30° ± 20' <120° ± 30' >120° ± 1°		Position tolerances (未注位置公差): ±0.05	Revision (版本): A1
Drawn by (绘图): 许宏彬		Date (日期): 2020.09.18	Signature by (批准):	
Check by (校对):		Date (日期):	Date (日期):	

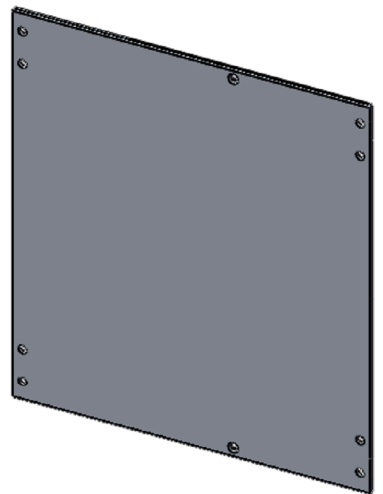
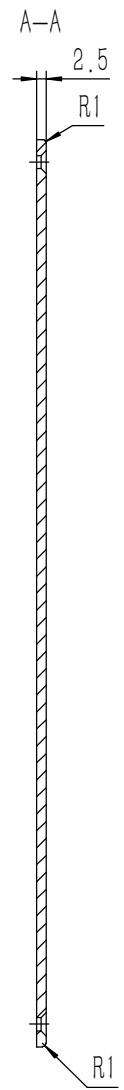
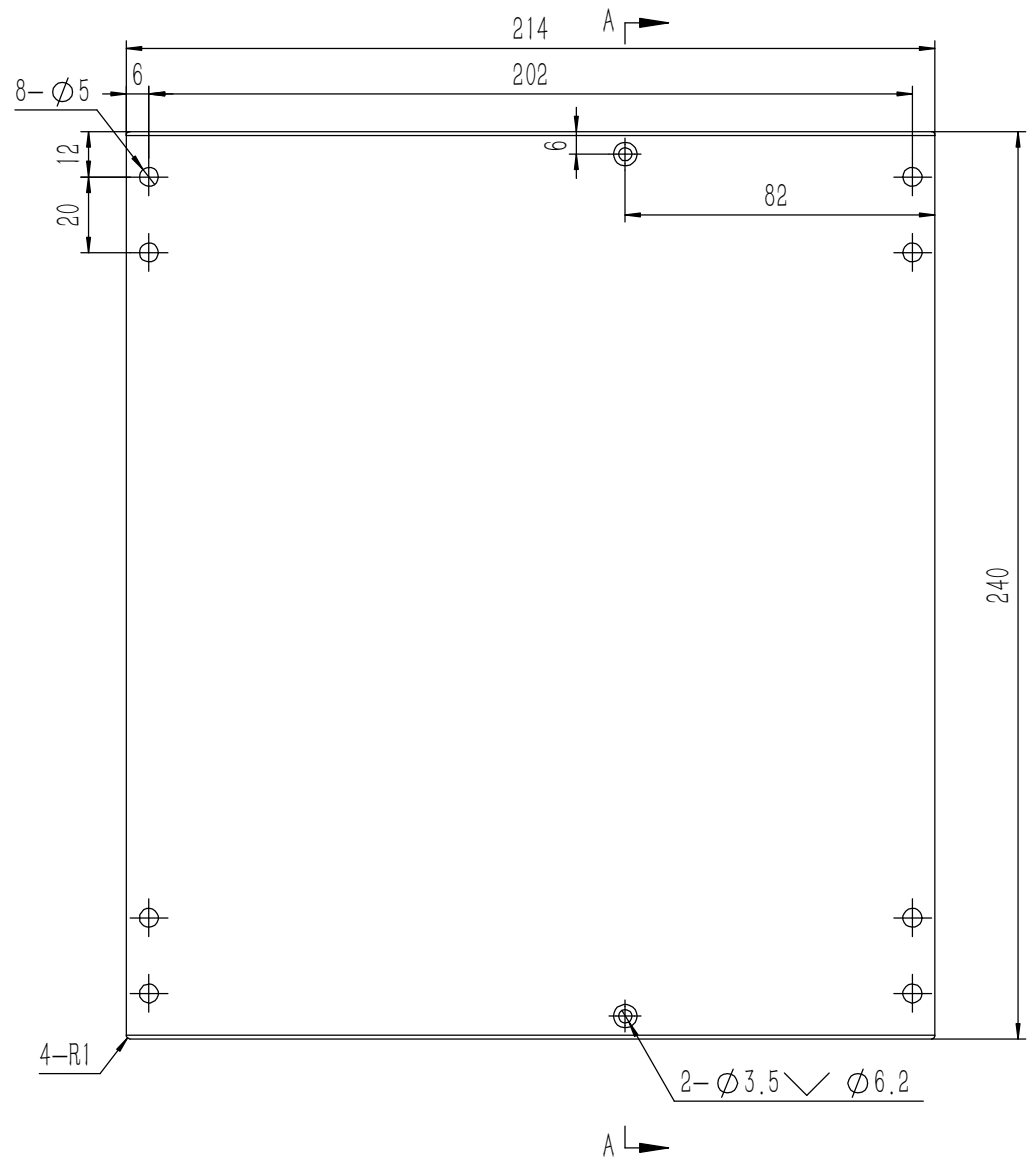

A

Tolerances (未注公差): 0.5 to 6 ± 0.1 6 to 30 ± 0.2 30 to 120 ± 0.3 120 to 400 ± 0.4	Material (材料):	5052-H32	
	Weight: (重量) (Kg):	0.343	
	Protection: (表面处理):		
	Part Name (零/部件名称):	上下盖板	
Break sharp edges (未注锐边倒角): Ch 0.05 to 0.25 x45°	Angular tolerances (未注角度公差): <6° ± 10' <30° ± 20' <120° ± 30' >120° ± 1°	Drawing Number (图号): YG-TY-B01-001	Size: (图幅): A2
Position tolerances (未注位置公差): ±0.05	Drawn by (绘图): 邓展锋	Date (日期): 2020.05.19	Scale (比例): 1:1
	Check by (校对):	Date (日期):	Revision (版本): A1
	Signature by (批准):	Date (日期):	Sheet (页数): 1 / 1



技术要求:  
 1、零件加工表面不应有划痕、擦伤等损伤零件表面的缺陷;  
 2、去除毛刺飞边,锐角倒钝;  
 3、未标注尺寸见3D数模。

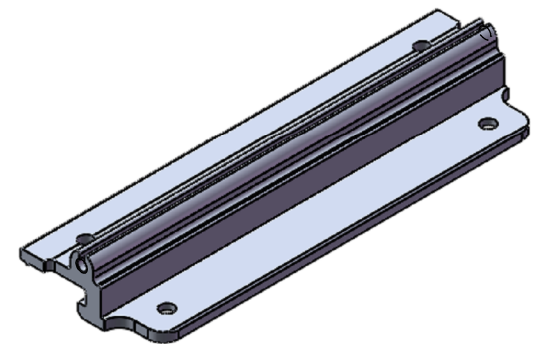
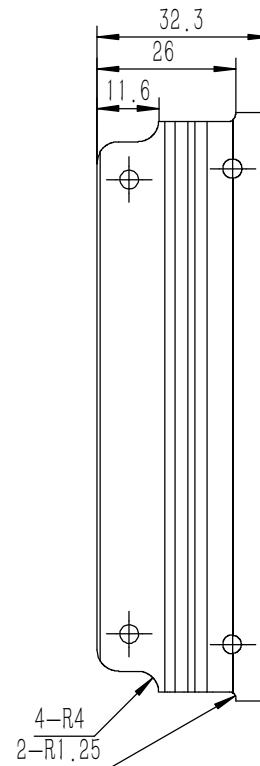
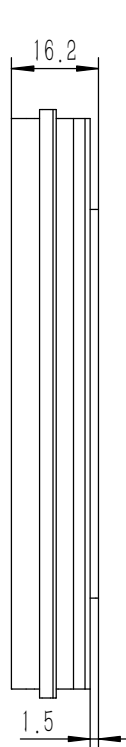
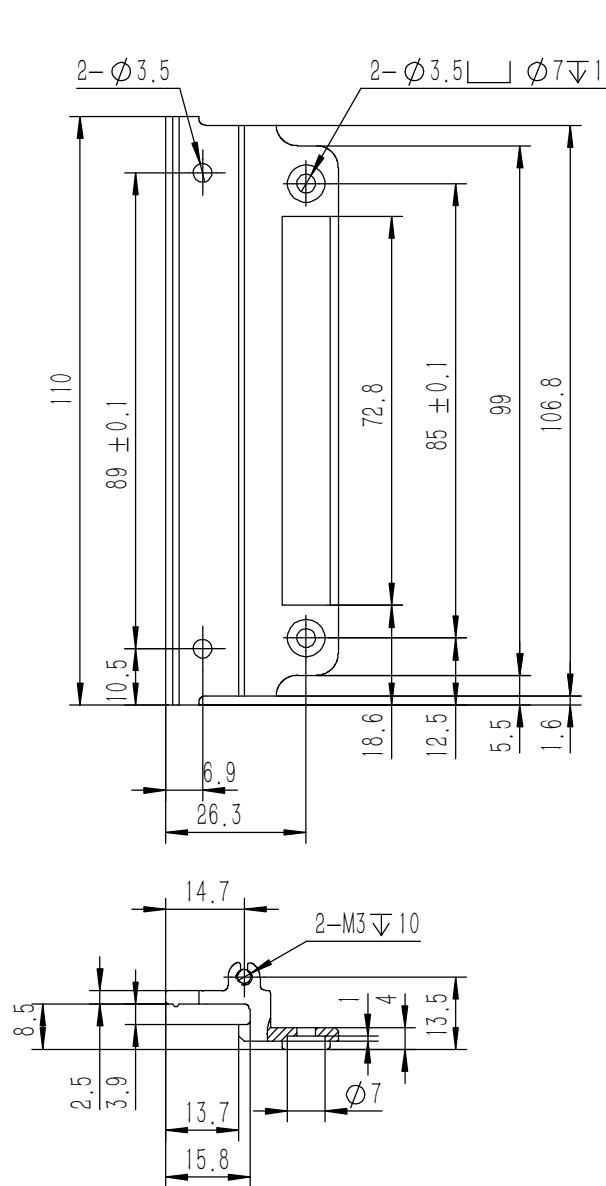

技术要求:

- 1、零件加工表面不应有划痕、擦伤等损伤零件表面的缺陷;
- 2、去除毛刺飞边,锐角倒钝;
- 3、未标注尺寸见3D数模。

Break sharp edges (未注锐边倒角): Ch 0.05 to 0.25 x45°	Angular tolerances (未注角度公差): <6° ± 10' <30° ± 20' <120° ± 30' >120° ± 1°
Position tolerances (未注位置公差): ±0.05	

Tolerances (未注公差): 0.5 to 6 ± 0.1 6 to 30 ± 0.2 30 to 120 ± 0.3 120 to 400 ± 0.4	Material (材料): 6063-T5	YONGU 永固
	Weight: (重量) (Kg) 0.041	
	Protection: (表面处理):	
	Part Name (零/部件名称): A侧板固定件115H	Drawing Number (图号): YG-TY-A08-002
	Drawn by (绘图): 邓展锋	Date (日期): 2020.05.18
	Check by (校对):	Date (日期):
	Signature by (批准):	Date (日期):
	Size (图幅): A3	Sheet (页数): 1 / 1
	Scale (比例): 1:1	Revision (版本): A1



钣金展开及折弯方向参考图 (视图比例1:1)

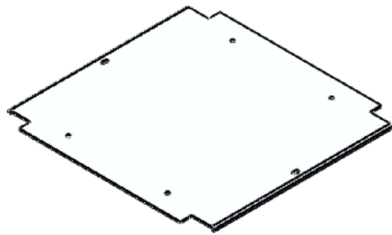
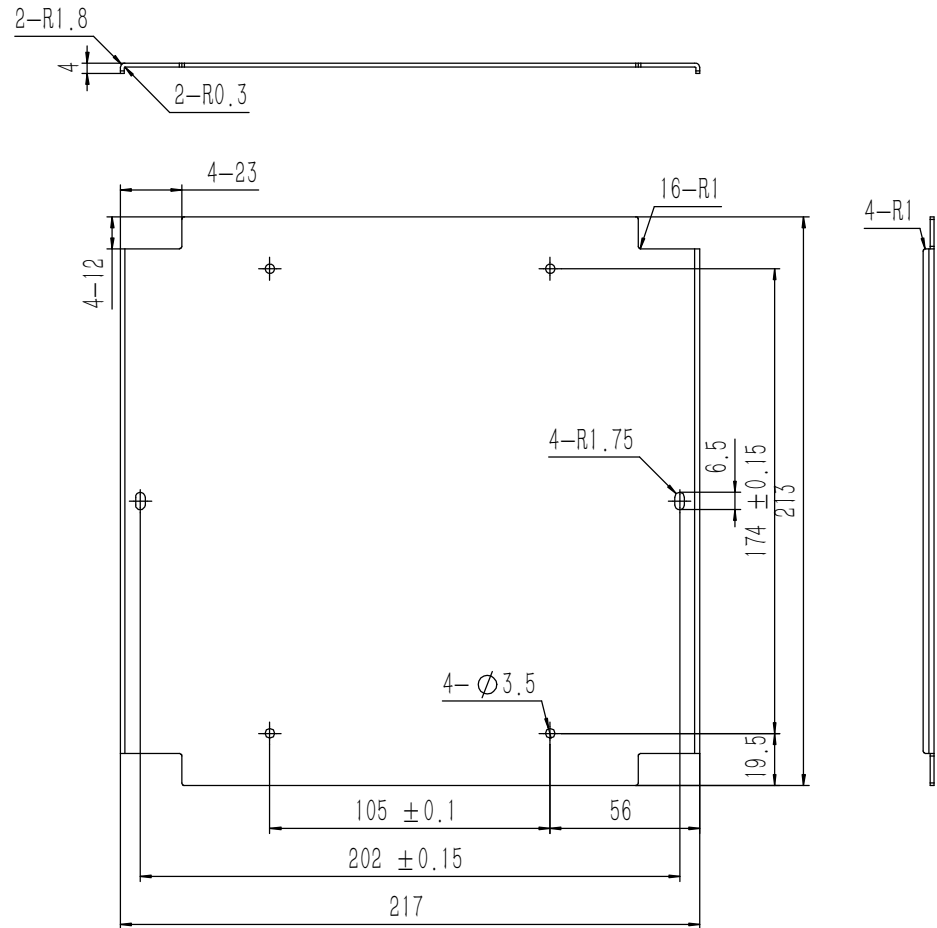
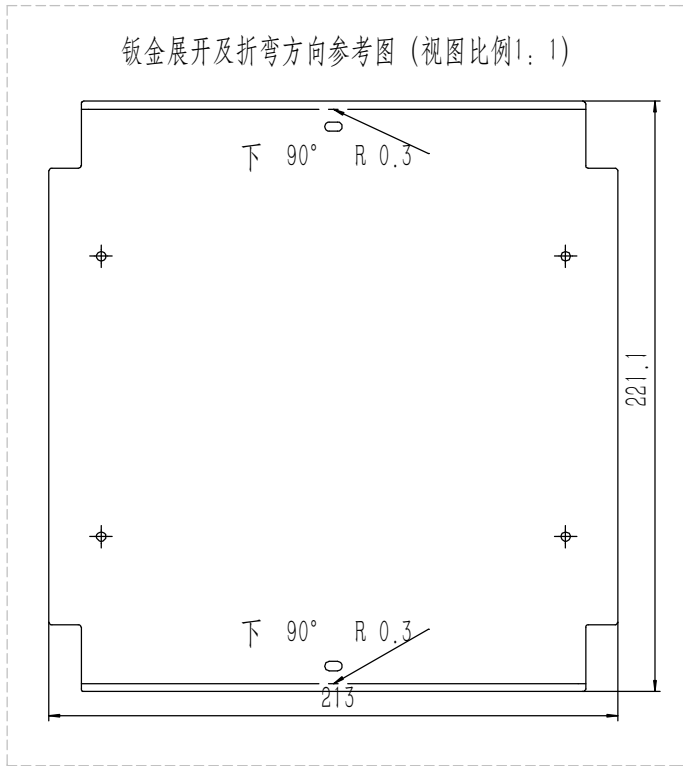

业务代码:

技术要求:

- 1、零件加工表面不应有划痕、擦伤等损伤零件表面的缺陷;
- 2、去除毛刺飞边,锐角倒钝;
- 3、未标注尺寸见3D数模。

Tolerances (未注公差): 0.5 to 6 ± 0.1 6 to 30 ± 0.2 30 to 120 ± 0.3 120 to 400 ± 0.4	Material (材料):	5052-H32	<b>YONGU</b> 永固
	Weight: (重量) (Kg):	0.184	
Break sharp edges (未注锐边倒角): Ch 0.05 to 0.25 x45°	Protection: (表面处理):		Drawing Number (图号): YG-TY-A13-001
Angular tolerances (未注角度公差): <6° ± 10' <30° ± 20' <120° ± 30' >120° ± 1°	Part Name (零/部件名称):	A垫板	
Position tolerances (未注位置公差): ± 0.05	Drawn by (绘图): 许宏彬	Date (日期): 2020.09.17	Size: (图幅): A1
	Check by (校对):	Date (日期):	Scale (比例): 1:1
	Signature by (批准):	Date (日期):	Revision (版本): A1
			Sheet (页数): 1 / 1

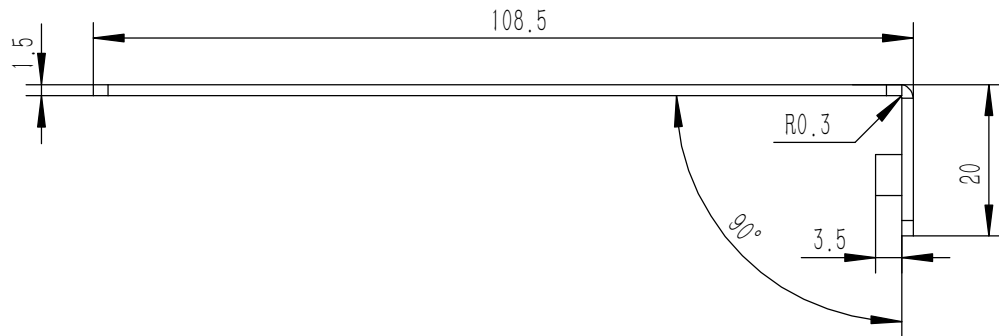
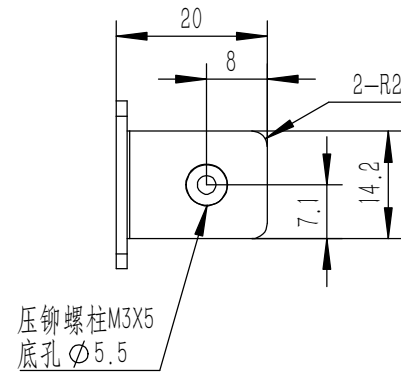
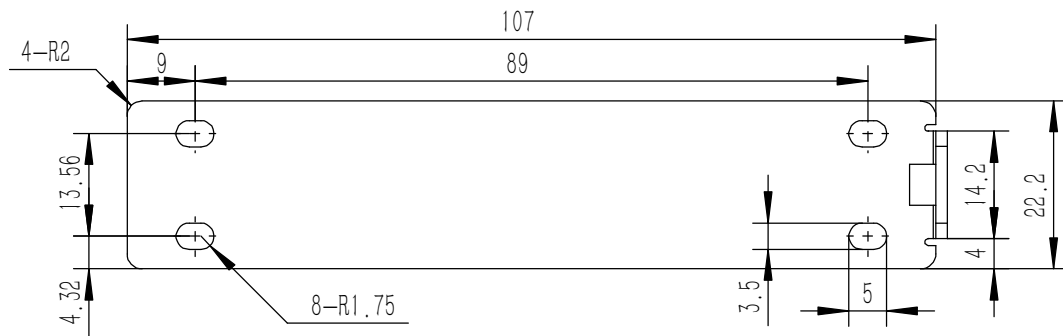

钣金展开及折弯方向参考图 (视图比例1:1)

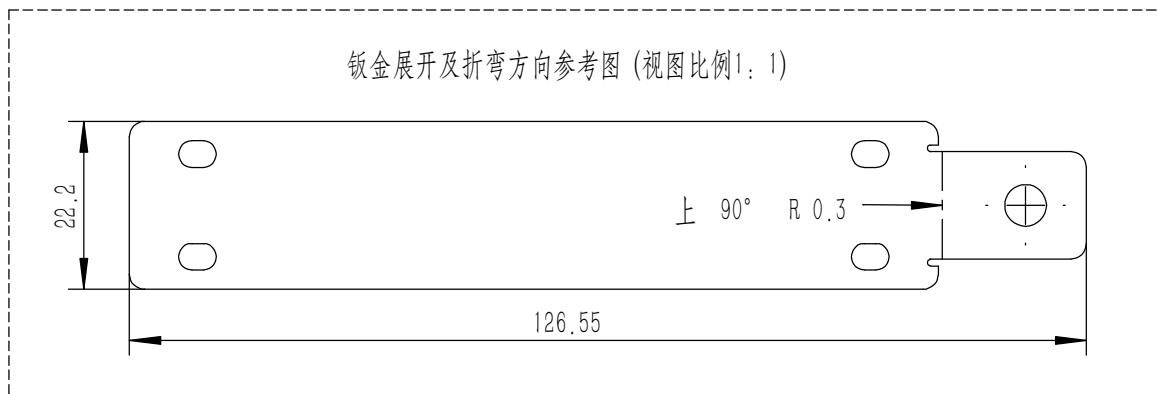

- 技术要求:
- 1、零件加工表面不应有划痕、擦伤等损伤零件表面的缺陷;
  - 2、去除毛刺飞边, 锐角倒钝;
  - 3、未标注尺寸见3D数模。

Tolerances (未注公差): 0.5 to 6 ± 0.1 6 to 30 ± 0.2 30 to 120 ± 0.3 120 to 400 ± 0.4	Material (材料):	电解板	
	Weight: (重量) (Kg)	0.031	
Break sharp edges (未注锐边倒角): Ch 0.05 to 0.25 x45°	Protection: (表面处理):		
	Position tolerances (未注位置公差): ±0.05	Part Name (零/部件名称):	侧板连接件 115H
Angular tolerances (未注角度公差): <6° ± 10' <30° ± 20' <120° ± 30' >120° ± 1°	Drawn by (绘图):	莫永康	Date (日期): 2020.05.19
		Check by (校对):	Date (日期):
	Signature by (批准):	Date (日期):	Drawing Number (图号): YG-TY-A09-002
		Scale (比例): 1:1	Sheet (页数): 1 / 1
		Revision (版本): A1	

**YONGU** 永固

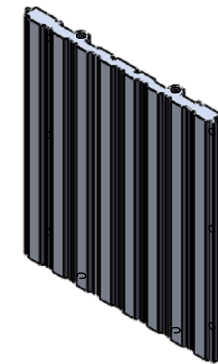
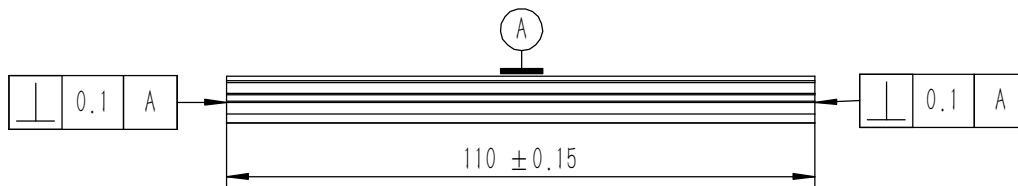
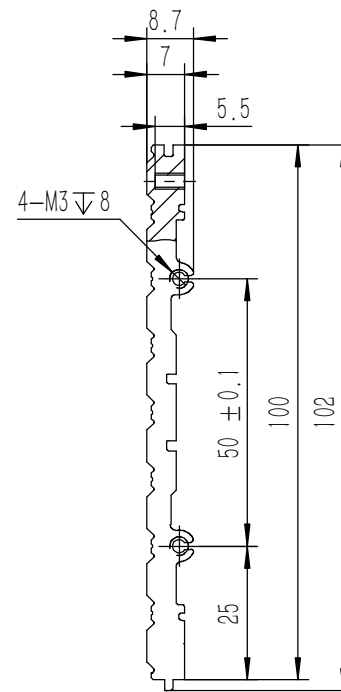
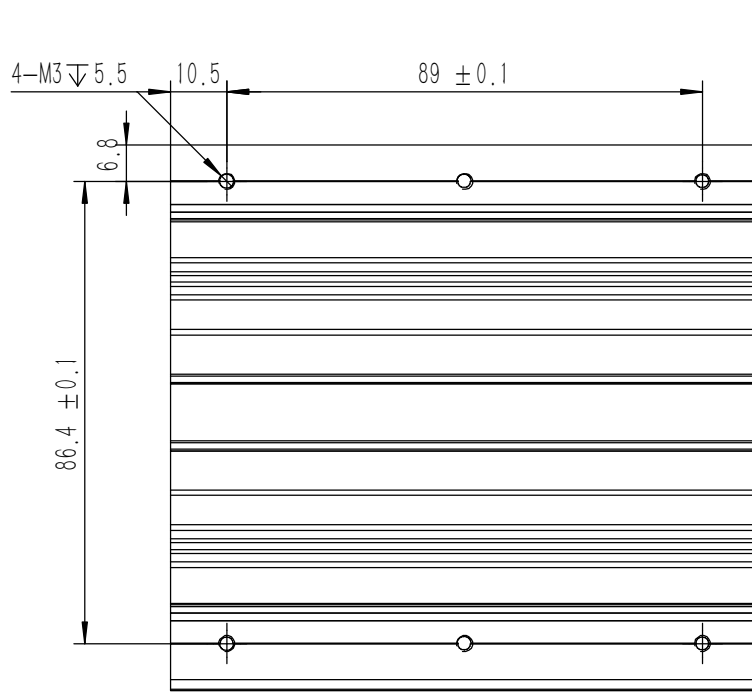

技术要求:

- 1、零件加工表面不应有划痕、擦伤等损伤零件表面的缺陷;
- 2、去除毛刺飞边, 锐角倒钝;
- 3、未标注尺寸见3D数模。

Tolerances (未注公差): 0.5 to 6 ± 0.1 6 to 30 ± 0.2 30 to 120 ± 0.3 120 to 400 ± 0.4	Material (材料):	6063-T5		<b>YONGU</b> 永固
	Weight: (重量) (Kg)	0.161		
Break sharp edges (未注锐边倒角): Ch 0.05 to 0.25 x45°	Protection: (表面处理):			Drawing Number (图号): YG-TY-B03-002
	Position tolerances (未注位置公差): ±0.05	Part Name (零/部件名称):	B组合侧板	
Angular tolerances (未注角度公差): <6° ± 10' <30° ± 20' <120° ± 30' >120° ± 1°	Drawn by (绘图): 邓展锋	Date (日期): 2020.05.19	Size (图幅): A3	Sheet (页数): 1 / 1
	Check by (校对):	Date (日期):	Scale (比例): 1:1	
	Signature by (批准):	Date (日期):	Revision (版本): A1	

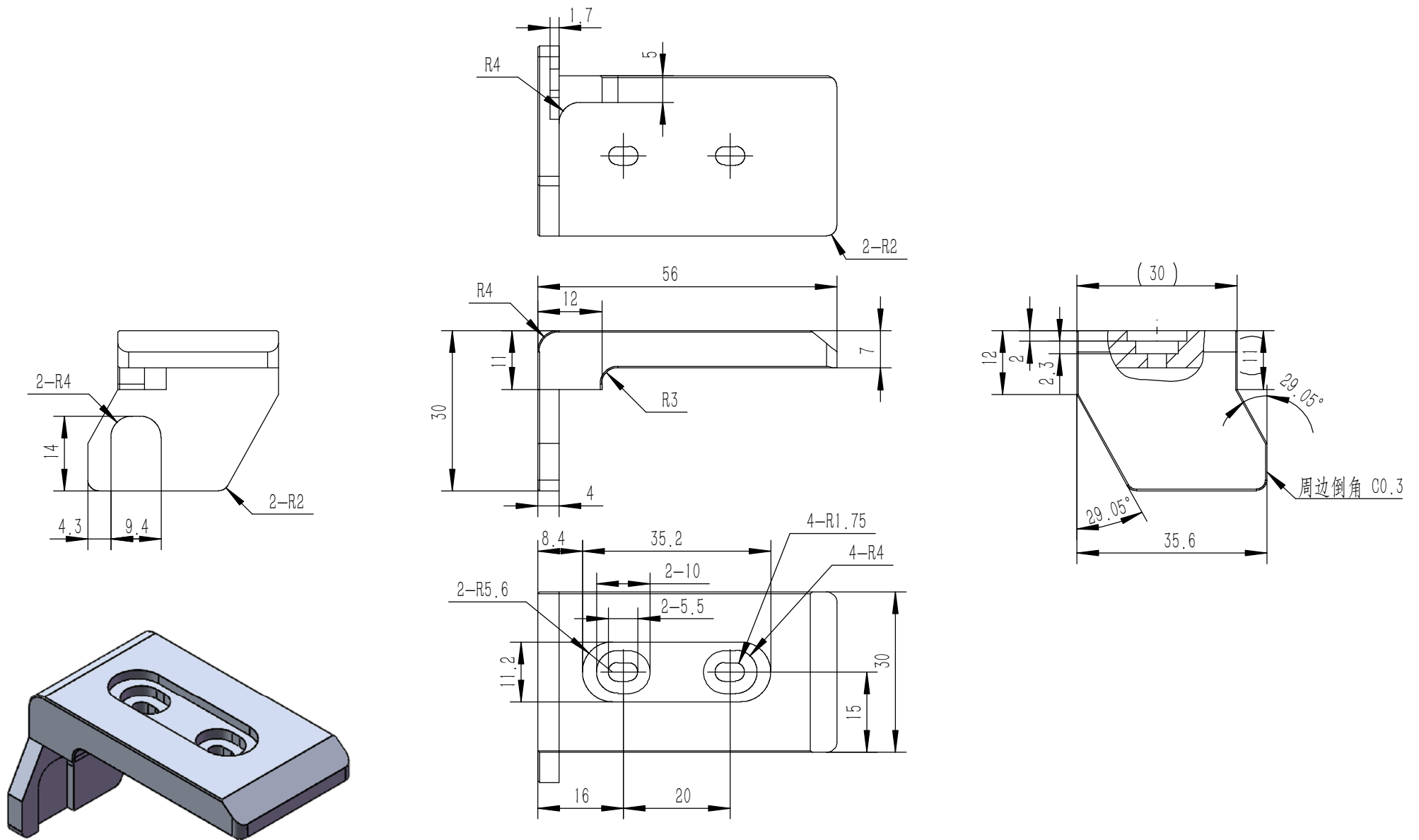

技术要求:  
 1、零件加工表面不应有划痕、擦伤等损伤零件表面的缺陷;  
 2、去除毛刺飞边,锐角倒钝;  
 3、未标注尺寸见3D数模。

Tolerances (未注公差): 0.5 to 6 ± 0.1 6 to 30 ± 0.2 30 to 120 ± 0.3 120 to 400 ± 0.4	Material (材料):	6063-T5	
	Weight: (重量) (Kg)	0.035	
Break sharp edges (未注锐边倒角): Ch 0.05 to 0.25 x45°	Protection: (表面处理):		
	Part Name (零/部件名称):	B包角1	
Position tolerances (未注位置公差): ±0.05	Angular tolerances (未注角度公差): <6° ± 10' <30° ± 20' <120° ± 30' >120° ± 1°	Part Name (零/部件名称):	B包角1
	Drawing Number (图号):	YG-TY-B05-001	
Drawn by (绘图):	Date (日期):	2020.05.18	Size: (图幅): A4
Check by (校对):	Date (日期):		Scale (比例): 1:1
Signature by (批准):	Date (日期):		Revision (版本): A1
			Sheet (页数): 1 / 1



2-M3 4.5不能钻穿，不能滑牙

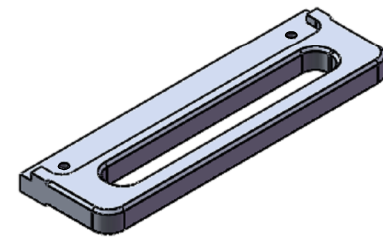
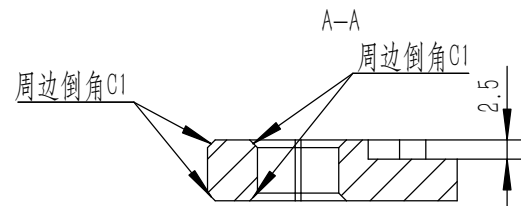
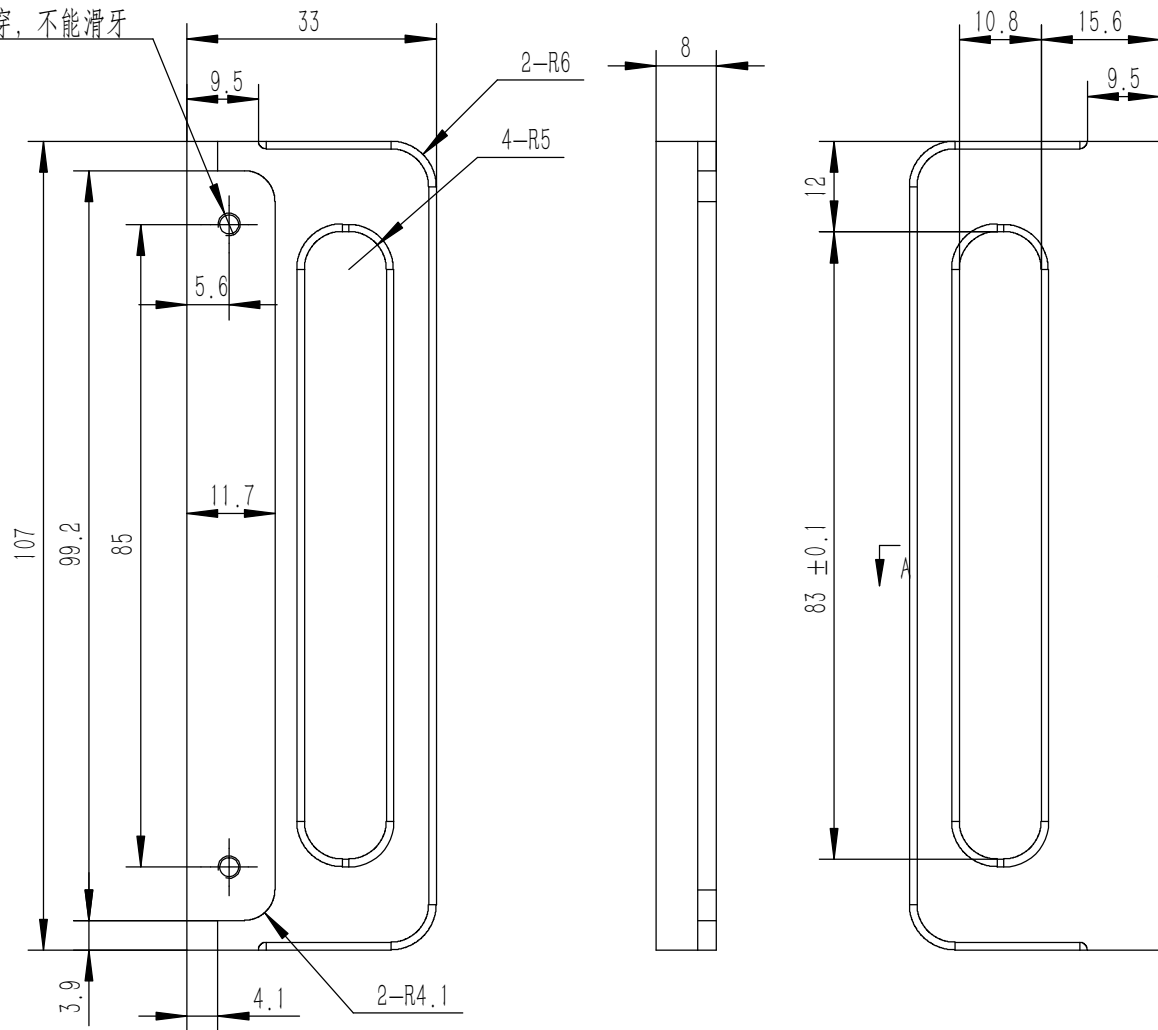

技术要求:

- 1、零件加工表面不应有划痕、擦伤等损伤零件表面的缺陷;
- 2、去除毛刺飞边，锐角倒钝;
- 3、未标注尺寸见3D数模。

Tolerances (未注公差): 0.5 to 6 ± 0.1 6 to 30 ± 0.2 30 to 120 ± 0.3 120 to 400 ± 0.4	Material (材料):	5052-H32		
	Weight: (重量) (Kg)	0.048		
	Protection: (表面处理):			
	Part Name (零/部件名称):	后防护条-115H		
Break sharp edges (未注锐边倒角): Ch 0.05 to 0.25 x45°	Angular tolerances (未注角度公差): <6° ± 10' <30° ± 20' <120° ± 30' >120° ± 1°	Drawing Number (图号): YG-TY-A07-002		
		Drawn by (绘图): 邓展锋		Date (日期): 2020.05.18
Position tolerances (未注位置公差): ±0.05	Check by (校对):	Date (日期):	Scale (比例): 1:1	Sheet (页数): 1 / 1
	Signature by (批准):	Date (日期):	Revision (版本): A1	

**YONGU** 永固

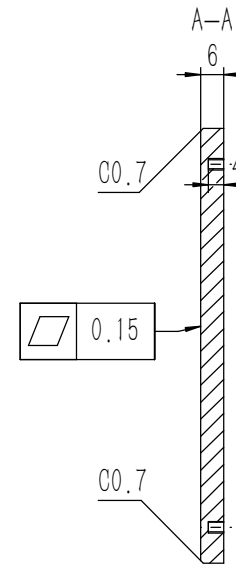
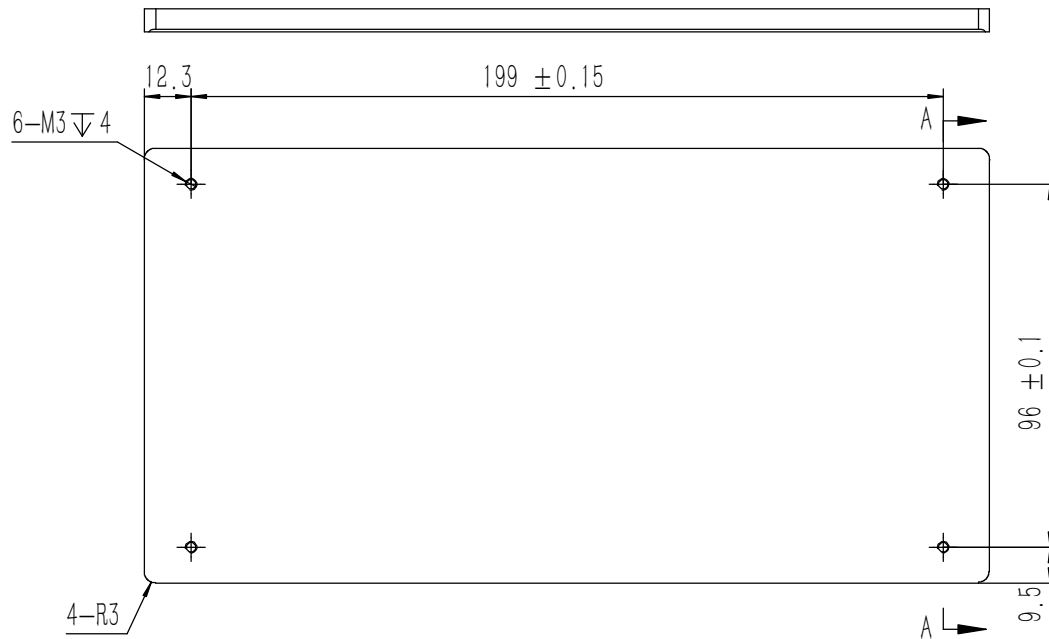
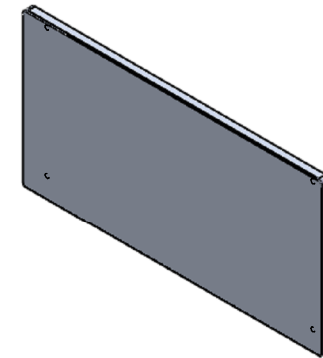
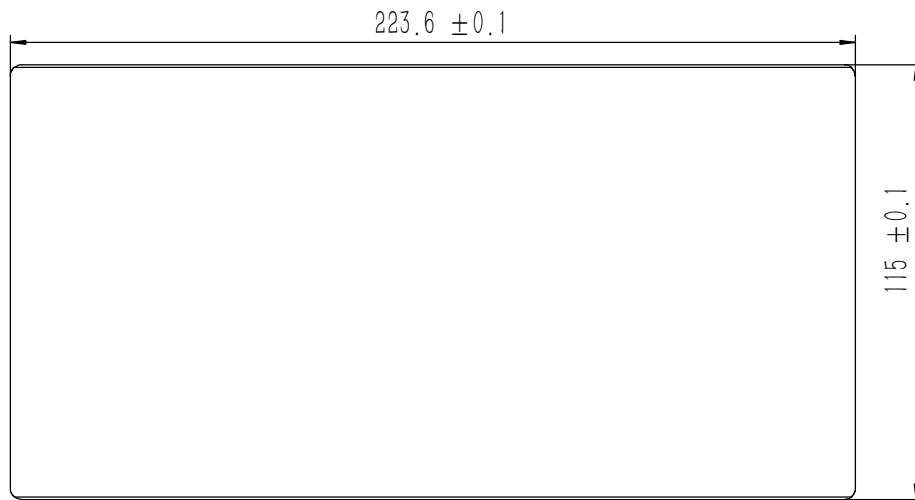

- 技术要求:
- 1、零件加工表面不应有划痕、擦伤等损伤零件表面的缺陷;
  - 2、去除毛刺飞边,锐角倒钝;
  - 3、未标注尺寸见3D数模。

Tolerances (未注公差):	Material (材料):	5052-H32	
	0.5 to 6 ± 0.1	Weight: (重量) (Kg):	0.413
6 to 30 ± 0.2	Protection: (表面处理):		
30 to 120 ± 0.3	Part Name (零/部件名称):	前后面板-115H	
120 to 400 ± 0.4	Part Name (零/部件名称):	前后面板-115H	
Break sharp edges (未注锐边倒角): Ch 0.05 to 0.25 x45°	Angular tolerances (未注角度公差):	Drawn by (绘图):	Date (日期): 2020.05.18
Position tolerances (未注位置公差): ±0.05	<6° ± 10' <30° ± 20' <120° ± 30' >120° ± 1°	Check by (校对):	Date (日期):
		Signature by (批准):	Date (日期):
			Size: (图幅): A2
			Scale (比例): 1:1
			Revision (版本): A1
			Sheet (页数): 1 / 1

**YONGU** 永固

Drawing Number (图号): YG-TY-A12-002