

序号	图号	名称	材料	数量	单重	备注
25	YG-D01-0000-005	组合侧板	6063-T5	2	0.067	
24	YG-TY-ZSJ-001	螺丝装饰件 M3	5052-H32	8	0.000	
23	YG-D01-0000-006	组合侧板	6063-T5	2	0.163	
22	YG-D01-0000-007	组合侧板	6063-T5	2	0.078	
21	YG-TY-LMT-002	塑料螺母套 M3	ABS	14	0.0001	
20	GB-T-973-1976-C-NI-M3X14	碳钢镀镍十字大扁头螺丝M3X14	普通碳钢	8	0.001	
19	GB-T-819.1-2000-C-NI-M3X6	碳钢镀镍十字沉头螺丝M3X6	普通碳钢	28	0.0004	
18	YG-D01-0000-004	D安装垫板	申解板	1	0.523	
17	YG-D01-0000-001	前后面板	5052-H32	2	0.268	
16	YG-D01-0000-008	D拉手	6063-T5	2	0.084	
15	GB-T-70.1-2000-S-NL-M3X8	不锈钢内六角杯头螺丝M3X8	SUS 304	16	0.001	
14	GB-T-70.3-2000-C-NI-M3X8	芳生镀白镍内六角沉头螺丝M3X8	普通碳钢	8	0.0004	
13	GB-T-39-1988-C-ZI-M3	方螺母镀白锌M3	普通碳钢	14	0.0004	
12	YG-D01-0000-009	D后防护	6063-T5	2	0.050	
11	S-M3-1-ZI	压铆螺母镀白锌M3X1	普通碳钢	8	0.3750	
10	YG-TY-JJ-003	D后机脚	6063-T5	2	0.028	
9	YG-D01-0000-011	D中间横梁	6063-T5	1	0.093	
8	YG-D01-0000-003	下盖板	5052-H32	1	0.261	
7	YG-TY-JJ-002	D活动机脚	6063-T5	2	0.017	
6	YG-TY-GZ-001	钢珠 D4.7	普通碳钢	2	0.0004	
5	YG-TY-JJ-001	D前机脚座	6063-T5	2	0.023	
4	YG-TY-TH-001	弹簧 0.6X4X20	普通碳钢	2	0.000	
3	GB-T-80-2007-S-NL-M6X10	不锈钢内六角凹端紧定螺钉M6X10	普通碳钢	2	0.0019	
2	YG-D01-0000-010	D前后横梁	6063-T5	4	0.150	
1	YG-D01-0000-002	上盖板	5052-H32	1	0.262	

- 技术要求:
- 1、必须按照设计、工艺要求及本规定和有关标准进行装配;
 - 2、所有零部件(包括外购、外协件)必须具有检验合格证方能进行装配;
 - 3、零件在装配前必须清理和清洗干净,不得有毛刺、飞边、氧化皮、锈蚀、切屑、砂粒、灰尘和油污等,并应符合相应清洁度要求;
 - 4、装配过程中零件不得磕碰、划伤和锈蚀;
 - 5、油漆未干的零件不得进行装配;
 - 6、相对运动的零件,装配时接触面间应加润滑油脂;
 - 7、各零、部件装配后相对位置应准确。

Tolerances (未注公差): 0.5 to 6 ± 0.1 6 to 30 ± 0.2 30 to 120 ± 0.3 120 to 400 ± 0.4	Material (材料):	(装配图)	<h1>YONGGU 永固</h1>
	Weight: (重量) (Kg):	3.353	
Break sharp edges (未注锐边倒角): Ch 0.05 to 0.25 x45°	Protection: (表面处理):		Drawing Number (图号): YG-D01-0000-000
Position tolerances (未注位置公差): ± 0.05	Part Name (零/部件名称):	D01机箱	
Angular tolerances (未注角度公差): <6° ± 10' <30° ± 20' <120° ± 30' >120° ± 1°	Drawn by (绘图): 邓展锋 Date (日期): 2020.05.23	Date (日期): Date (日期):	Size (图幅): A0 Scale (比例): 1:1 Revision (版本): A1
	Check by (校对): Signature by (批准):	Date (日期): Date (日期):	Sheet (页数): 1 / 1

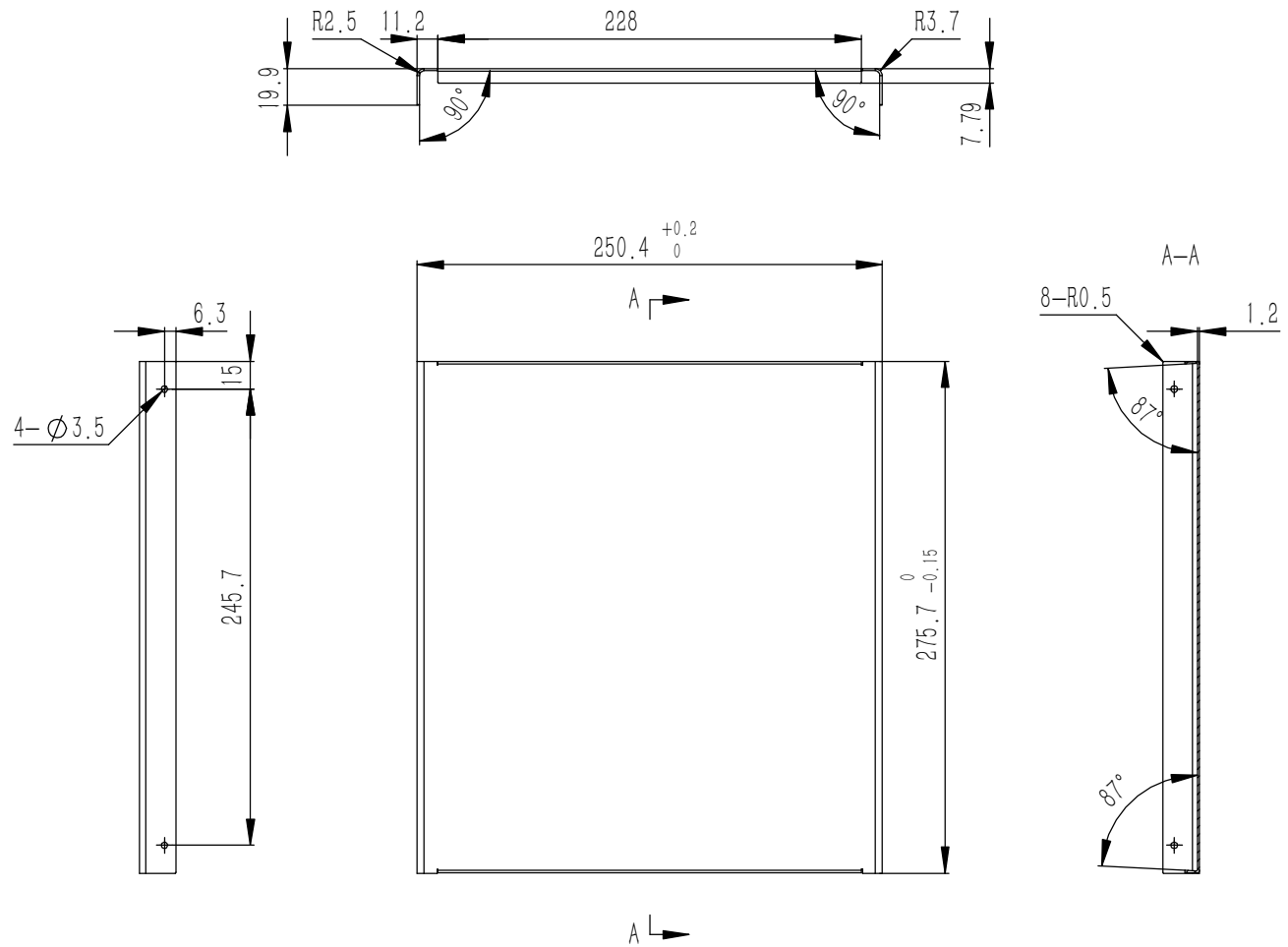
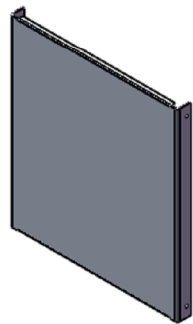
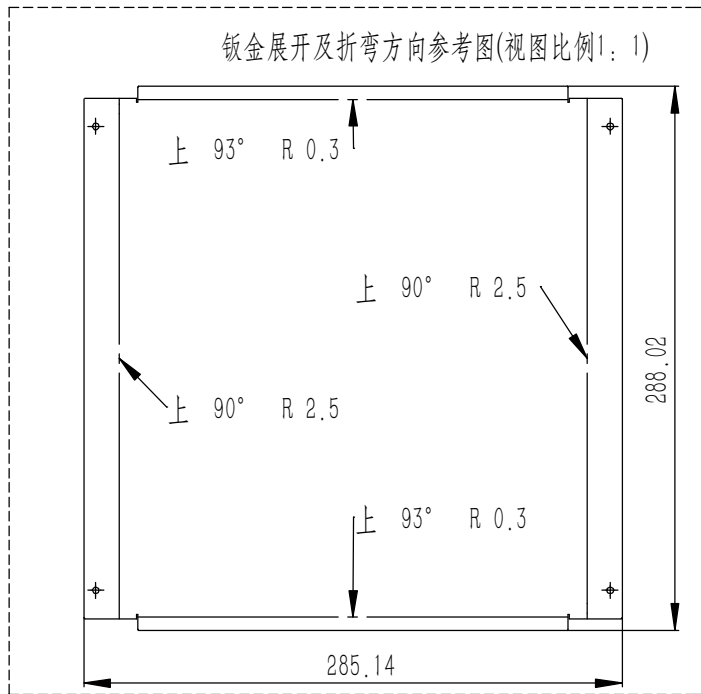

- 技术要求:
- 1、零件加工表面不应有划痕、擦伤等损伤零件表面的缺陷;
 - 2、去除毛刺飞边,锐角倒钝;
 - 3、未标注尺寸见3D数模。

Break sharp edges (未注锐边倒角): Ch 0.05 to 0.25 x45°	Angular tolerances (未注角度公差): <6° ± 10' <30° ± 20' <120° ± 30' >120° ± 1°
Position tolerances (未注位置公差): ±0.05	

Tolerances (未注公差): 0.5 to 6 ± 0.1 6 to 30 ± 0.2 30 to 120 ± 0.3 120 to 400 ± 0.4	Material (材料): 5052-H32	YONGU 永固
Weight: (重量) (Kg): 0.262	Weight: (重量) (Kg): 0.262	
Protection: (表面处理):	Protection: (表面处理):	
Part Name (零/部件名称):	Part Name (零/部件名称): 上盖板	Drawing Number (图号): YG-D01-0000-002
Drawn by (绘图): 莫永康	Date (日期): 2020.05.22	Size (图幅): A0
Check by (校对):	Date (日期):	Scale (比例): 1:1
Signature by (批准):	Date (日期):	Revision (版本): A1
		Sheet (页数): 1 / 1

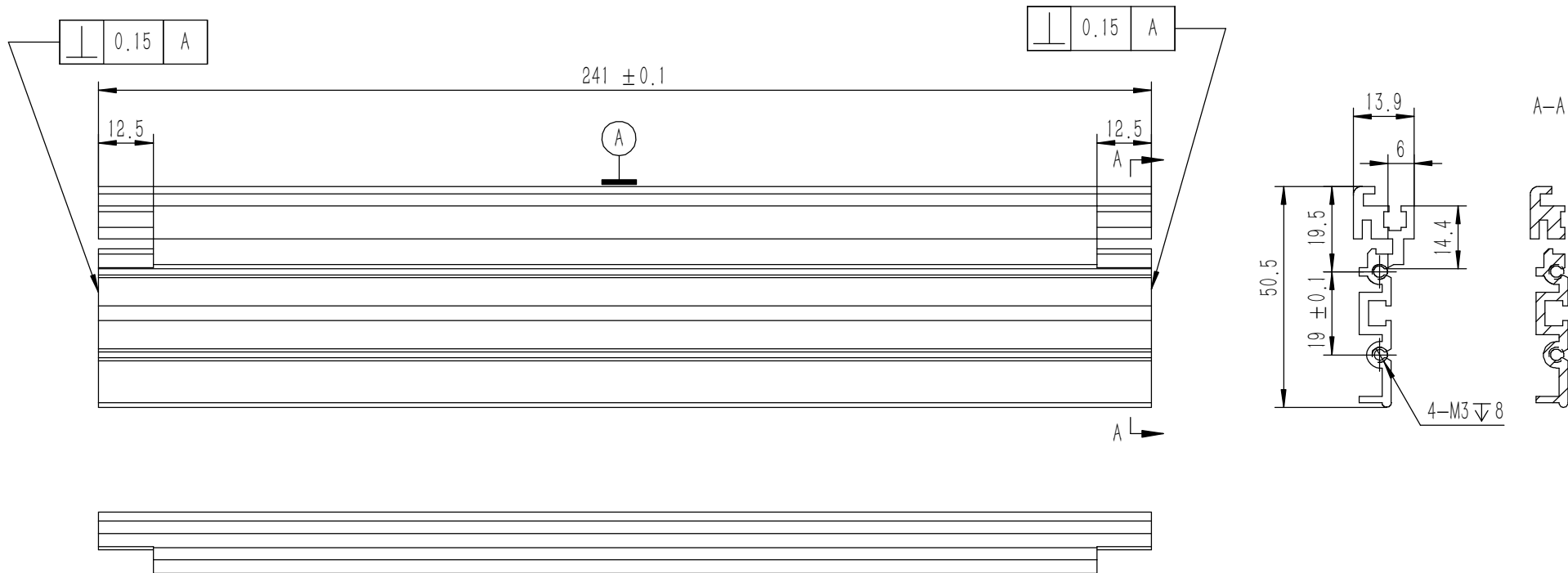

技术要求:

- 1、零件加工表面不应有划痕、擦伤等损伤零件表面的缺陷;
- 2、去除毛刺飞边,锐角倒钝;
- 3、未标注尺寸见3D数模。

Break sharp edges (未注锐边倒角): Ch 0.05 to 0.25 x45°	Angular tolerances (未注角度公差): <6° ± 10' <30° ± 20' <120° ± 30' >120° ± 1°
Position tolerances (未注位置公差): ±0.05	

Tolerances (未注公差): 0.5 to 6 ± 0.1 6 to 30 ± 0.2 30 to 120 ± 0.3 120 to 400 ± 0.4	Material (材料): 6063-T5	YONGU 永固
	Weight: (重量) (Kg) 0.150	
Protection: (表面处理):	Part Name (零/部件名称): D前后横梁	Drawing Number (图号): YG-D01-0000-010
Part Name (零/部件名称):	Drawn by (绘图): 邓展锋	Date (日期): 2020.05.22
	Check by (校对):	Date (日期):
	Signature by (批准):	Date (日期):
	Scale (比例): 1:1	Sheet (页数): 1 / 1
	Revision (版本):	

M6 12底孔 $\phi 5$ 贯穿

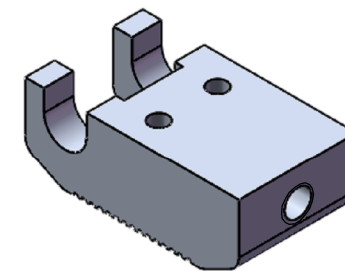
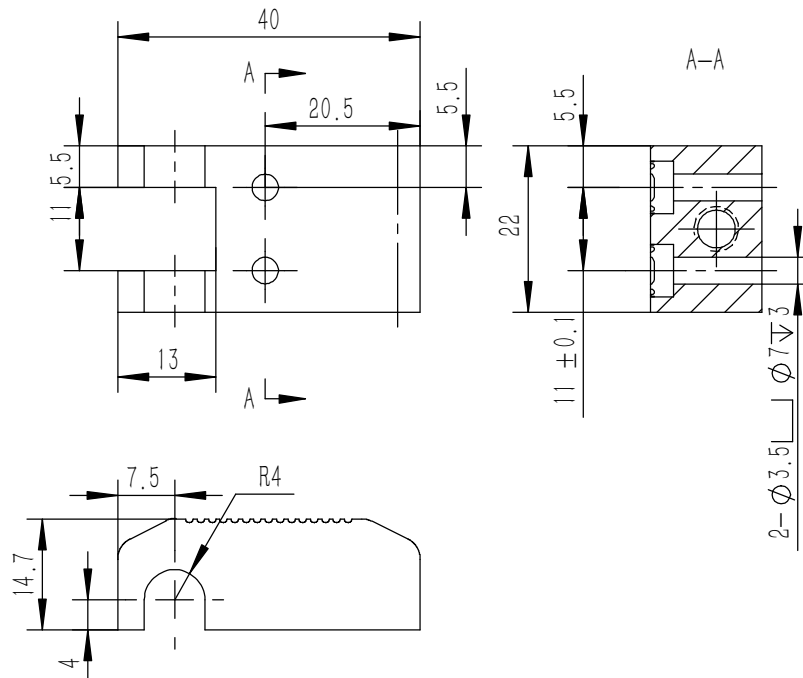
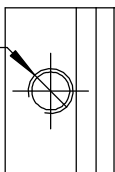

技术要求:

- 1、零件加工表面不应有划痕、擦伤等损伤零件表面的缺陷;
- 2、去除毛刺飞边, 锐角倒钝;
- 3、未标注尺寸见3D数模。

件/套(pcs/set)

Break sharp edges (未注锐边倒角): Ch 0.05 to 0.25 x45°	Angular tolerances (未注角度公差): <6° ± 10' <30° ± 20' <120° ± 30' >120° ± 1°
Position tolerances (未注位置公差): ±0.05	

Tolerances (未注公差): 0.5 to 6 ± 0.1 6 to 30 ± 0.2 30 to 120 ± 0.3 120 to 400 ± 0.4		Material (材料): 6063-T5		
		Weight: (重量) (Kg) 0.023		
		Protection: (表面处理):	Part Name (零/部件名称): D前机脚座	
		Part Name (零/部件名称): D前机脚座	Drawing Number (图号): YG-TY-JJ-001	
		Drawn by (绘图): 邓展锋	Date (日期): 2020.05.22	Size: (图幅): A4
		Check by (校对):	Date (日期):	Scale (比例): 1:1
		Signature by (批准):	Date (日期):	Revision (版本): 1 / 1

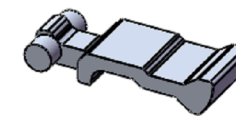
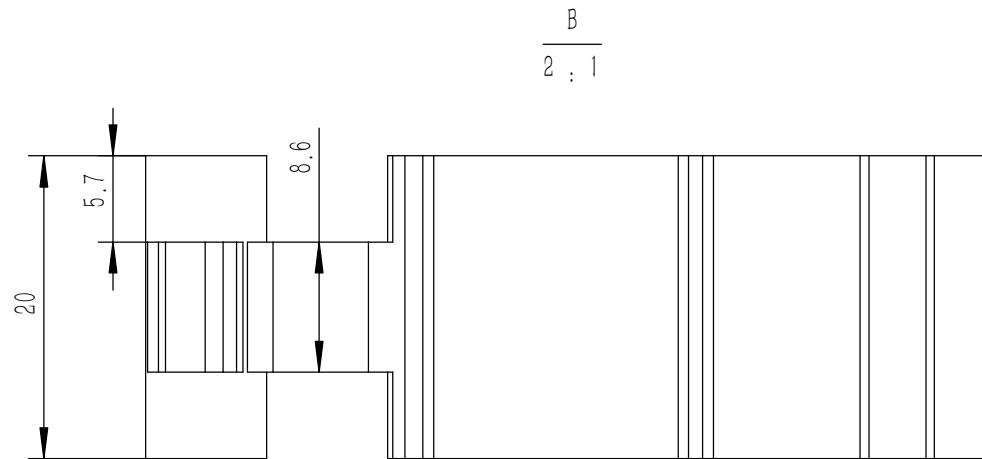
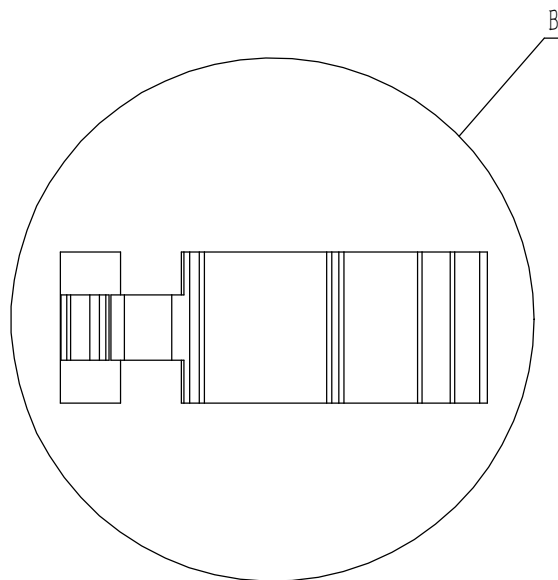
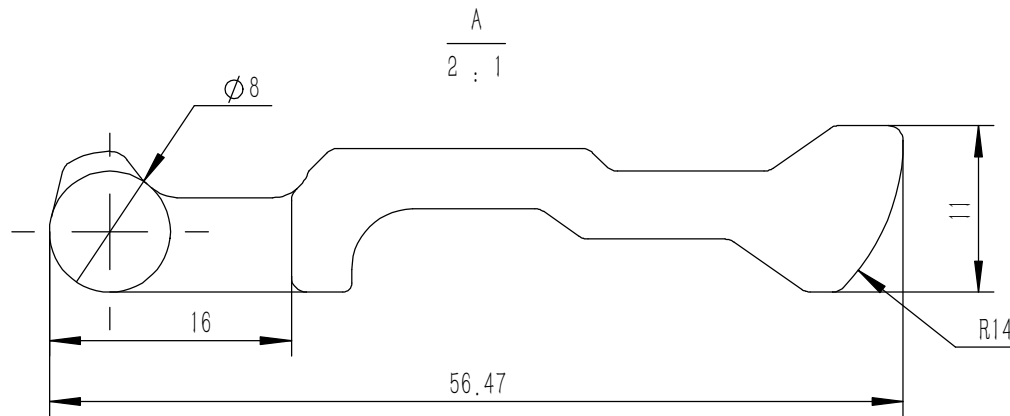
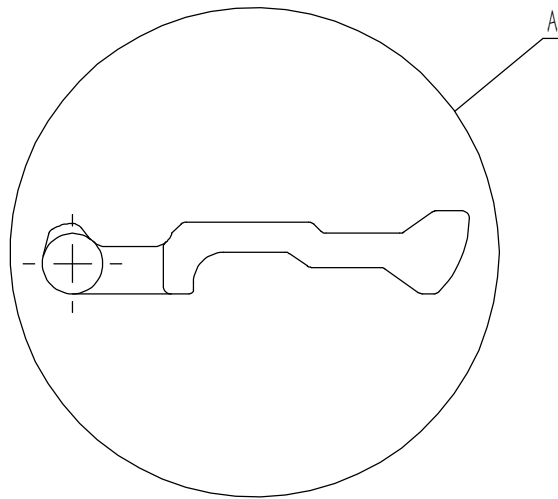

件/套(pcs/set)

Tolerances (未注公差):	0.5 to 6	± 0.1	Material (材料): 6063-T5	Weight: (重量) (Kg) 0.017	Protection: (表面处理):	Part Name (零/部件名称):	Drawing Number (图号):	YONGU 永固
	6 to 30	± 0.2						
30 to 120	± 0.3							
120 to 400	± 0.4							
Break sharp edges (未注锐边倒角): Ch 0.05 to 0.25 x45°	Angular tolerances (未注角度公差):	<6° ± 10'	D活动机脚		Date (日期): 2020.05.22		Scale (图幅): A4	
Position tolerances (未注位置公差): ± 0.05	<30° ± 20'	<120° ± 30'	Drawn by (绘图): 邓展锋	Date (日期):	Scale (比例): 1:1	Sheet (页数):		
	>120° ± 1°		Check by (校对):	Date (日期):	Revision (版本):	1 / 1		
			Signature by (批准):	Date (日期):				

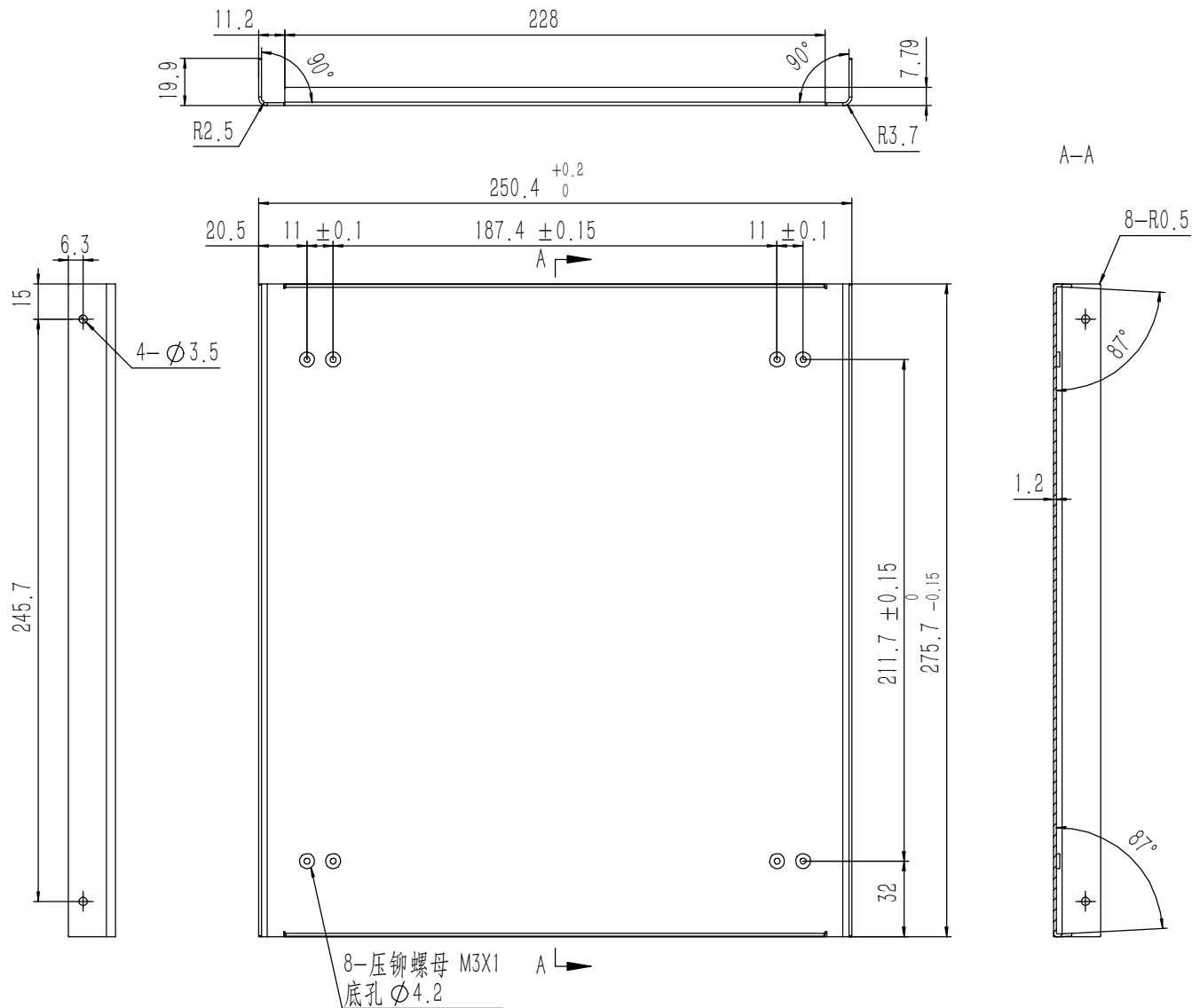
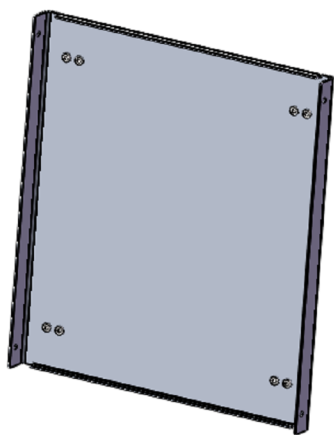
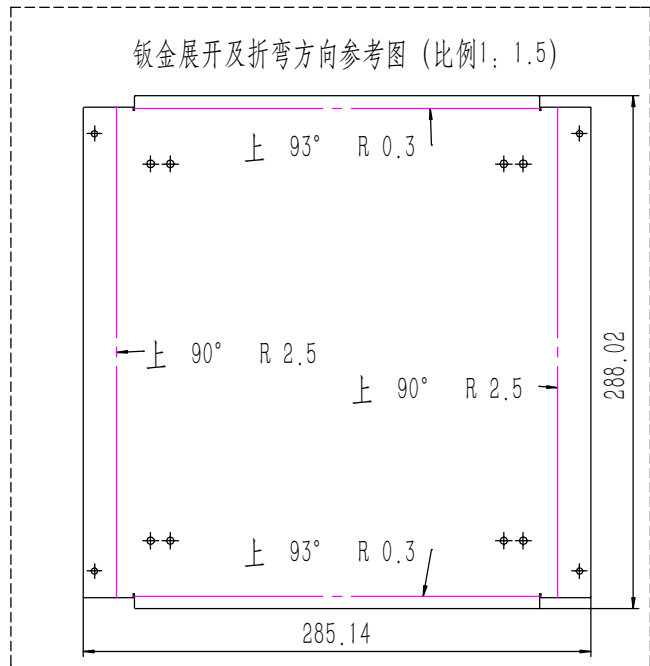

技术要求:

- 1、零件加工表面不应有划痕、擦伤等损伤零件表面的缺陷;
- 2、去除毛刺飞边, 锐角倒钝;
- 3、未标注尺寸见3D数模。

Tolerances (未注公差): 0.5 to 6 ± 0.1 6 to 30 ± 0.2 30 to 120 ± 0.3 120 to 400 ± 0.4	Material (材料):	5052-H32	YONGU 永固				
	Weight: (重量) (Kg):	0.264					
Break sharp edges (未注锐边倒角): Ch 0.05 to 0.25 x45°	Protection: (表面处理):		Drawing Number (图号): YG-D01-0000-003				
	Angular tolerances (未注角度公差): <6° ± 10' <30° ± 20' <120° ± 30' >120° ± 1°	Part Name (零/部件名称):		下盖板			
Position tolerances (未注位置公差): ± 0.05	Drawn by (绘图):	莫永康	Date (日期):	2020.05.22	Size: (图幅):	A1	Sheet (页数): 1 / 1
	Signature by (批准):		Date (日期):		Scale (比例):	1:1	
			Date (日期):		Revision (版本):	A1	

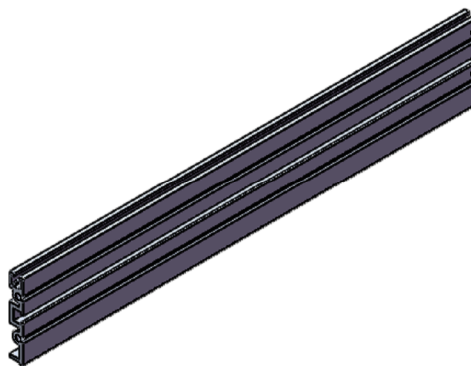
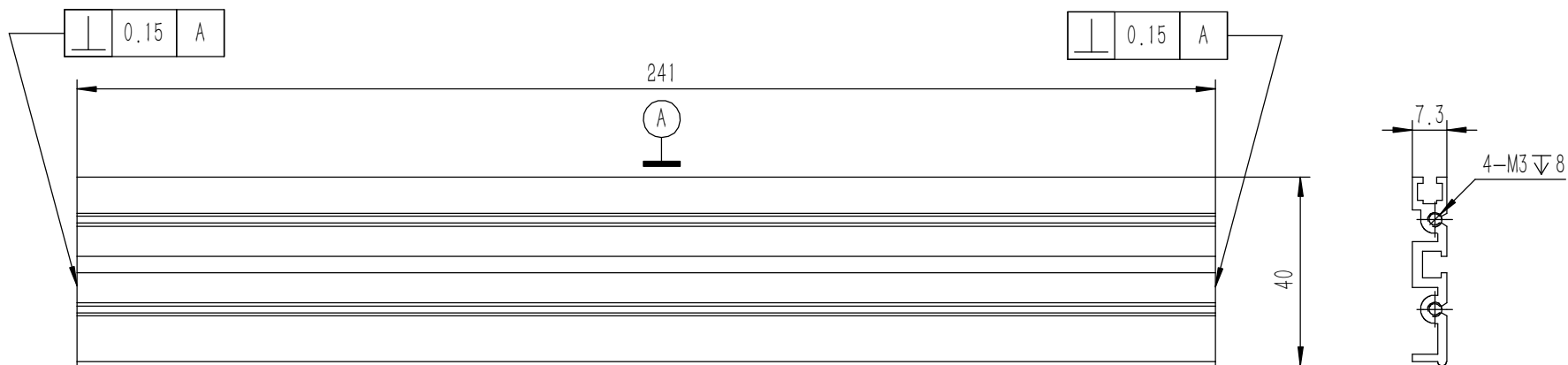

技术要求:

- 1、零件加工表面不应有划痕、擦伤等损伤零件表面的缺陷;
- 2、去除毛刺飞边, 锐角倒钝;
- 3、未标注尺寸见3D数模。

Tolerances (未注公差): 0.5 to 6 ± 0.1 6 to 30 ± 0.2 30 to 120 ± 0.3 120 to 400 ± 0.4	Material (材料):	6063-T5		YONGU 永固				
	Weight: (重量) (Kg)	0.093						
Break sharp edges (未注锐边倒角): Ch 0.05 to 0.25 x45°	Protection: (表面处理):			Drawing Number (图号): YG-D01-0000-011				
	Part Name (零/部件名称):	D中间横梁						
Position tolerances (未注位置公差): ±0.05	Angular tolerances (未注角度公差): <6° ± 10' <30° ± 20' <120° ± 30' >120° ± 1°	Drawn by (绘图):	邓展锋	Date (日期):	2020.05.22	Size (图幅):	A3	Sheet (页数): 1 / 1
		Check by (校对):		Date (日期):		Scale (比例):	1:1	
		Signature by (批准):		Date (日期):		Revision (版本):		

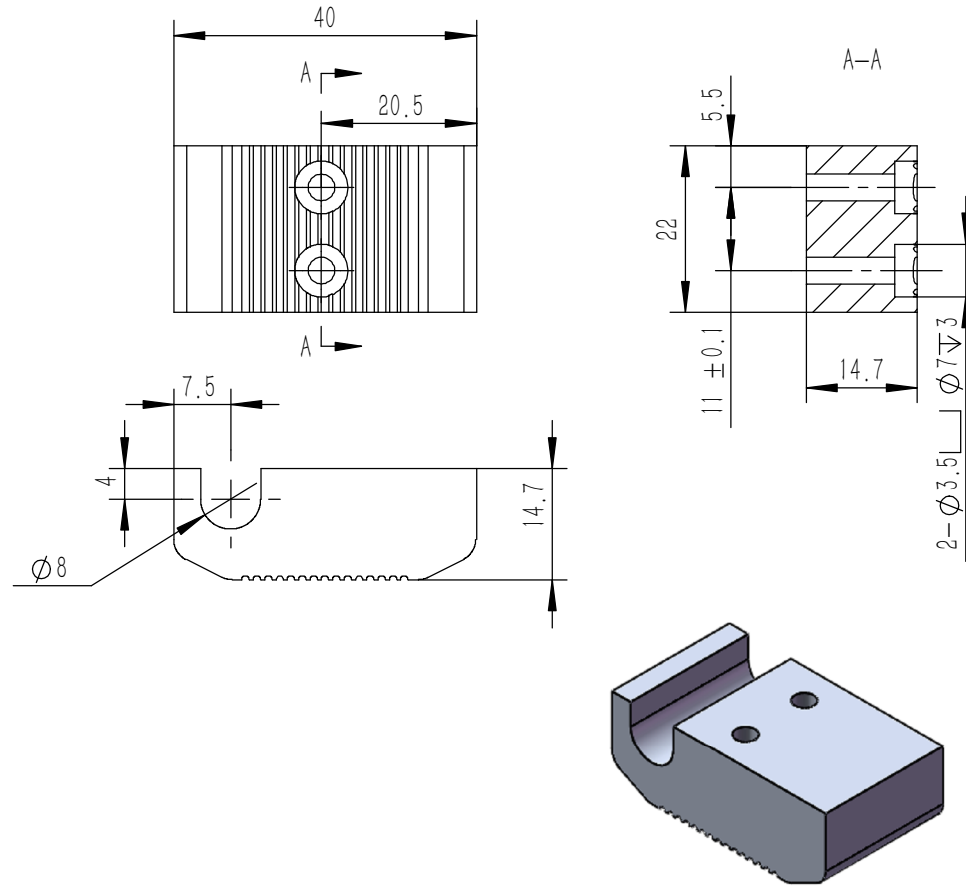

技术要求:

- 1、零件加工表面不应有划痕、擦伤等损伤零件表面的缺陷;
- 2、去除毛刺飞边, 锐角倒钝;
- 3、未标注尺寸见3D数模。

Tolerances (未注公差): 0.5 to 6 ± 0.1 6 to 30 ± 0.2 30 to 120 ± 0.3 120 to 400 ± 0.4	Material (材料): 6063-T5	YONGU 永固	
	Weight: (重量) (Kg) 0.028		
Break sharp edges (未注锐边倒角): Ch 0.05 to 0.25 x45°	Protection: (表面处理):	Part Name (零/部件名称):	
	Position tolerances (未注位置公差): ±0.05	D后机脚	
Angular tolerances (未注角度公差): <6° ± 10' <30° ± 20' <120° ± 30' >120° ± 1°	Part Name (零/部件名称):	Drawing Number (图号):	
	Part Name (零/部件名称):	D后机脚	
	Drawn by (绘图): 邓展锋	Date (日期): 2020.05.22	Size: (图幅): A4
	Check by (校对):	Date (日期):	Scale (比例): 1:1
	Signature by (批准):	Date (日期):	Sheet (页数): 1 / 1
			Revision (版本):

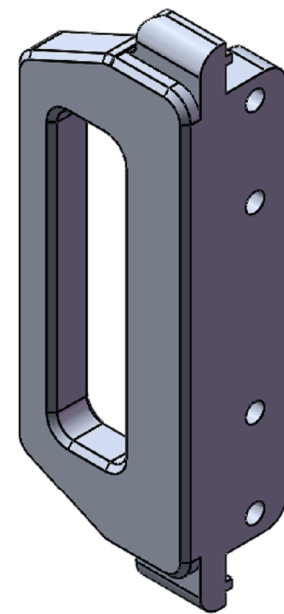
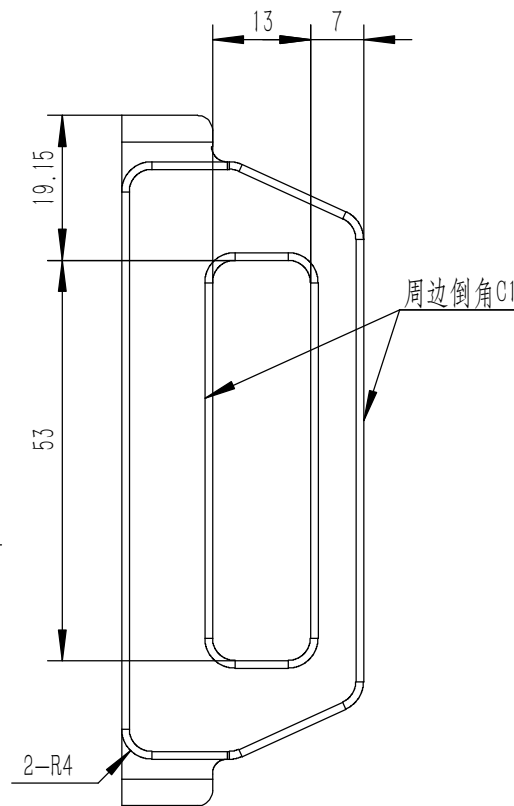
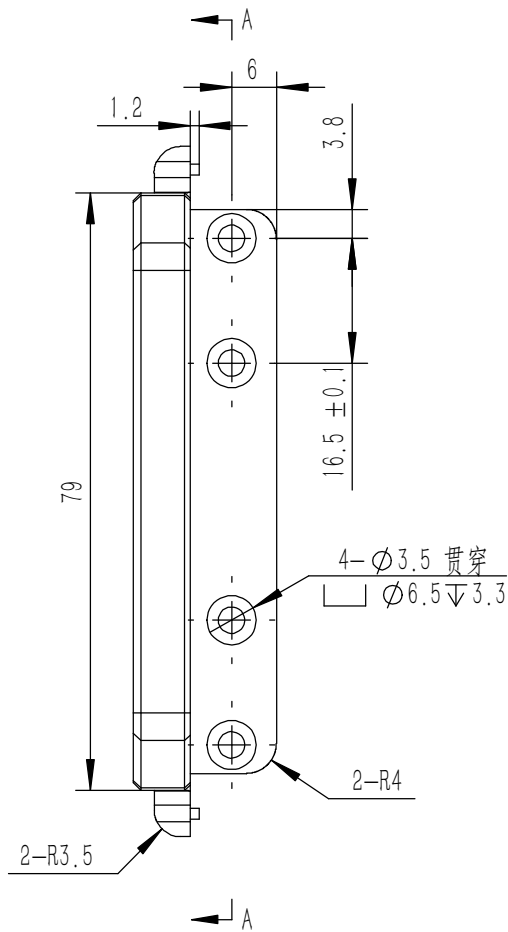
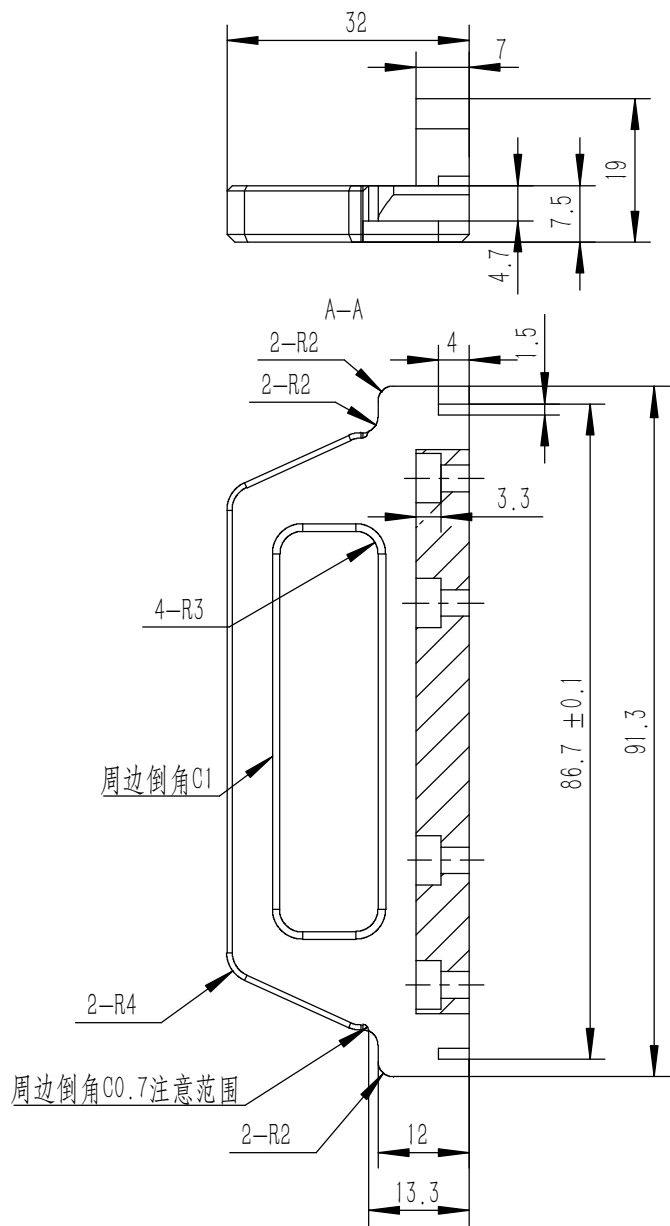

技术要求:

- 1、零件加工表面不应有划痕、擦伤等损伤零件表面的缺陷;
- 2、去除毛刺飞边, 锐角倒钝;
- 3、未标注尺寸见3D数模。

Tolerances (未注公差): 0.5 to 6 ± 0.1 6 to 30 ± 0.2 30 to 120 ± 0.3 120 to 400 ± 0.4	Material (材料): 6063-T5	YONGU 永固	
	Weight: (重量) (Kg) 0.050		
Break sharp edges (未注锐边倒角): Ch 0.05 to 0.25 x45°	Protection: (表面处理):	Part Name (零/部件名称):	
	Position tolerances (未注位置公差): ± 0.05	Drawing Number (图号): YG-D01-0000-009	
Angular tolerances (未注角度公差): <6° ± 10' <30° ± 20' <120° ± 30' >120° ± 1°	D后防护		Scale (比例): 1:1
	Drawn by (绘图): 邓展锋	Date (日期): 2020.05.14	Sheet (页数):
	Check by (校对):	Date (日期):	Sheet (页数):
	Signature by (批准):	Date (日期):	Revision (版本): A1
			1 / 1

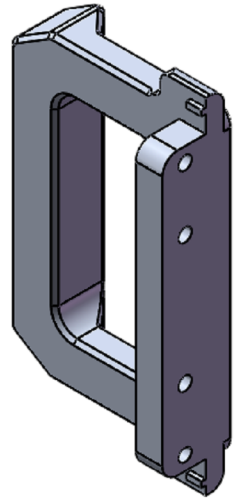
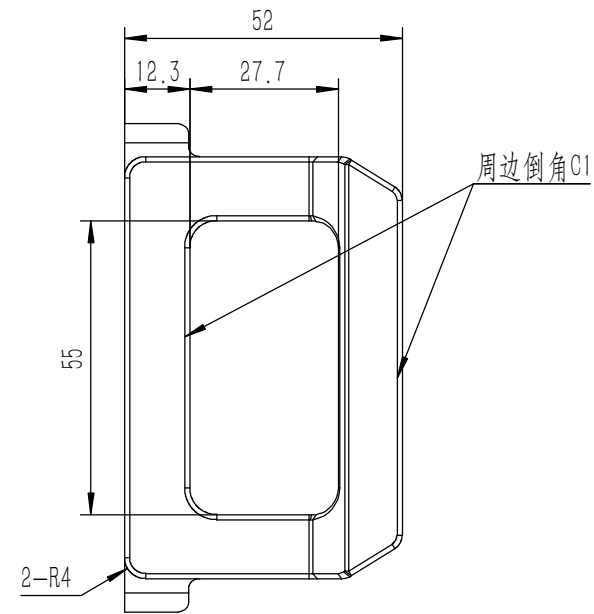
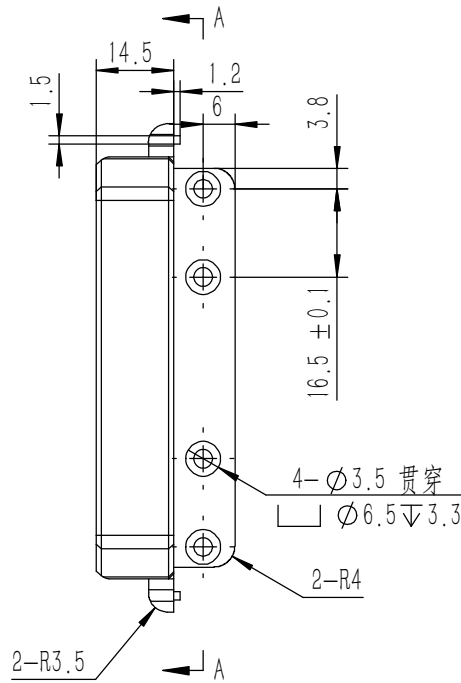
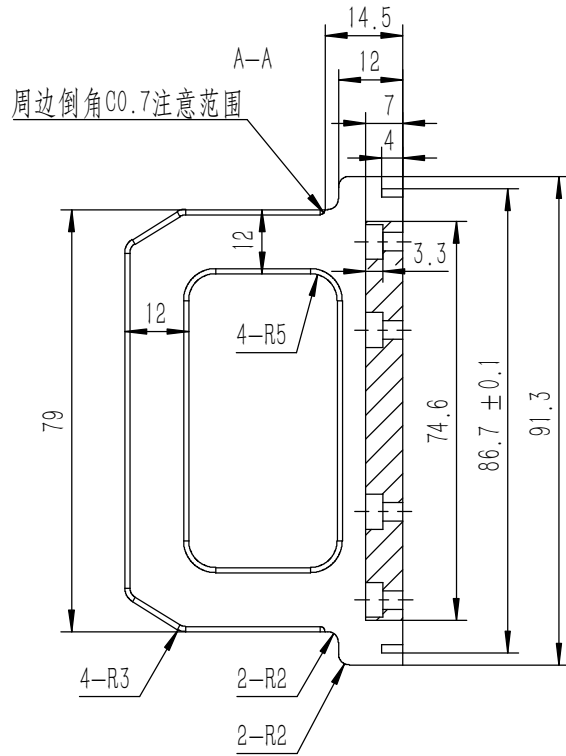
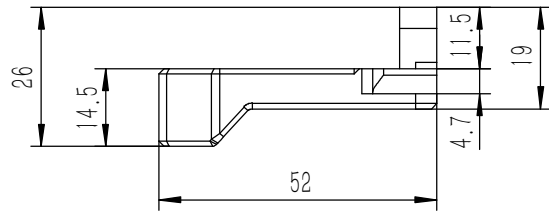

技术要求:

- 1、零件加工表面不应有划痕、擦伤等损伤零件表面的缺陷;
- 2、去除毛刺飞边,锐角倒钝;
- 3、未标注尺寸见3D数模。

Tolerances (未注公差): 0.5 to 6 ± 0.1 6 to 30 ± 0.2 30 to 120 ± 0.3 120 to 400 ± 0.4	Material (材料):	6063-T5		YONGU 永固
	Weight: (重量) (Kg)	0.084		
Break sharp edges (未注锐边倒角): Ch 0.05 to 0.25 x45°	Protection: (表面处理):			Drawing Number (图号): YG-D01-0000-008
	Angular tolerances (未注角度公差): <6° ± 10' <30° ± 20' <120° ± 30' >120° ± 1°	Part Name (零/部件名称):	D拉手	
Position tolerances (未注位置公差): ±0.05	Drawn by (绘图):	邓展锋	Date (日期): 2020.05.22	Size (图幅): A3
		Check by (校对):	Date (日期):	Scale (比例): 1:1
	Signature by (批准):	Date (日期):	Revision (版本):	Sheet (页数): 1 / 1

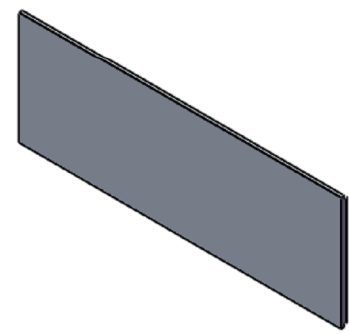
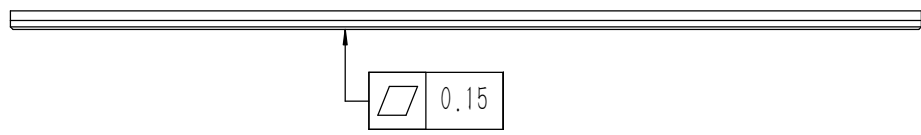
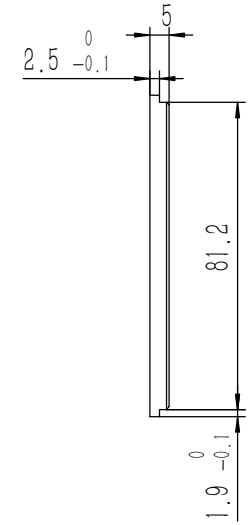
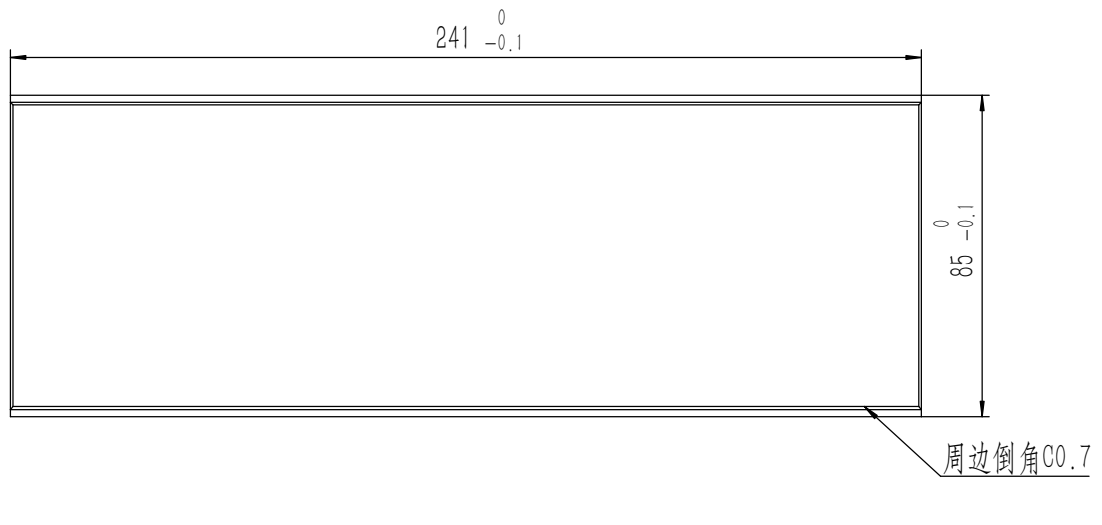

技术要求:
 1、零件加工表面不应有划痕、擦伤等损伤零件表面的缺陷;
 2、去除毛刺飞边, 锐角倒钝;
 3、未标注尺寸见3D数模。

Tolerances (未注公差): 0.5 to 6 ± 0.1 6 to 30 ± 0.2 30 to 120 ± 0.3 120 to 400 ± 0.4	Material (材料):	5052-H32		YONGU 永固
	Weight: (重量) (Kg):	0.268		
Break sharp edges (未注锐边倒角): Ch 0.05 to 0.25 x45°	Protection: (表面处理):			Drawing Number (图号): YG-D01-0000-001
	Position tolerances (未注位置公差): ±0.05	Part Name (零/部件名称): 前后面板		
Angular tolerances (未注角度公差): <6° ± 10' <30° ± 20' <120° ± 30' >120° ± 1°	Drawn by (绘图):	莫永康	Date (日期):	2020.05.22
	Signature by (批准):		Date (日期):	
		Check by (校对):	Date (日期):	
		Scale (比例):	1:1	
		Revision (版本):	A1	
			Sheet (页数):	1 / 1

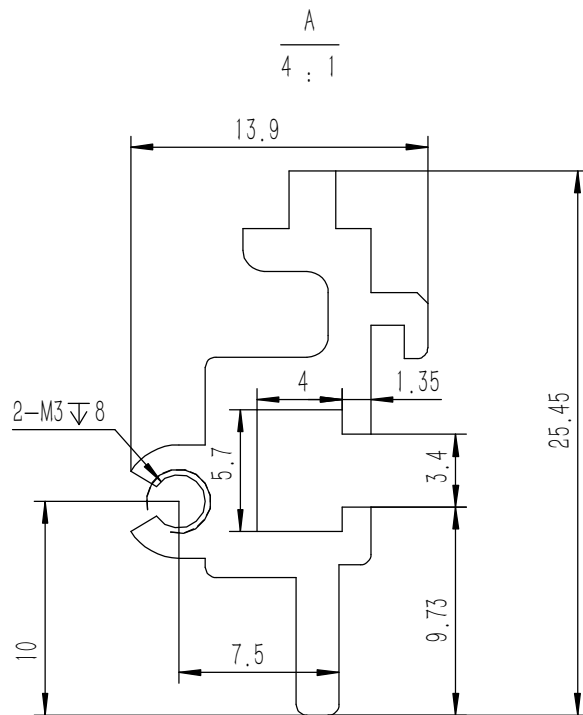
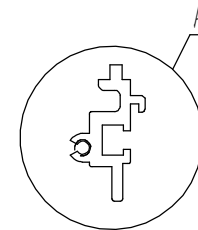
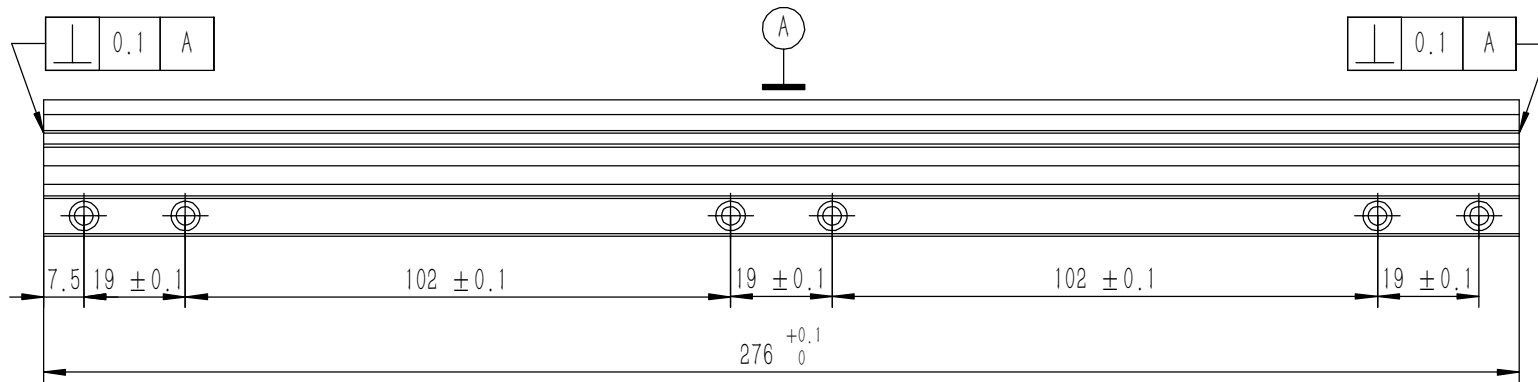

技术要求:

- 1、零件加工表面不应有划痕、擦伤等损伤零件表面的缺陷;
- 2、去除毛刺飞边, 锐角倒钝;
- 3、未标注尺寸见3D数模。

Tolerances (未注公差): 0.5 to 6 ± 0.1 6 to 30 ± 0.2 30 to 120 ± 0.3 120 to 400 ± 0.4	Material (材料):	6063-T5	YONGU 永固				
	Weight: (重量) (Kg)	0.078					
Break sharp edges (未注锐边倒角): Ch 0.05 to 0.25 x45°	Protection: (表面处理):		Drawing Number (图号): YG-D01-0000-007				
	Position tolerances (未注位置公差): ±0.05	Part Name (零/部件名称): 组合侧板					
Angular tolerances (未注角度公差): <6° ± 10' <30° ± 20' <120° ± 30' >120° ± 1°	Drawn by (绘图):	莫永康	Date (日期):	2020.05.22	Size (图幅):	A3	Sheet (页数): 1 / 1
	Check by (校对):		Date (日期):		Scale (比例):	1:1	
	Signature by (批准):		Date (日期):		Revision (版本):	A1	

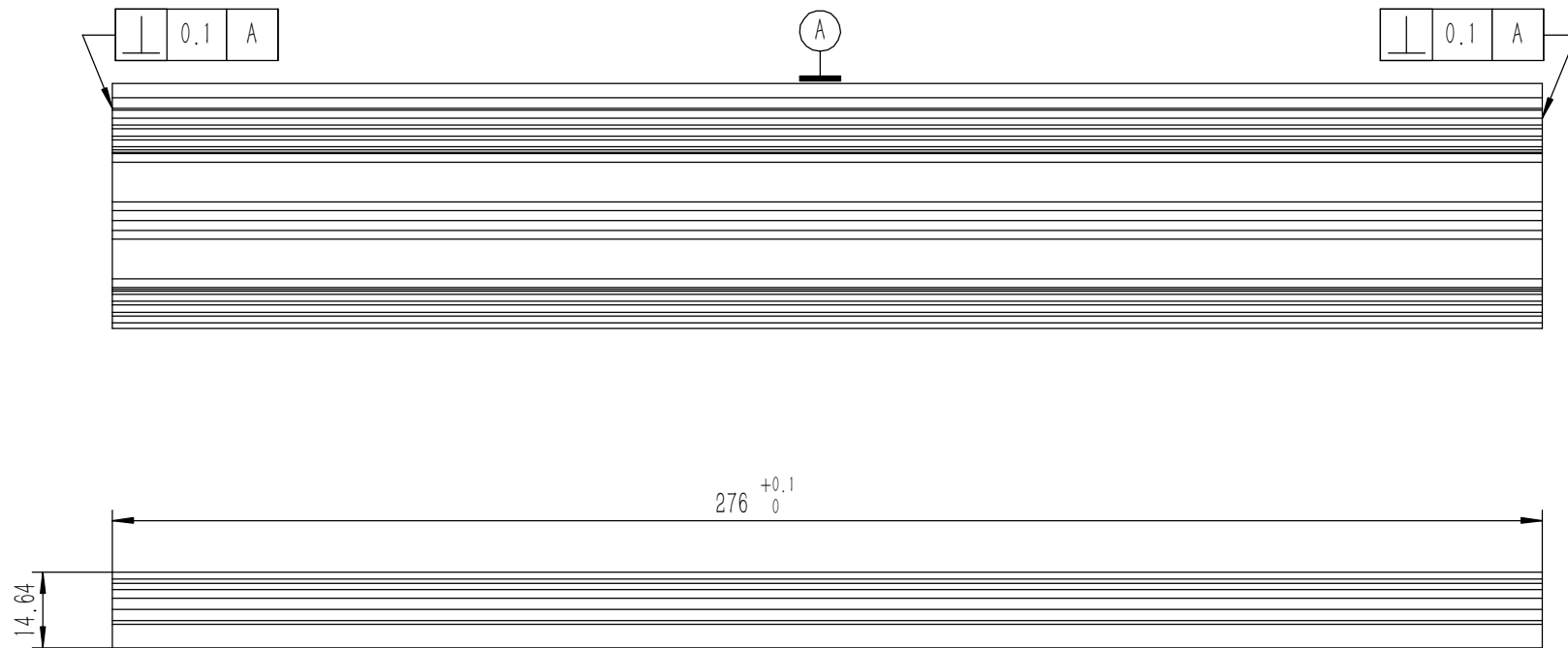
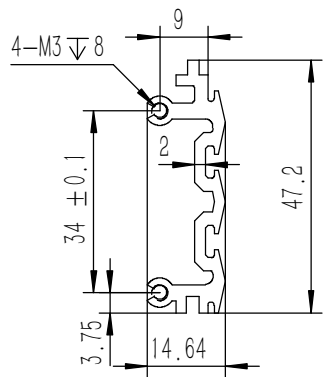

技术要求:

- 1、零件加工表面不应有划痕、擦伤等损伤零件表面的缺陷;
- 2、去除毛刺飞边,锐角倒钝;
- 3、未标注尺寸见3D数模。

Break sharp edges (未注锐边倒角): Ch 0.05 to 0.25 x45°	Angular tolerances (未注角度公差): <6° ± 10' <30° ± 20' <120° ± 30' >120° ± 1°
Position tolerances (未注位置公差): ±0.05	

Tolerances (未注公差): 0.5 to 6 ± 0.1 6 to 30 ± 0.2 30 to 120 ± 0.3 120 to 400 ± 0.4	Material (材料): 6063-T5	
Weight: (重量) (Kg) 0.163	Protection: (表面处理):	
Part Name (零/部件名称): 组合侧板	Drawing Number (图号): YG-D01-0000-006	
Drawn by (绘图): 莫永康	Date (日期): 2020.05.22	Size (图幅): A3
Check by (校对):	Date (日期):	Scale (比例): 1:1
Signature by (批准):	Date (日期):	Revision (版本): A1

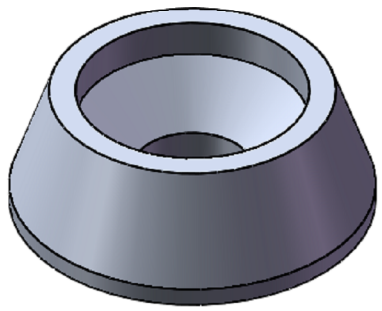
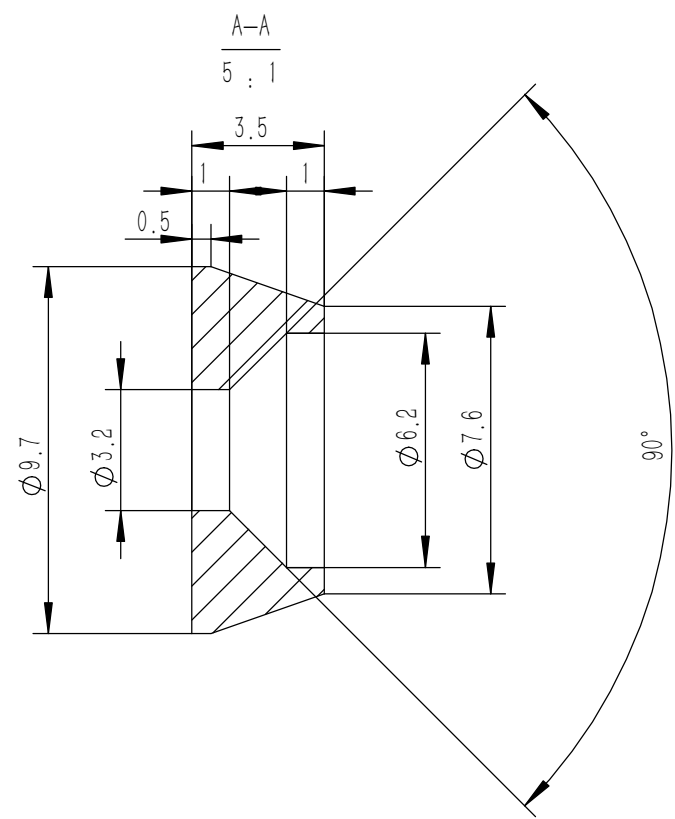
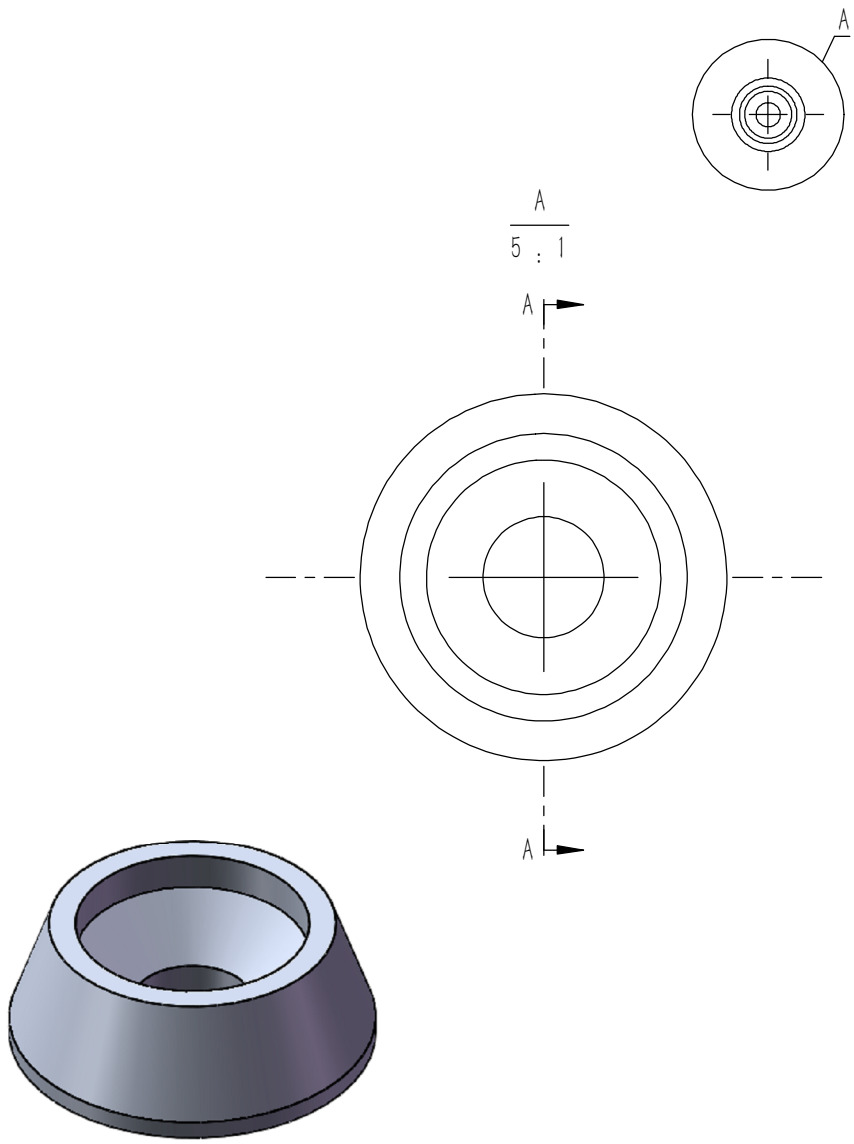

技术要求:

- 1、零件加工表面不应有划痕、擦伤等损伤零件表面的缺陷;
- 2、去除毛刺飞边, 锐角倒钝;
- 3、未标注尺寸见3D数模。

Tolerances (未注公差): 0.5 to 6 ± 0.1 6 to 30 ± 0.2 30 to 120 ± 0.3 120 to 400 ± 0.4	Material (材料):	5052-H32		YONGU 
	Weight: (重量) (Kg)	0.000		
Break sharp edges (未注锐边倒角): Ch 0.05 to 0.25 x45°	Protection: (表面处理):			Drawing Number (图号): YG-TY-ZSJ-001
	Position tolerances (未注位置公差): ± 0.05	Part Name (零/部件名称):	螺丝装饰件 M3	
Angular tolerances (未注角度公差): <6° ± 10' <30° ± 20' <120° ± 30' >120° ± 1°	Drawn by (绘图):	莫永康	Date (日期): 2020.05.22	Size: (图幅): A4
	Check by (校对):		Date (日期):	Scale (比例): 1:1
	Signature by (批准):		Date (日期):	Revision (版本): A1
				Sheet (页数): 1 / 1

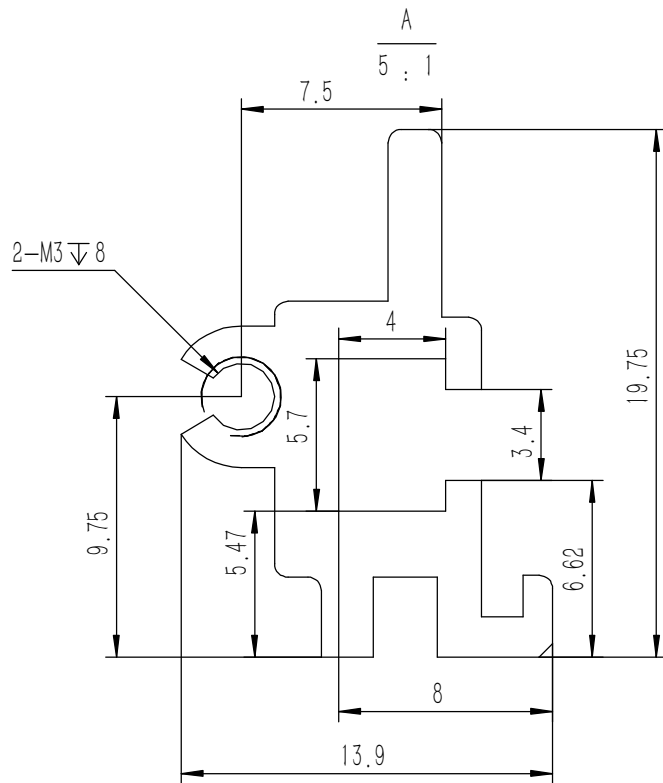
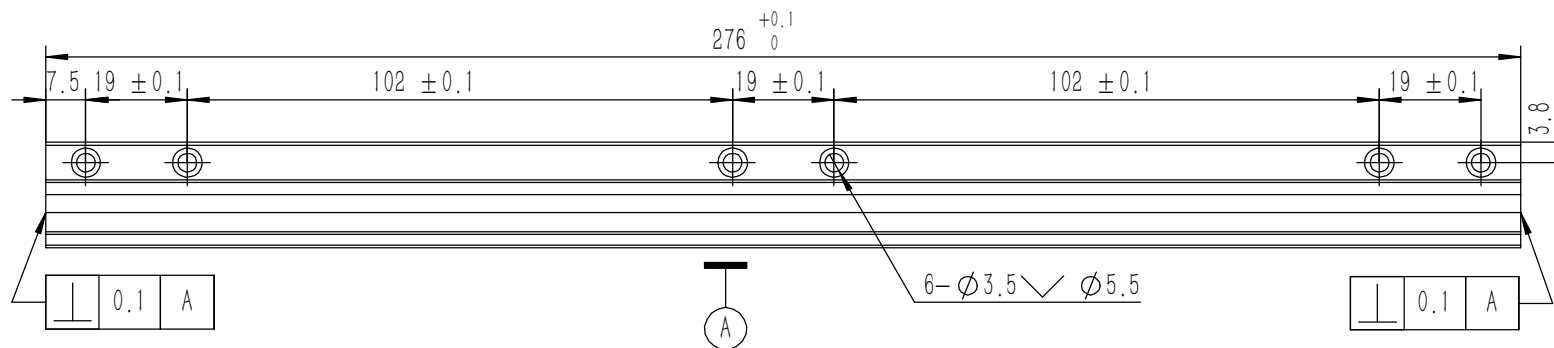

技术要求:

- 1、零件加工表面不应有划痕、擦伤等损伤零件表面的缺陷;
- 2、去除毛刺飞边, 锐角倒钝;
- 3、未标注尺寸见3D数模。

Tolerances (未注公差): 0.5 to 6 ± 0.1 6 to 30 ± 0.2 30 to 120 ± 0.3 120 to 400 ± 0.4	Material (材料):	6063-T5	YONGU 永固
	Weight: (重量) (Kg)	0.067	
Break sharp edges (未注锐边倒角): Ch 0.05 to 0.25 x45°	Protection: (表面处理):		Part Name (零/部件名称): 组合侧板
Angular tolerances (未注角度公差): <6° ± 10' <30° ± 20' <120° ± 30' >120° ± 1°	Part Name (零/部件名称):		
Position tolerances (未注位置公差): ±0.05	Drawn by (绘图):	莫永康	Date (日期): 2020.05.22
	Check by (校对):		Date (日期):
	Signature by (批准):		Date (日期):
	Size (图幅):	A3	Scale (比例): 1:1
	Revision (版本):	A1	Sheet (页数): 1 / 1