

18	YG-C24B-0000-002	后面板	5052-H32	1	1.024	
17	GB-T-819.1-2000-C-NI-M3X6	碳钢镀镍十字沉头螺丝M3X6	普通碳钢	16	0.0004	
16	YG-C24B-0000-012	面板下固定件	电解板	2	0.067	
15	YG-C24B-0000-009	侧板固定 4U-B	6063-T5	4	0.049	
14	YG-C24B-0000-005	组合侧板 4U-100	6063-T5	6	0.248	
13	S-M3-1-ZI	压铆螺母镀白锌M3X1	普通碳钢	8	0.3750	
12	YG-C24B-0000-004	垫板	电解板	1	1.109	
11	GB-T-70.3-2000-C-NI-M3X6	芳生镀白镍内六角沉头螺丝M3X6	普通碳钢	16	0.0004	
10	GB-T-819.1-2000-C-NI-M4X8	碳钢镀镍十字沉头螺丝M4X8	普通碳钢	12	0.001	
9	GB-T-973-1976-C-NI-M3X6	碳钢镀镍十字大扁头螺丝M3X6	普通碳钢	12	0.0006	
8	GB-T-973-1976-C-NI-M3X4	碳钢镀镍十字大扁头螺丝M3X4	普通碳钢	36	0.0005	
7	盲孔压铆螺母柱镀白锌M3X5	压铆螺母柱 M3X5	普通碳钢	8	0.001	
6	YG-C24B-0000-010	侧板连接件 4U	电解板	4	0.044	
5	YG-C24B-0000-011	面板上固定件	电解板	2	0.061	
4	YG-C24B-0000-007	拉手 4U	6063-T5	2	0.170	
3	YG-C24B-0000-003	盖板	5052-H32	2	0.904	
2	YG-C24B-0000-001	前面板	5052-H32	1	1.144	
1	YG-C24B-0000-008	后防护条 4U	6063-T5	2	0.072	
序号	图号	名称	材料	数量	单重	备注

- 技术要求:
- 1、必须按照设计、工艺要求及本规定和有关标准进行装配;
 - 2、所有零部件(包括外购、外协件)必须具有检验合格证方能进行装配;
 - 3、零件在装配前必须清理和清洗干净,不得有毛刺、飞边、氧化皮、锈蚀、切屑、砂粒、灰尘和油污等,并应符合相应清洁度要求;
 - 4、装配过程中零件不得磕碰、划伤和锈蚀;
 - 5、油漆未干的零件不得进行装配;
 - 6、相对运动的零件,装配时接触面间应加润滑油脂;
 - 7、各零、部件装配后相对位置应准确。

Tolerances (未注公差): 0.5 to 6 ± 0.1 6 to 30 ± 0.2 30 to 120 ± 0.3 120 to 400 ± 0.4	Material (材料):	(装配图)	YONGU 永固		
	Weight: (重量) (Kg):	7.740			
Break sharp edges (未注锐边倒角): Ch 0.05 to 0.25 x45°	Protection: (表面处理):		Drawing Number (图号): YG-C24B-0000-000		
	Part Name (零/部件名称):	C24B机箱			
Position tolerances (未注位置公差): ± 0.05	Angular tolerances (未注角度公差): <6° ± 10' <30° ± 20' <120° ± 30' >120° ± 1°	Drawn by (绘图): 莫永康	Date (日期): 2020.05.27	Size (图幅): A0	Sheet (页数): 1 / 1
		Check by (校对):	Date (日期):	Scale (比例): 1:1	
		Signature by (批准):	Date (日期):	Revision (版本): A1	

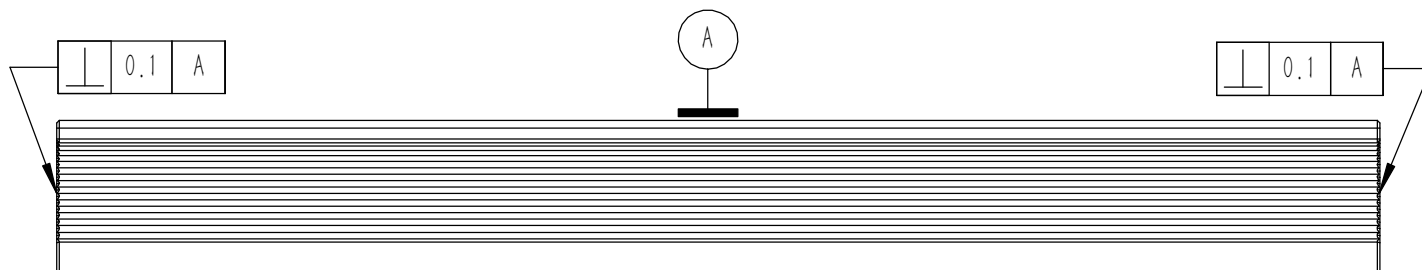
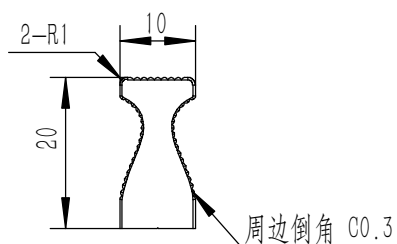
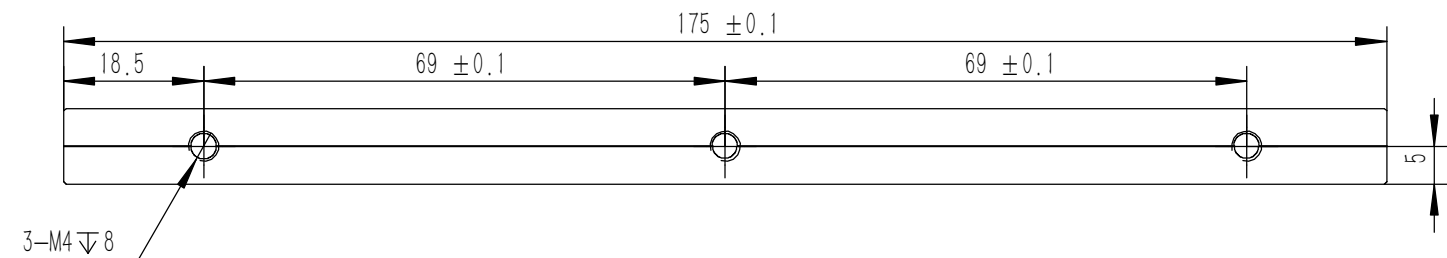

技术要求:

- 1、零件加工表面不应有划痕、擦伤等损伤零件表面的缺陷;
- 2、去除毛刺飞边, 锐角倒钝;
- 3、未标注尺寸见3D数模。

Tolerances (未注公差): 0.5 to 6 ± 0.1 6 to 30 ± 0.2 30 to 120 ± 0.3 120 to 400 ± 0.4	Material (材料): 6063-T5	YONGU 永固	
	Weight: (重量) (Kg) 0.072		
Break sharp edges (未注锐边倒角): Ch 0.05 to 0.25 x45°	Protection: (表面处理):	Part Name (零/部件名称): 后防护条 4U	
	Position tolerances (未注位置公差): ±0.05	Angular tolerances (未注角度公差): <6° ± 10' <30° ± 20' <120° ± 30' >120° ± 1°	Drawing Number (图号): YG-C24B-0000-008
	Drawn by (绘图): 莫永康	Date (日期): 2020.05.27	Size: (图幅): A4
	Check by (校对):	Date (日期):	Scale (比例): 1:1
	Signature by (批准):	Date (日期):	Revision (版本): A1
			Sheet (页数): 1 / 1

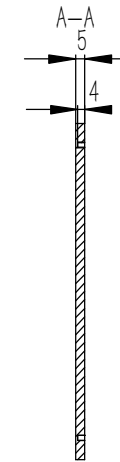
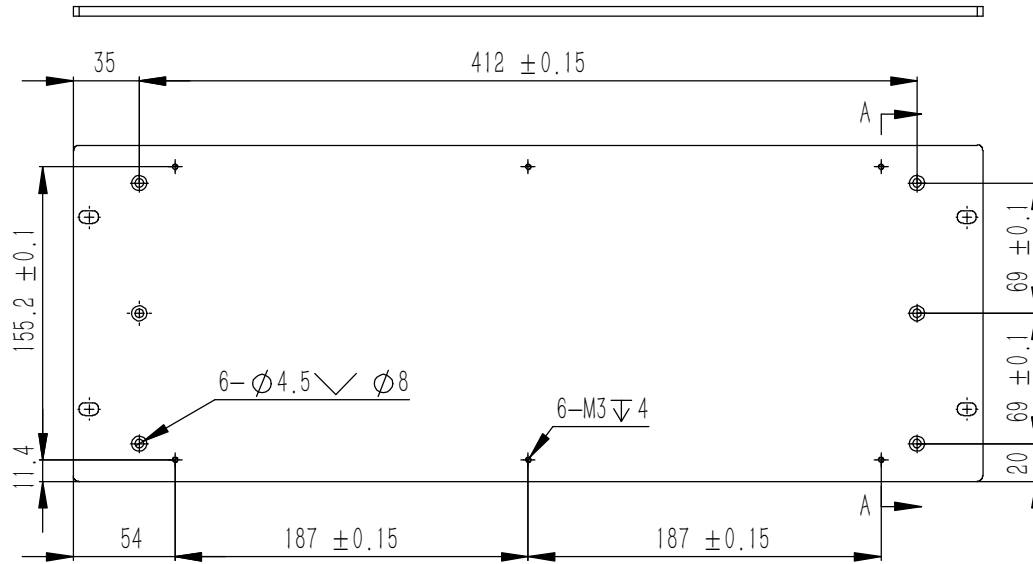
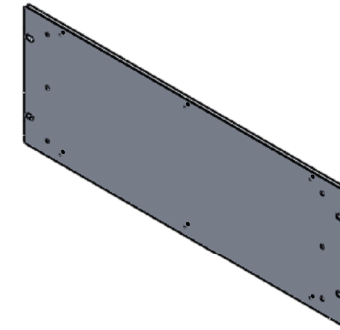
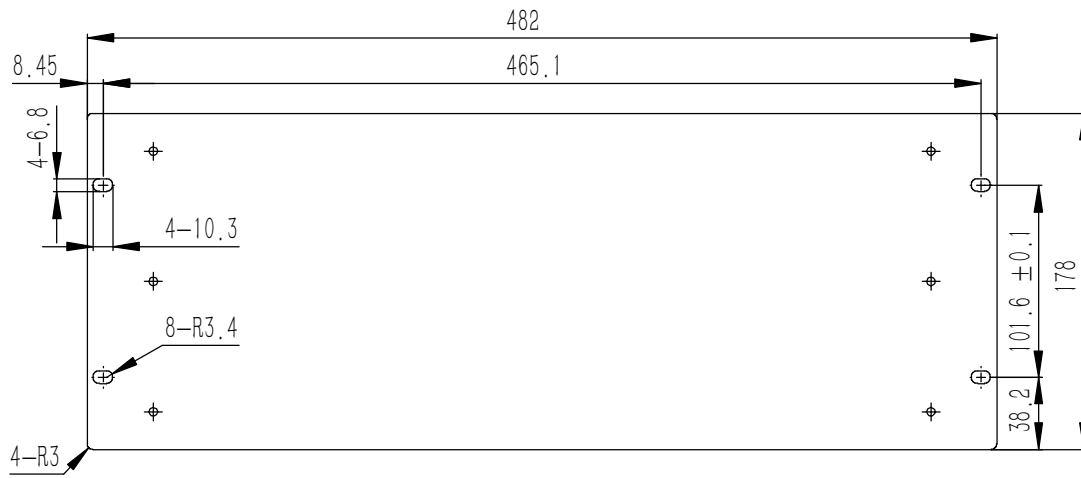

- 技术要求:
- 1、零件加工表面不应有划痕、擦伤等损伤零件表面的缺陷;
 - 2、去除毛刺飞边, 锐角倒钝;
 - 3、未标注尺寸见3D数模。

Break sharp edges (未注锐边倒角): Ch 0.05 to 0.25 x45°	Angular tolerances (未注角度公差): <6° ± 10' <30° ± 20' <120° ± 30' >120° ± 1°
Position tolerances (未注位置公差): ± 0.05	

Tolerances (未注公差): 0.5 to 6 ± 0.1 6 to 30 ± 0.2 30 to 120 ± 0.3 120 to 400 ± 0.4	Material (材料):	5052-H32		YONGU 永固		
	Weight: (重量) (Kg):	1.144				
	Protection: (表面处理):					
	Part Name (零/部件名称):	前面板				
	Material (材料):	5052-H32		Drawing Number (图号):	YG-C24B-0000-001	
	Weight: (重量) (Kg):	1.144		Size (图幅):	A0	
	Protection: (表面处理):			Scale (比例):	1:1	
	Part Name (零/部件名称):	前面板		Revision (版本):	A1	
	Drawn by (绘图):	莫永康	Date (日期):	2020.05.27	Sheet (页数):	1 / 1
	Check by (校对):		Date (日期):			
	Signature by (批准):		Date (日期):			

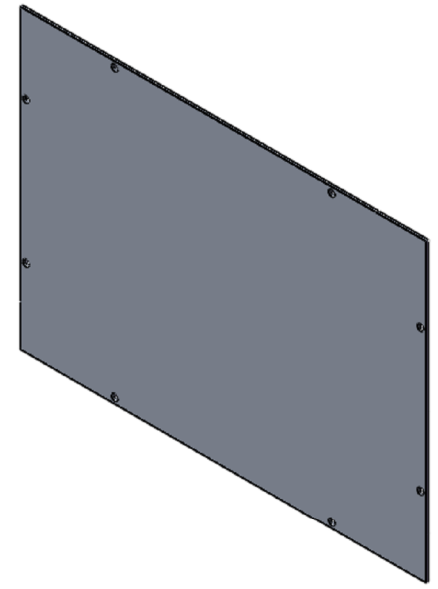
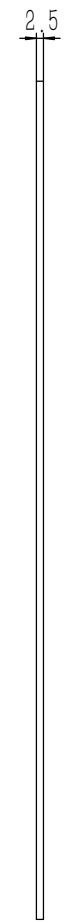
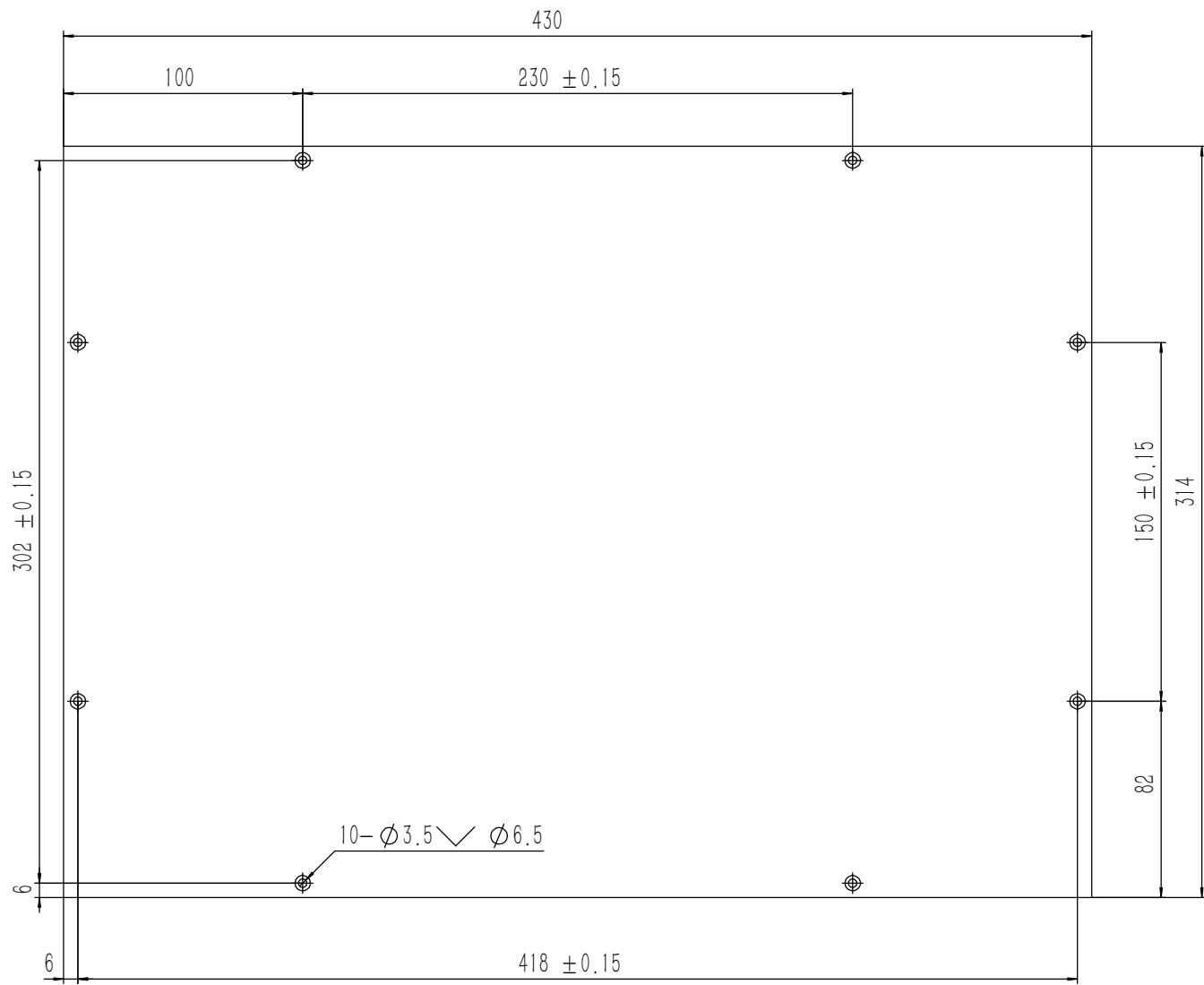

技术要求:

- 1、零件加工表面不应有划痕、擦伤等损伤零件表面的缺陷;
- 2、去除毛刺飞边, 锐角倒钝;
- 3、未标注尺寸见3D数模。

Tolerances (未注公差):	
0.5 to 6	± 0.1
6 to 30	± 0.2
30 to 120	± 0.3
120 to 400	± 0.4

Material (材料):	5052-H32
Weight: (重量) (Kg):	0.904
Protection: (表面处理):	
Part Name (零/部件名称):	盖板



Break sharp edges (未注锐边倒角): Ch 0.05 to 0.25 x45°	Angular tolerances (未注角度公差):
	<6° ± 10'
	<30° ± 20'
	<120° ± 30'
	>120° ± 1°
Position tolerances (未注位置公差):	± 0.05

Drawing Number (图号):		YG-C24B-0000-003	
Drawn by (绘图): 莫永康	Date (日期): 2020.05.27	Size: (图幅): A1	 Sheet (页数): 1 / 1
Check by (校对):	Date (日期):	Scale (比例): 1:1	
Signature by (批准):	Date (日期):	Revision (版本): A1	

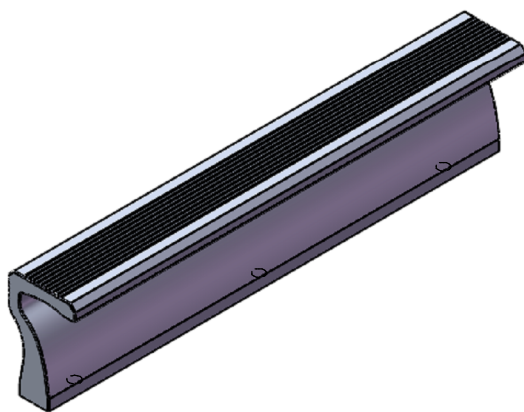
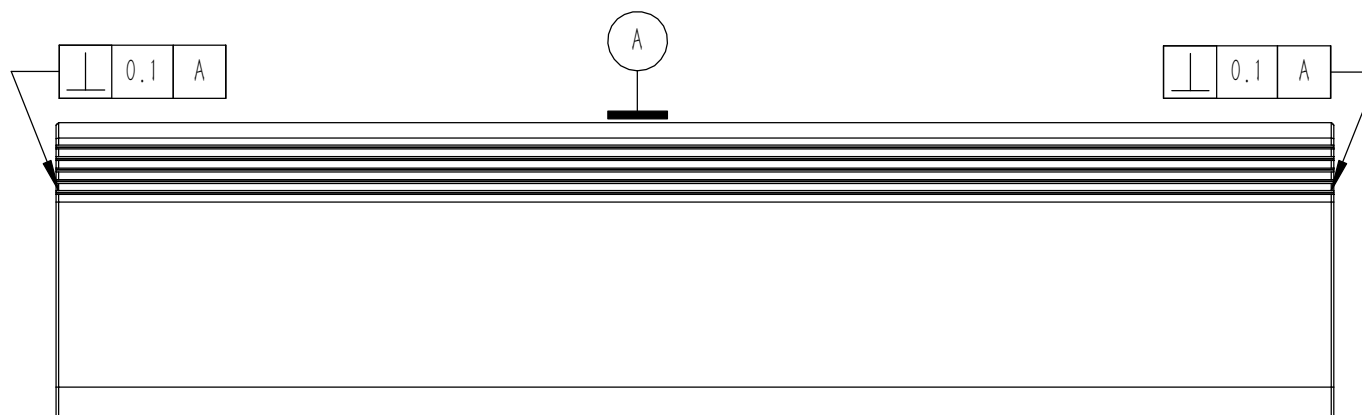
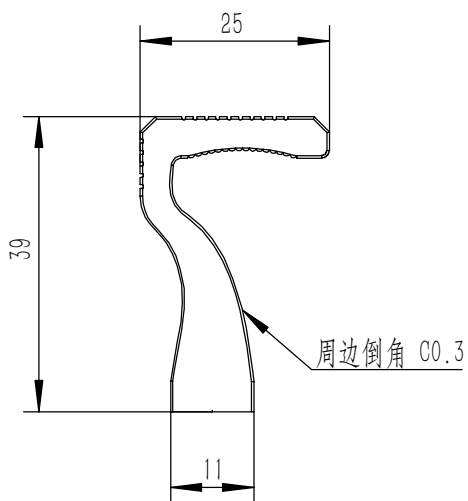
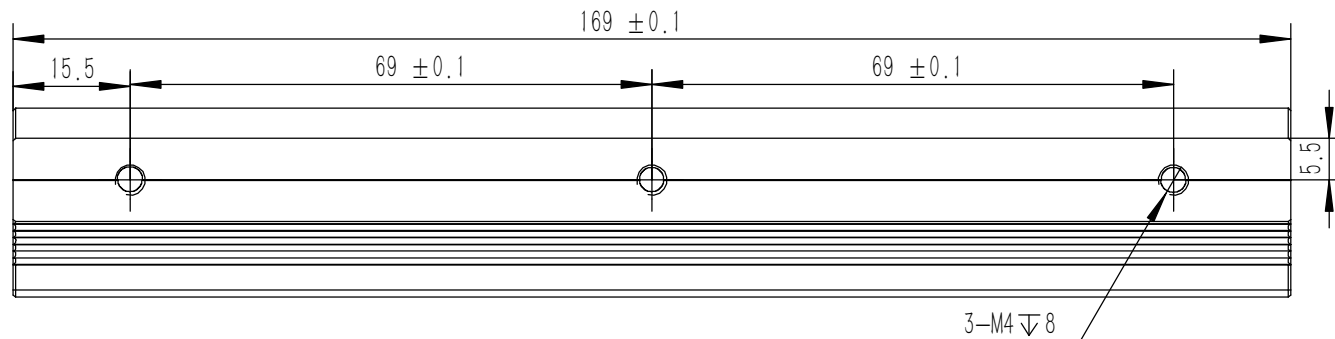

技术要求:

- 1、零件加工表面不应有划痕、擦伤等损伤零件表面的缺陷;
- 2、去除毛刺飞边, 锐角倒钝;
- 3、未标注尺寸见3D数模。

Break sharp edges (未注锐边倒角): Ch 0.05 to 0.25 x45°	Angular tolerances (未注角度公差): <6° ± 10' <30° ± 20' <120° ± 30' >120° ± 1°
Position tolerances (未注位置公差): ±0.05	

Tolerances (未注公差): 0.5 to 6 ± 0.1 6 to 30 ± 0.2 30 to 120 ± 0.3 120 to 400 ± 0.4	Material (材料): 6063-T5	YONGU 永固
Weight: (重量) (Kg) 0.170	Protection: (表面处理):	
Part Name (零/部件名称):	Part Name (零/部件名称): 拉手 4U	Drawing Number (图号): YG-C24B-0000-007
Drawn by (绘图): 莫永康	Date (日期): 2020.05.27	Size: (图幅): A4
Check by (校对):	Date (日期):	Scale (比例): 1:1
Signature by (批准):	Date (日期):	Revision (版本): A1
		Sheet (页数): 1 / 1

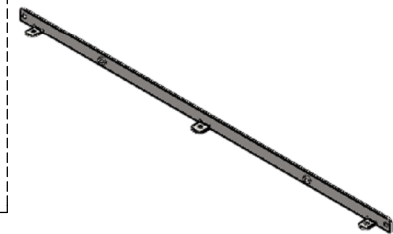
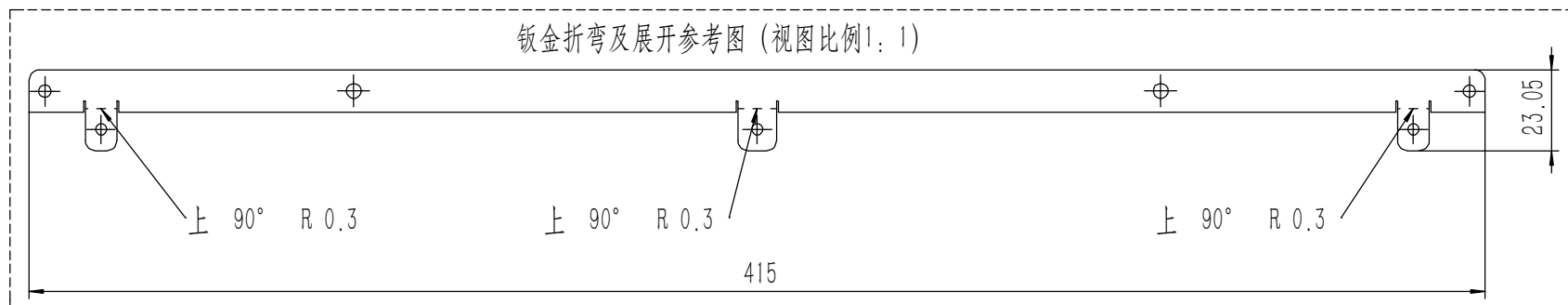
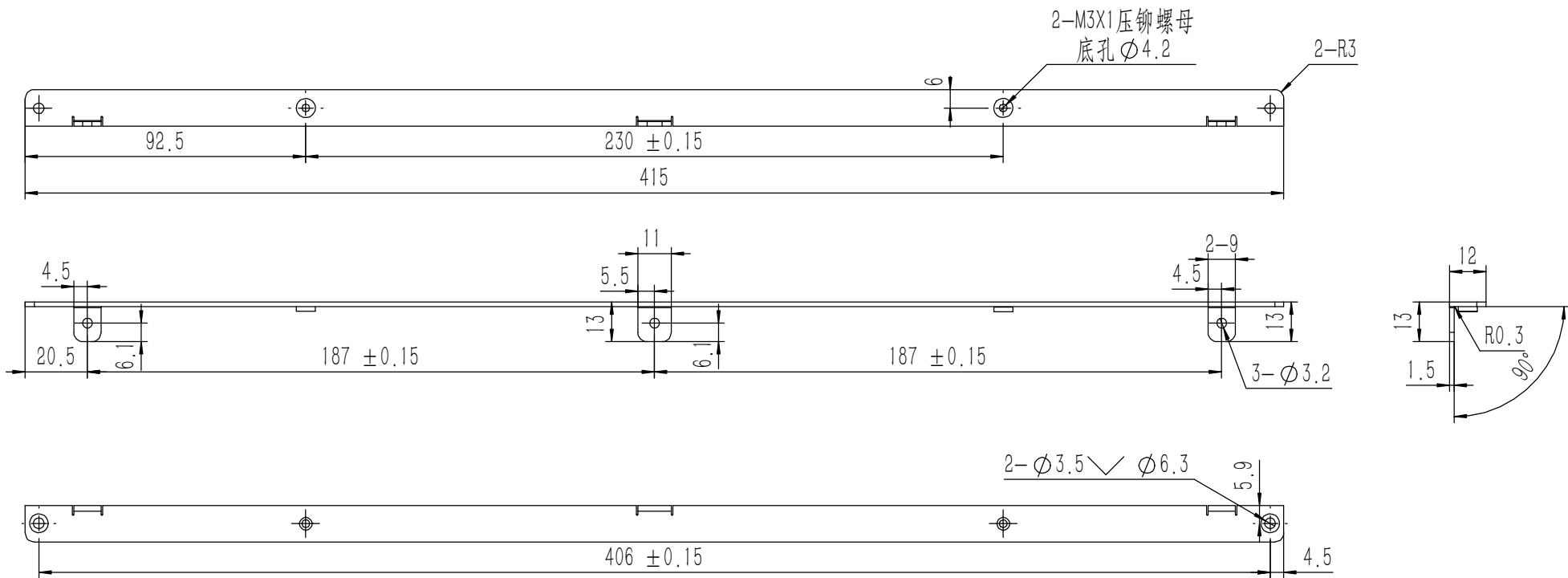

技术要求:

- 1、零件加工表面不应有划痕、擦伤等损伤零件表面的缺陷;
- 2、去除毛刺飞边, 锐角倒钝;
- 3、未标注尺寸见3D数模。

Tolerances (未注公差): 0.5 to 6 ± 0.1 6 to 30 ± 0.2 30 to 120 ± 0.3 120 to 400 ± 0.4	Material (材料):	电解板	YONGU 永固
	Weight: (重量) (Kg):	0.061	
Break sharp edges (未注锐边倒角): Ch 0.05 to 0.25 x45°	Protection: (表面处理):		Drawing Number (图号): YG-C24B-0000-011
	Position tolerances (未注位置公差): ±0.05	Part Name (零/部件名称):	
Angular tolerances (未注角度公差): <6° ± 10' <30° ± 20' <120° ± 30' >120° ± 1°	Drawn by (绘图):	莫永康	Date (日期): 2020.05.27
	Check by (校对):		Date (日期):
	Signature by (批准):		Date (日期):
			Size: (图幅): A2
			Scale (比例): 1:1
			Revision (版本): A1
			Sheet (页数): 1 / 1

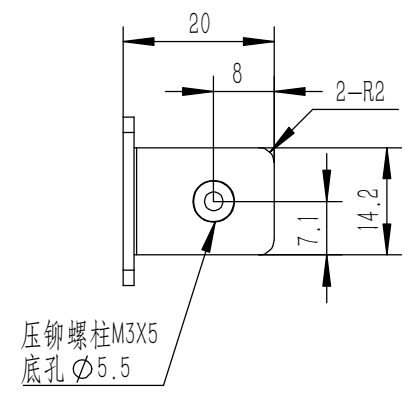
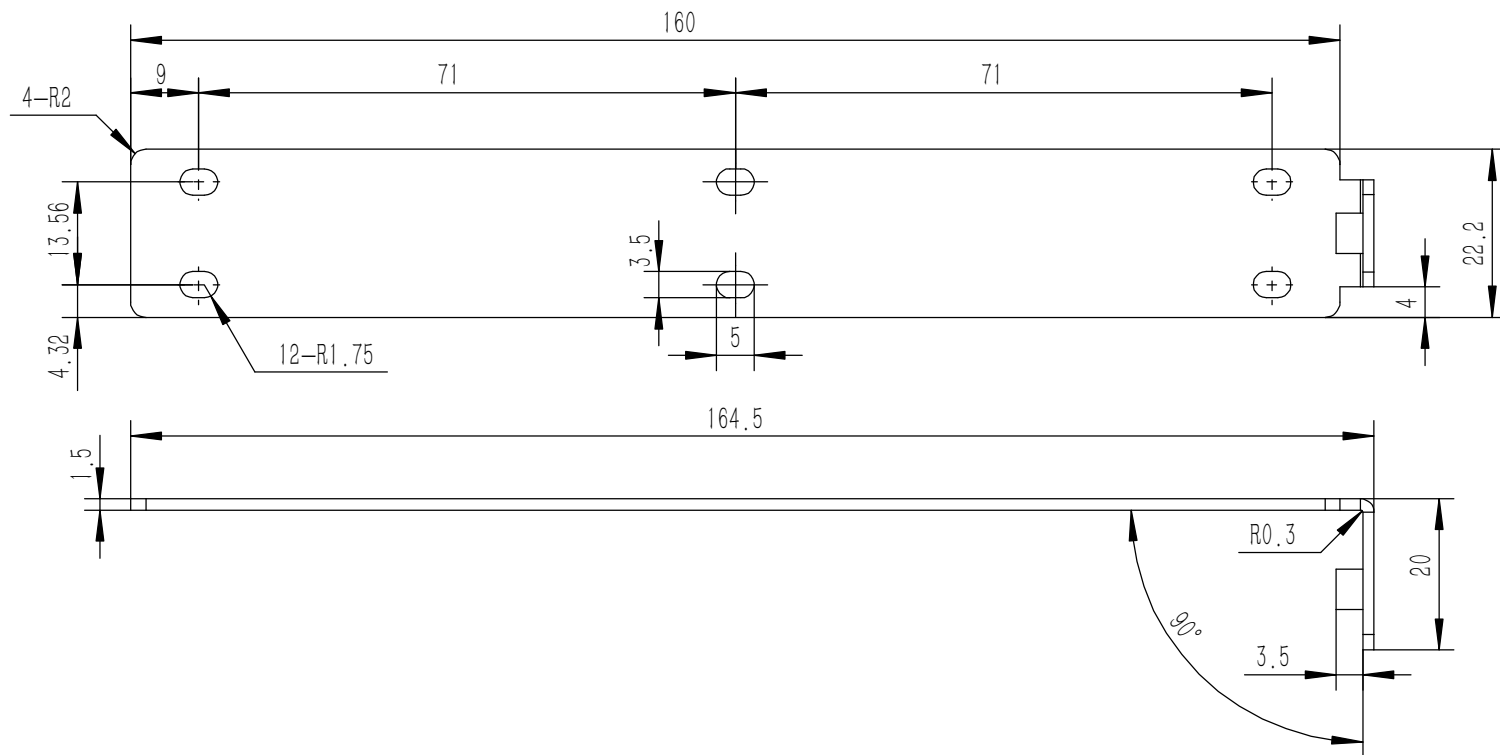

钣金展开及折弯方向参考图 (视图比例1:1)

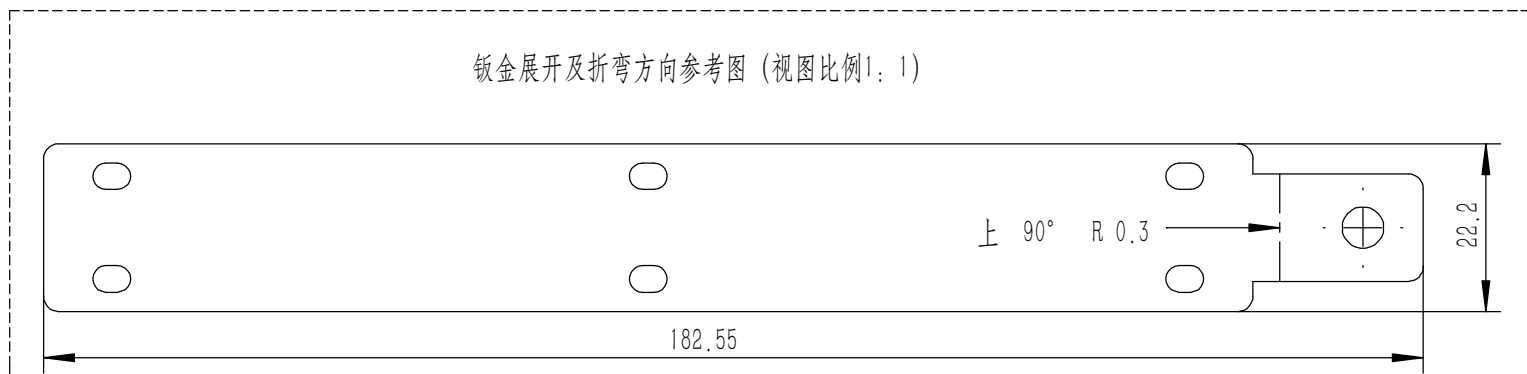

技术要求:
 1、零件加工表面不应有划痕、擦伤等损伤零件表面的缺陷;
 2、去除毛刺飞边,锐角倒钝;
 3、未标注尺寸见3D数模。

Tolerances (未注公差):	
0.5 to 6	± 0.1
6 to 30	± 0.2
30 to 120	± 0.3
120 to 400	± 0.4

Angular tolerances (未注角度公差):	
<6°	± 10'
<30°	± 20'
<120°	± 30'
>120°	± 1°

Break sharp edges (未注锐边倒角):	
Ch 0.05 to 0.25 x45°	
Position tolerances (未注位置公差):	
± 0.05	

Material (材料):	电解板
Weight: (重量) (Kg):	0.045
Protection: (表面处理):	
Part Name (零/部件名称):	侧板连接件 4U
Drawn by (绘图):	莫永康
Check by (校对):	
Signature by (批准):	
Date (日期):	2020.05.26

YONGU 永固		Drawing Number (图号):	
		YG-C24B-0000-010	
Size: (图幅):	A4	Sheet (页数):	1 / 1
Scale (比例):	1:1		
Revision (版本):	A1		

钣金展开及折弯方向参考图 (比例1:1.5)

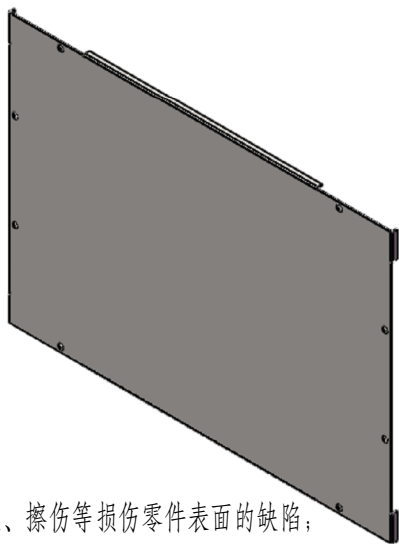
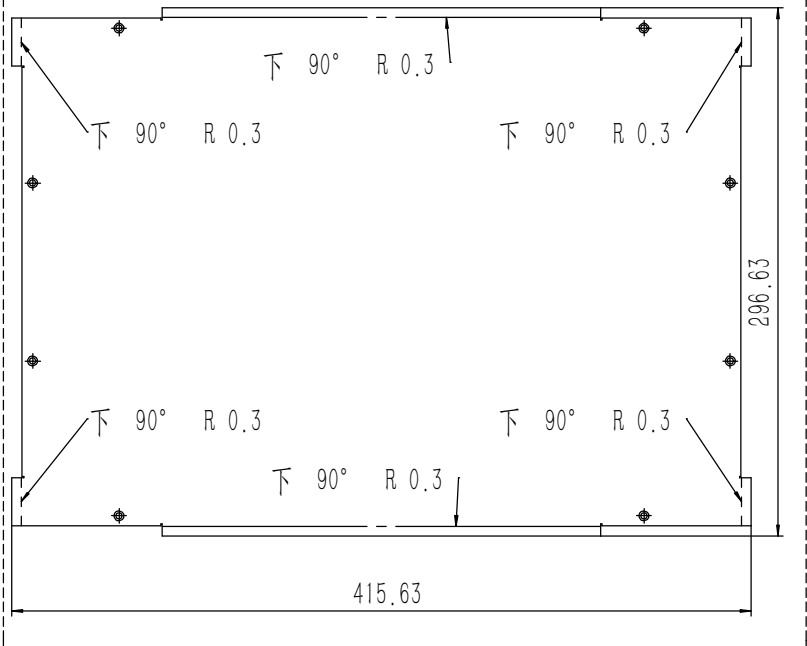

技术要求:

- 1、零件加工表面不应有划痕、擦伤等损伤零件表面的缺陷;
- 2、去除毛刺飞边, 锐角倒钝;
- 3、未标注尺寸见3D数模。

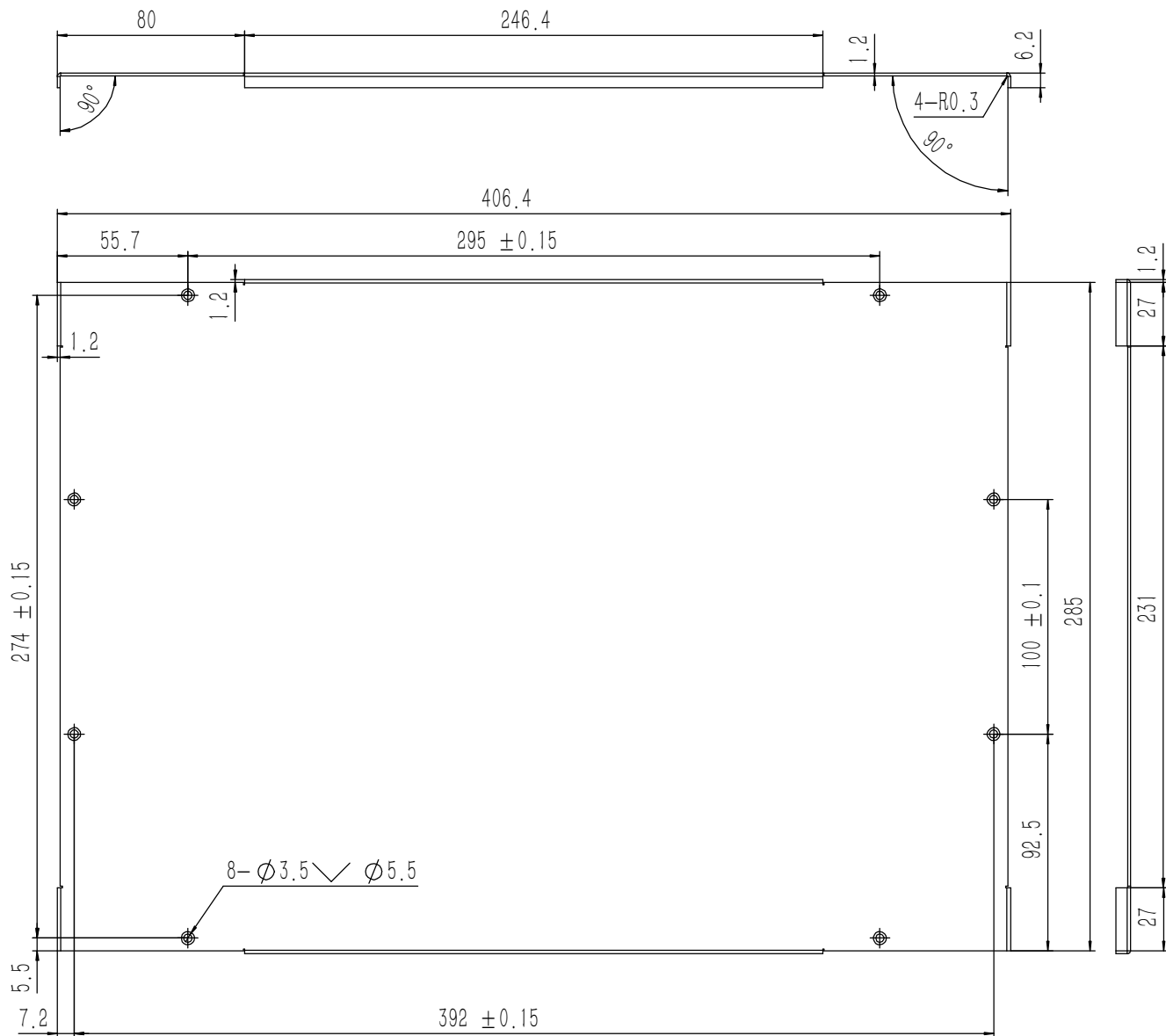

Tolerances (未注公差):	
0.5 to 6	± 0.1
6 to 30	± 0.2
30 to 120	± 0.3
120 to 400	± 0.4

Break sharp edges (未注锐边倒角): Ch 0.05 to 0.25 x45°	Angular tolerances (未注角度公差):
	<6° ± 10'
	<30° ± 20'
	<120° ± 30'
	>120° ± 1°

Material (材料):	电解板
Weight: (重量) (Kg):	1.109
Protection: (表面处理):	
Part Name (零/部件名称):	垫板

		Drawing Number (图号):	
		YG-C24B-0000-004	

Drawn by (绘图): 莫永康	Date (日期): 2020.05.27	Size: (图幅): A1	
Check by (校对):	Date (日期):	Scale (比例): 1:1	
Signature by (批准):	Date (日期):	Revision (版本): A1	Sheet (页数): 1 / 1

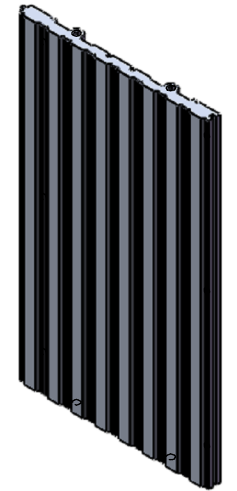
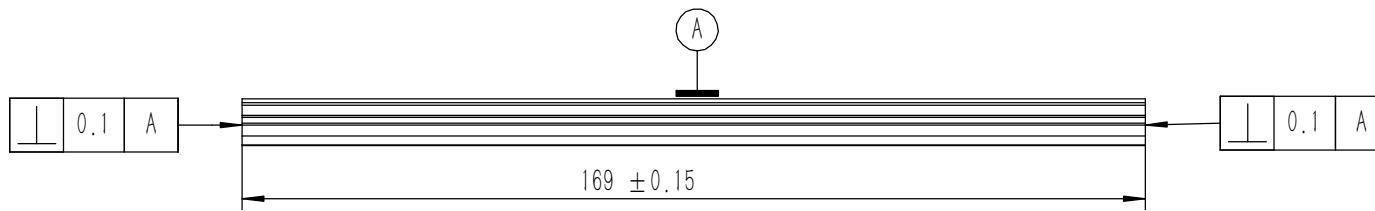
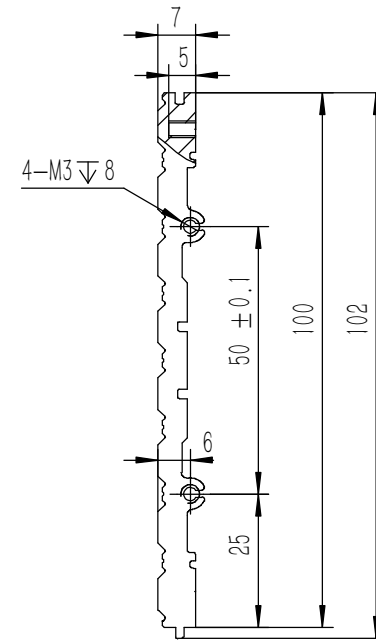
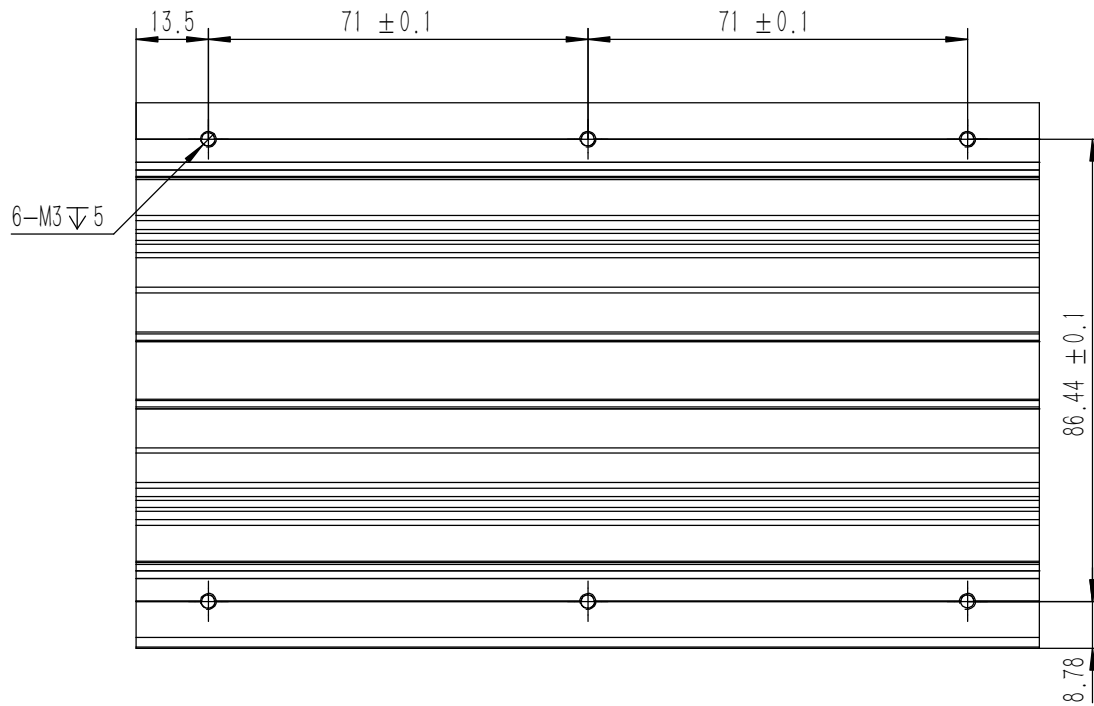

技术要求:

- 1、零件加工表面不应有划痕、擦伤等损伤零件表面的缺陷;
- 2、去除毛刺飞边,锐角倒钝;
- 3、未标注尺寸见3D数模。

Tolerances (未注公差): 0.5 to 6 ± 0.1 6 to 30 ± 0.2 30 to 120 ± 0.3 120 to 400 ± 0.4	Material (材料):	6063-T5		YONGU 永固		
	Weight: (重量) (Kg)	0.248				
Break sharp edges (未注锐边倒角): Ch 0.05 to 0.25 x45°	Protection: (表面处理):					
	Part Name (零/部件名称):	组合侧板 4U-100		Drawing Number (图号): YG-C24B-0000-005		
Position tolerances (未注位置公差): ±0.05	Angular tolerances (未注角度公差): <6° ± 10' <30° ± 20' <120° ± 30' >120° ± 1°	Drawn by (绘图):	莫永康	Date (日期): 2020.05.27	Size (图幅): A3	 Sheet (页数): 1 / 1
		Check by (校对):		Date (日期):	Scale (比例): 1:1	
		Signature by (批准):		Date (日期):	Revision (版本): A1	

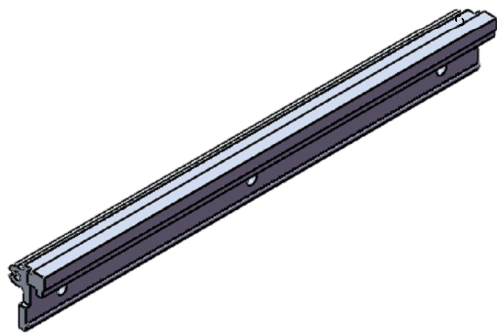
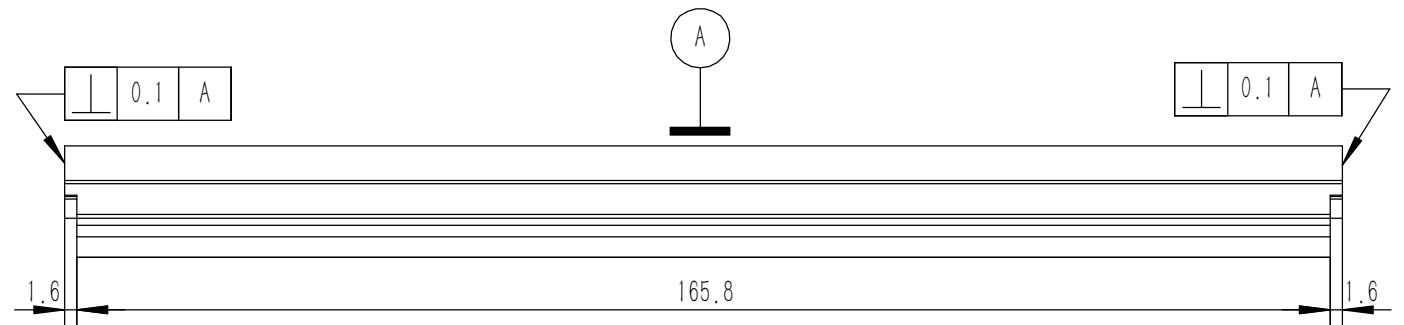
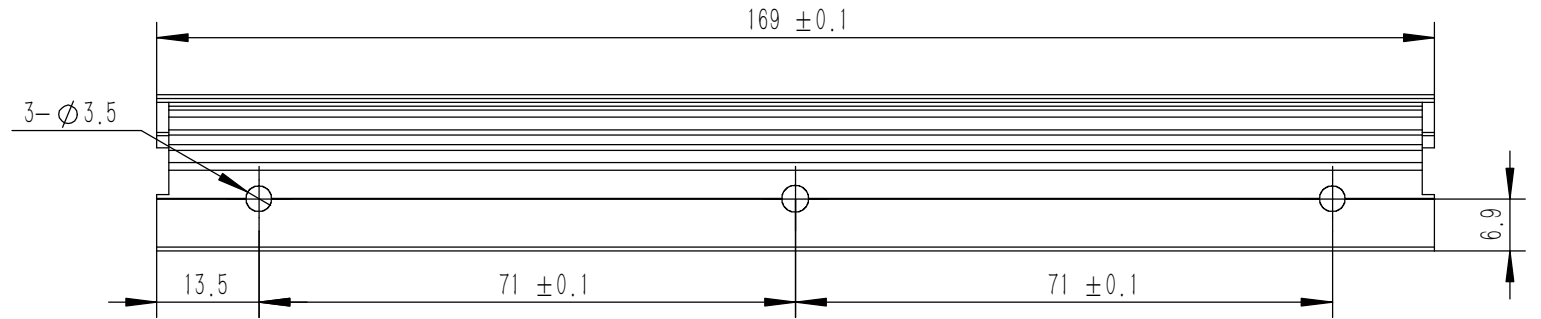
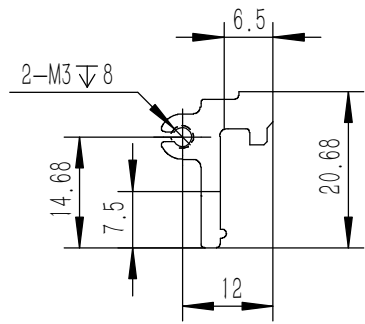

技术要求:

- 1、零件加工表面不应有划痕、擦伤等损伤零件表面的缺陷;
- 2、去除毛刺飞边, 锐角倒钝;
- 3、未标注尺寸见3D数模。

Tolerances (未注公差): 0.5 to 6 ± 0.1 6 to 30 ± 0.2 30 to 120 ± 0.3 120 to 400 ± 0.4	Material (材料): 6063-T5	YONGU 永固	
	Weight: (重量) (Kg) 0.049		
Break sharp edges (未注锐边倒角): Ch 0.05 to 0.25 x45°	Protection: (表面处理):	Part Name (零/部件名称): 侧板固定 4U-B	
	Position tolerances (未注位置公差): ±0.05	Angular tolerances (未注角度公差): <6° ± 10' <30° ± 20' <120° ± 30' >120° ± 1°	Drawing Number (图号): YG-C24B-0000-009
	Material (材料): 6063-T5	Drawn by (绘图): 莫永康	Date (日期): 2020.05.26
	Weight: (重量) (Kg) 0.049	Check by (校对):	Date (日期):
	Protection: (表面处理):	Signature by (批准):	Date (日期):
	Part Name (零/部件名称): 侧板固定 4U-B	Scale (比例): 1:1	Sheet (页数): 1 / 1
	Material (材料): 6063-T5	Revision (版本): A1	

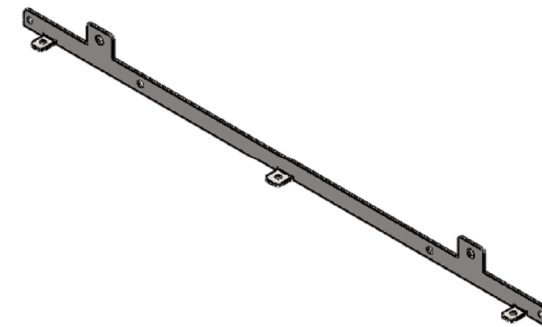
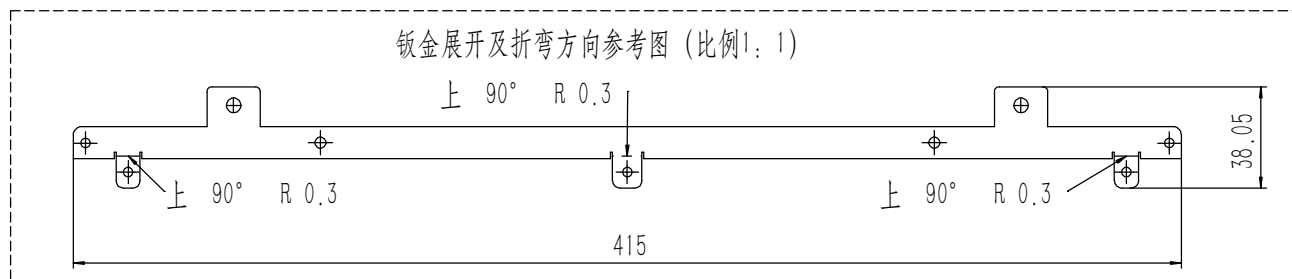
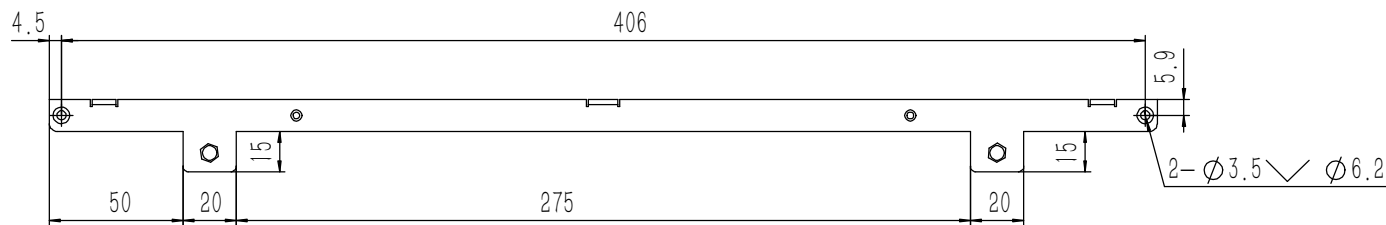
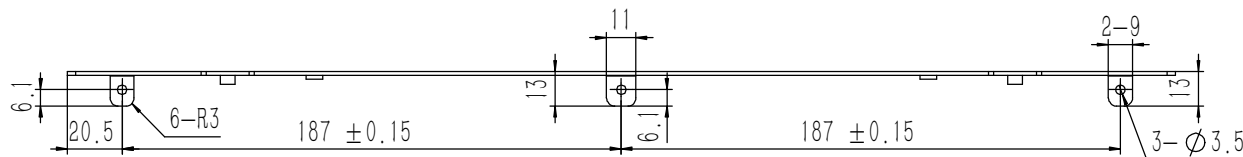
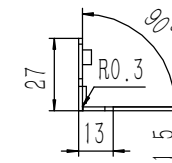
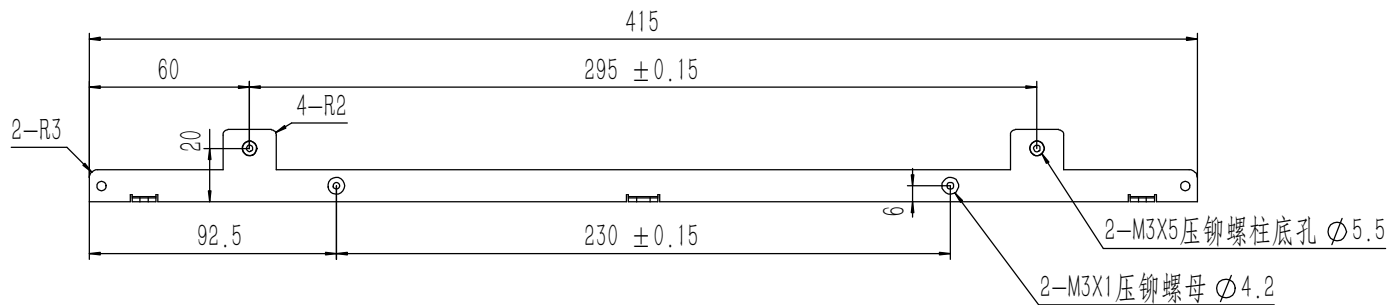

技术要求:

- 1、零件加工表面不应有划痕、擦伤等损伤零件表面的缺陷;
- 2、去除毛刺飞边, 锐角倒钝;
- 3、未标注尺寸见3D数模。

Tolerances (未注公差): 0.5 to 6 ± 0.1 6 to 30 ± 0.2 30 to 120 ± 0.3 120 to 400 ± 0.4	Material (材料): 电解板 Weight: (重量) (Kg): 0.069 Protection: (表面处理): Part Name (零/部件名称): 面板下固定件	Drawing Number (图号): YG-C24B-0000-012	
		Break sharp edges (未注锐边倒角): Ch 0.05 to 0.25 x45°	Angular tolerances (未注角度公差): <6° ± 10' <30° ± 20' <120° ± 30' >120° ± 1'
Position tolerances (未注位置公差): ± 0.05	Signature by (批准):	Date (日期):	Revision (版本): A1
		Date (日期):	Sheet (页数): 1 / 1

YONGU 永固

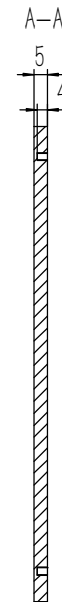
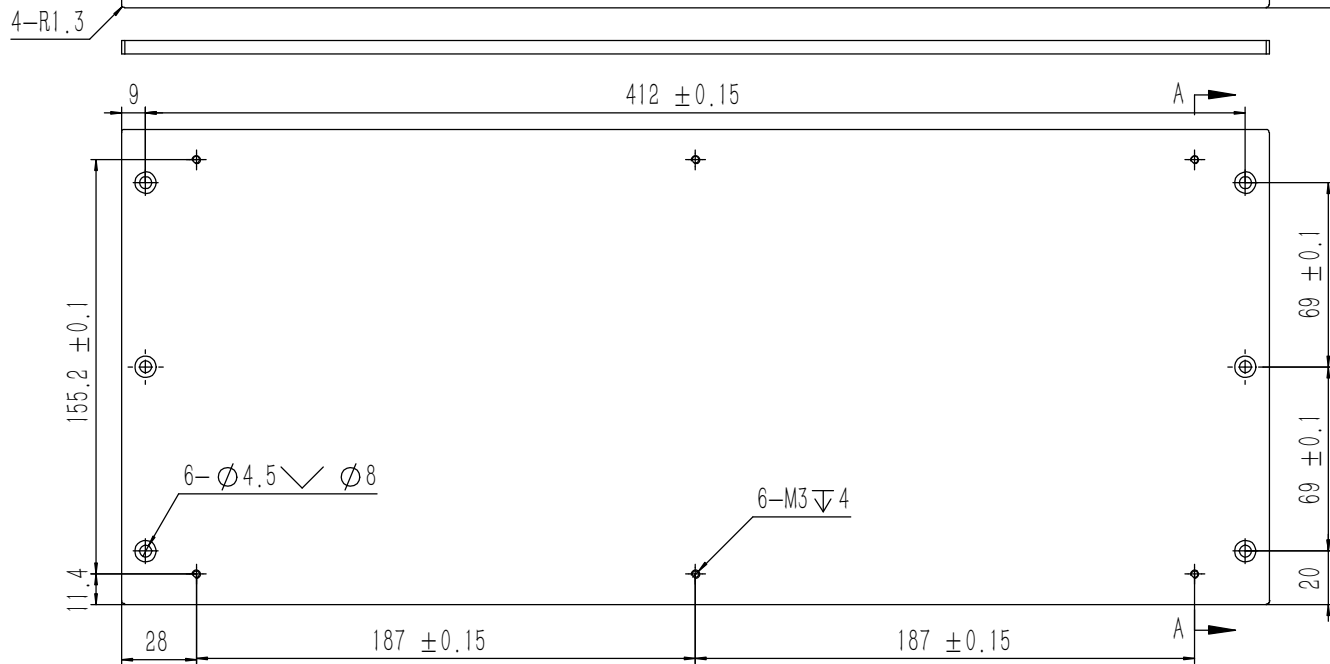
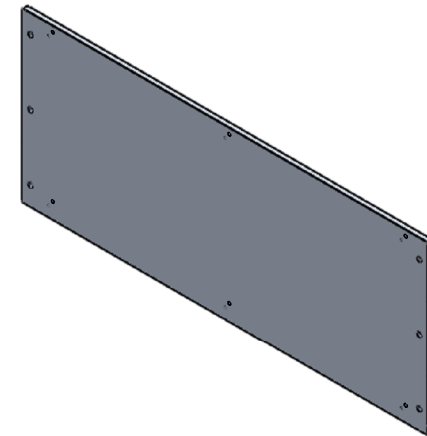

- 技术要求:
- 1、零件加工表面不应有划痕、擦伤等损伤零件表面的缺陷;
 - 2、去除毛刺飞边, 锐角倒钝;
 - 3、未标注尺寸见3D数模。

Tolerances (未注公差): 0.5 to 6 ± 0.1 6 to 30 ± 0.2 30 to 120 ± 0.3 120 to 400 ± 0.4	Material (材料):	5052-H32	
	Weight: (重量) (Kg):	1.024	
Break sharp edges (未注锐边倒角): Ch 0.05 to 0.25 x45°	Protection: (表面处理):		
	Position tolerances (未注位置公差): ± 0.05	Part Name (零/部件名称):	后面板
Angular tolerances (未注角度公差): <6° ± 10' <30° ± 20' <120° ± 30' >120° ± 1°	Signature by (批准):	Date (日期):	2020.05.27
	Signature by (批准):	Date (日期):	
Drawing Number (图号):		YG-C24B-0000-002	
Drawn by (绘图):	莫永康	Size: (图幅):	A1
Check by (校对):		Scale (比例):	1:1
Revision (版本):	A1	Sheet (页数):	1 / 1

