

技术要求:

- 1、必须按照设计、工艺要求及本规定和有关标准进行装配;
- 2、所有零部件(包括外购、外协件)必须具有检验合格证方能进行装配;
- 3、零件在装配前必须清理和清洗干净,不得有毛刺、飞边、氧化皮、锈蚀、切屑、砂粒、灰尘和油污等,并应符合相应清洁度要求;
- 4、装配过程中零件不得磕碰、划伤和锈蚀;
- 5、油漆未干的零件不得进行装配;
- 6、相对运动的零件,装配时接触面间应加润滑油脂;
- 7、各零、部件装配后相对位置应准确。

4	GB-T-819.1-2000-C-NI-M3X8	碳钢镀镍十字沉头螺丝M3X8	普通碳钢	8	0.0005	
3	YG-K08B-0000-003	挡板	5052-H32	2	0.025	
2	YG-K08B01-0000-002	K08B红色塑料防护框	ABS	2	0.021	
1	YG-K08B-0000-001	壳体	6063-T5	2	0.119	
序号	图号	名称	材料	数量	单重	备注

Tolerances (未注公差): 0.5 to 6 ± 0.1 6 to 30 ± 0.2 30 to 120 ± 0.3 120 to 400 ± 0.4		Material (材料): (装配图)		YONGU 永固	
Angular tolerances (未注角度公差): <6° ± 10' <30° ± 20' <120° ± 30' >120° ± 1°		Weight: (重量) (Kg) 0.334			
Break sharp edges (未注锐边倒角): Ch 0.05 to 0.25 x45°		Protection: (表面处理):			
Position tolerances (未注位置公差): ±0.05		Part Name (零/部件名称): K08B防护壳体		Drawing Number (图号): YG-K08B-0000-000	
		Drawn by (绘图): 许宏彬		Date (日期): 2020.05.09	
		Check by (校对):		Date (日期):	
		Signature by (批准):		Date (日期):	
		Size (图幅): A3		Scale (比例): 1:1	
		Revision (版本): A1		Sheet (页数): 1 / 1	

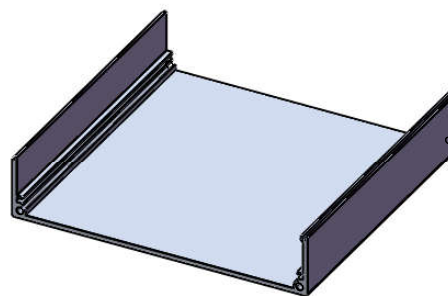
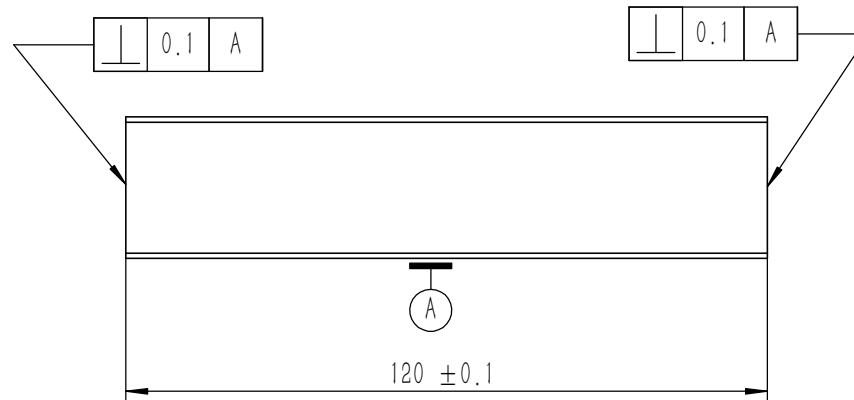
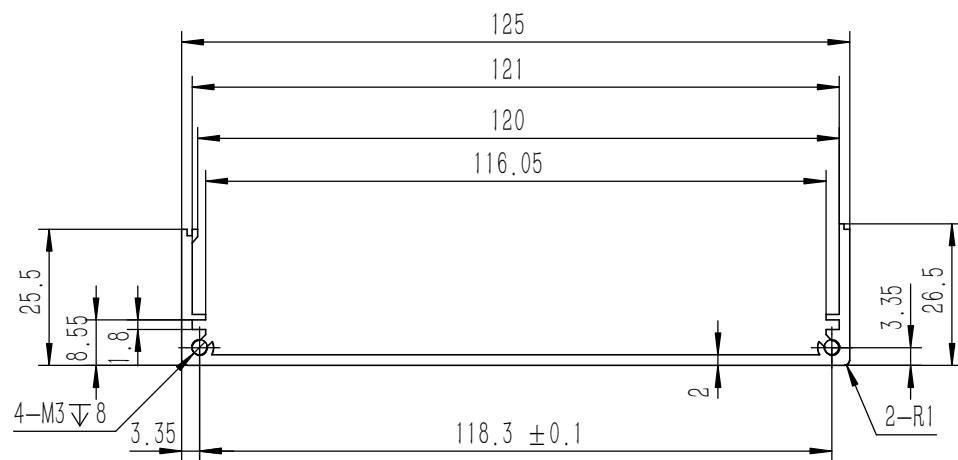

技术要求:

- 1、零件加工表面不应有划痕、擦伤等损伤零件表面的缺陷;
- 2、去除毛刺飞边, 锐角倒钝;
- 3、未标注尺寸见3D数模。

Tolerances (未注公差): 0.5 to 6 ± 0.1 6 to 30 ± 0.2 30 to 120 ± 0.3 120 to 400 ± 0.4	Material (材料):	6063-T5		YONGU 永固
	Weight: (重量) (Kg)	0.119		
Break sharp edges (未注锐边倒角): Ch 0.05 to 0.25 x45°	Protection: (表面处理):	Part Name (零/部件名称):		Drawing Number (图号):
Angular tolerances (未注角度公差): <6° ± 10' <30° ± 20' <120° ± 30' >120° ± 1°	壳 体		YG-K08B-0000-001	
Position tolerances (未注位置公差): ±0.05	Drawn by (绘图):	Date (日期):	Size: (图幅):	 Sheet (页数): 1 / 1
	许宏彬	2020.05.09	A3	
	Check by (校对):	Date (日期):	Scale (比例): 1:1	
	Signature by (批准):	Date (日期):	Revision (版本): A1	

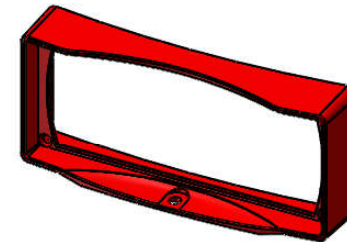
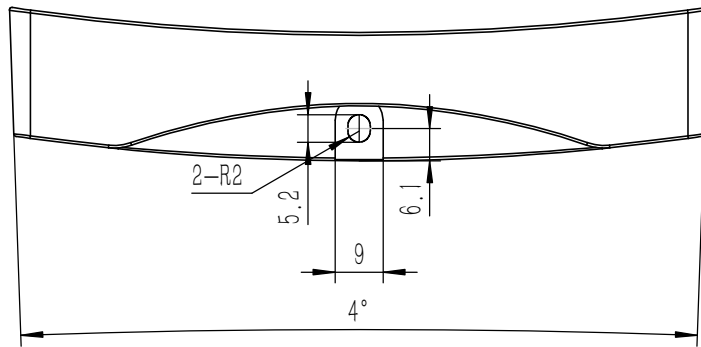
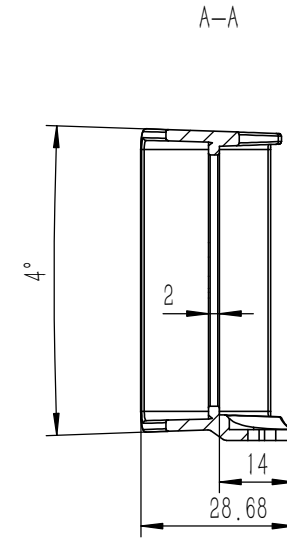
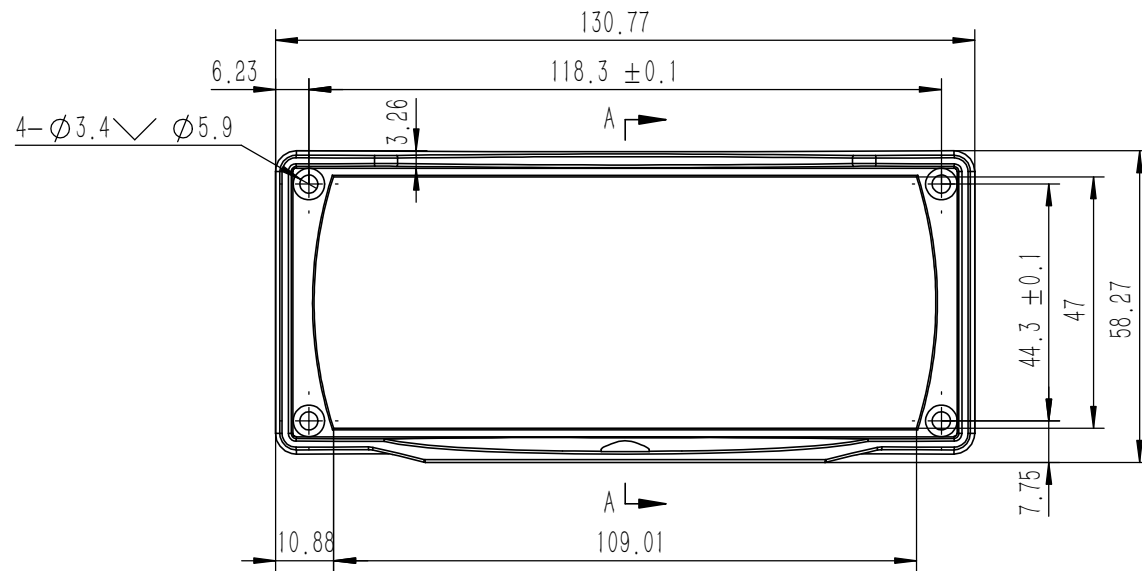

技术要求:

- 1、零件加工表面不应有划痕、擦伤等损伤零件表面的缺陷;
- 2、去除毛刺飞边, 锐角倒钝;
- 3、未标注尺寸见3D数模。

Tolerances (未注公差): 0.5 to 6 ± 0.1 6 to 30 ± 0.2 30 to 120 ± 0.3 120 to 400 ± 0.4	Material (材料):	ABS	YONGU 永固
	Weight: (重量) (Kg)	0.021	
Break sharp edges (未注锐边倒角): Ch 0.05 to 0.25 x45°	Protection: (表面处理):	喷橡胶漆	Drawing Number (图号): YG-K08B01-0000-002
	Angular tolerances (未注角度公差): <6° ± 10' <30° ± 20' <120° ± 30' >120° ± 1°	Part Name (零/部件名称):	
Position tolerances (未注位置公差): ±0.05	Part Name (零/部件名称):	K08B红色塑料防护框	Size (图幅): A3
	Drawn by (绘图): 许宏彬	Date (日期): 2020.05.09	
	Check by (校对):	Date (日期):	Scale (比例): 1:1
	Signature by (批准):	Date (日期):	Revision (版本): A1

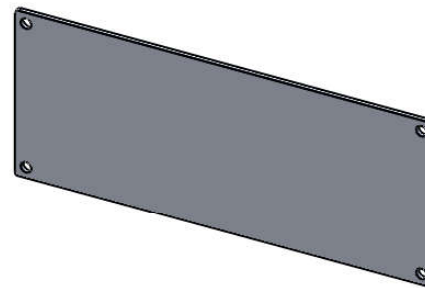
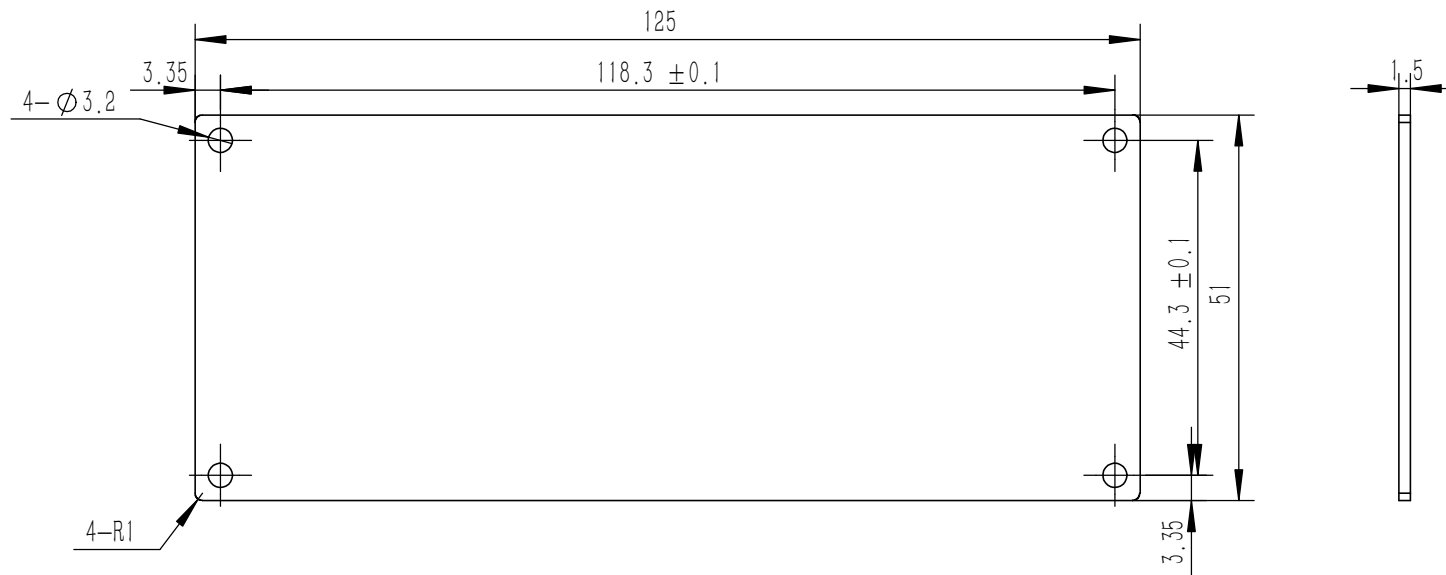

技术要求:

- 1、零件加工表面不应有划痕、擦伤等损伤零件表面的缺陷;
- 2、去除毛刺飞边, 锐角倒钝;
- 3、未标注尺寸见3D数模。

Tolerances (未注公差): 0.5 to 6 ± 0.1 6 to 30 ± 0.2 30 to 120 ± 0.3 120 to 400 ± 0.4	Material (材料):	5052-H32	
	Weight: (重量) (Kg)	0.025	
Break sharp edges (未注锐边倒角): Ch 0.05 to 0.25 x45°	Protection: (表面处理):		
	Angular tolerances (未注角度公差): <6° ± 10' <30° ± 20' <120° ± 30' >120° ± 1°	Part Name (零/部件名称):	挡板
Position tolerances (未注位置公差): ±0.05	Drawn by (绘图):	许宏彬	Date (日期):
	Check by (校对):		Date (日期):
	Signature by (批准):		Date (日期):
	Drawing Number (图号):		YG-K08B-0000-003
	Size: (图幅):	A4	Sheet (页数):
	Scale (比例):	1:1	
	Revision (版本):	A1	1 / 1

YONGU 永固