

技术要求:

- 1、必须按照设计、工艺要求及本规定和有关标准进行装配;
- 2、所有零部件(包括外购、外协件)必须具有检验合格证方能进行装配;
- 3、零件在装配前必须清理和清洗干净,不得有毛刺、飞边、氧化皮、锈蚀、切屑、砂粒、灰尘和油污等,并应符合相应清洁度要求;
- 4、装配过程中零件不得磕碰、划伤和锈蚀;
- 5、油漆未干的零件不得进行装配;
- 6、相对运动的零件,装配时接触面间应加润滑油脂;
- 7、各零、部件装配后相对位置应准确。

4	GB-T-819.1-2000-C-NI-M3X6	碳钢镀镍十字沉头螺丝M3X6	普通碳钢	8	0.0004	
3	YG-H55A-0000-001	壳体1	6063-T5	1	0.140	
2	YG-H55A-0000-003	挡板	5052-H32	2	0.017	
1	YG-H55A-0000-002	壳体2	6063-T5	1	0.359	
序号 (Item)	图号 (Drawing Number)	名称 (Part Name)	材料 (Material)	数量 (QTY)	单重 (Weight)	备注 (Note)

Tolerances (未注公差):		Material (材料): (装配图)			
0.5 to 6 ± 0.1		Weight: (重量) (Kg) 0.537			
6 to 30 ± 0.2		Protection: (表面处理):			
30 to 120 ± 0.3		Part Name (零/部件名称):		Drawing Number (图号):	
120 to 400 ± 0.4		H55A壳体		YG-H55A-0000-000	
Break sharp edges (未注锐边倒角): Ch 0.05 to 0.25 x45°		Angular tolerances (未注角度公差):		Drawn by (绘图): 邓宏博	
<6° ± 10'		<6° ± 10'		Date (日期): 2020.06.17	
<30° ± 20'		<30° ± 20'		Size (图幅): A3	
<120° ± 30'		<120° ± 30'		Check by (校对):	
± 0.05		>120° ± 1°		Date (日期):	
				Signature by (批准):	
				Date (日期):	
				Scale (比例): 1:1	
				Revision (版本): A1	
				Sheet (页数): 1 / 1	

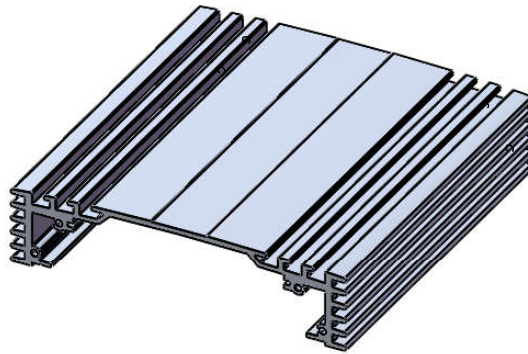
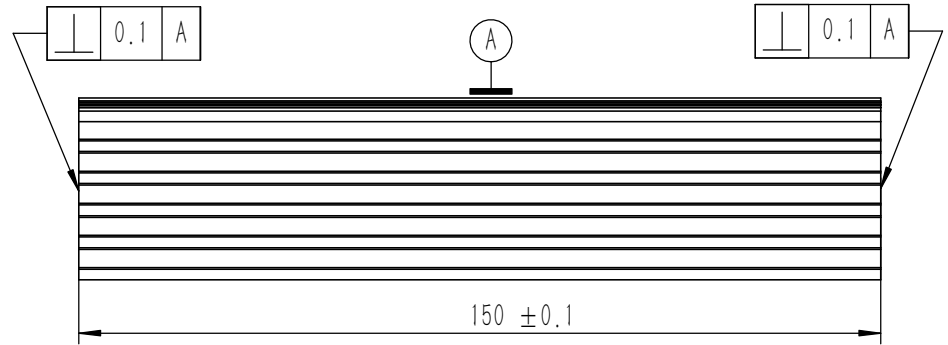
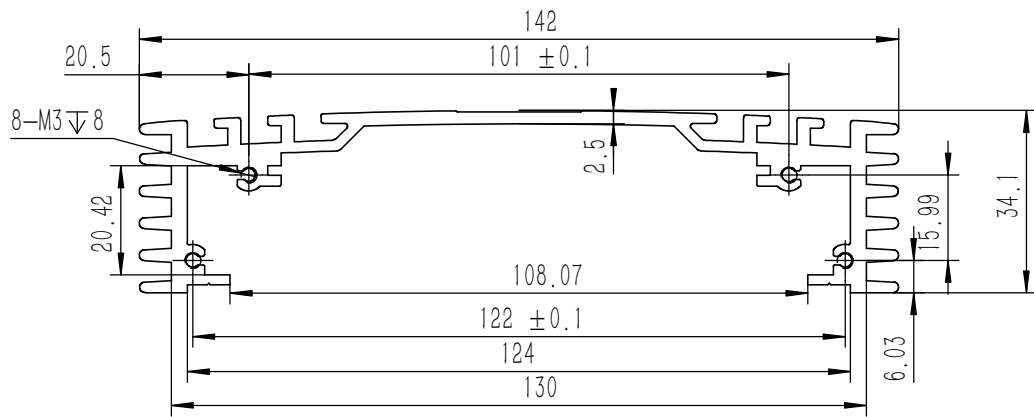

技术要求:

- 1、零件加工表面不应有划痕、擦伤等损伤零件表面的缺陷;
- 2、去除毛刺飞边, 锐角倒钝;
- 3、未标注尺寸见3D数模。

Tolerances (未注公差): 0.5 to 6 ± 0.1 6 to 30 ± 0.2 30 to 120 ± 0.3 120 to 400 ± 0.4	Material (材料):	6063-T5		YONGU 永固
	Weight: (重量) (Kg)	0.359		
Break sharp edges (未注锐边倒角): Ch 0.05 to 0.25 x45°	Protection: (表面处理):			Drawing Number (图号): YG-H55A-0000-002
	Position tolerances (未注位置公差): ±0.05	Part Name (零/部件名称):	壳体2	
Angular tolerances (未注角度公差): <6° ± 10' <30° ± 20' <120° ± 30' >120° ± 1°	Part Name (零/部件名称):	壳体2		Size (图幅): A3
	Drawn by (绘图): 邓宏博	Date (日期): 2020.06.17	Sheet (页数): 1 / 1	
	Check by (校对):	Date (日期):	Scale (比例): 1:1	Revision (版本): A1
	Signature by (批准):	Date (日期):		

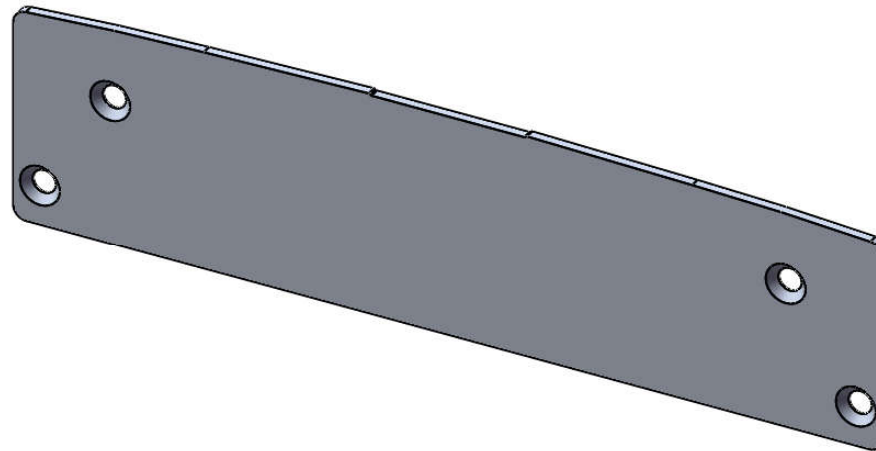
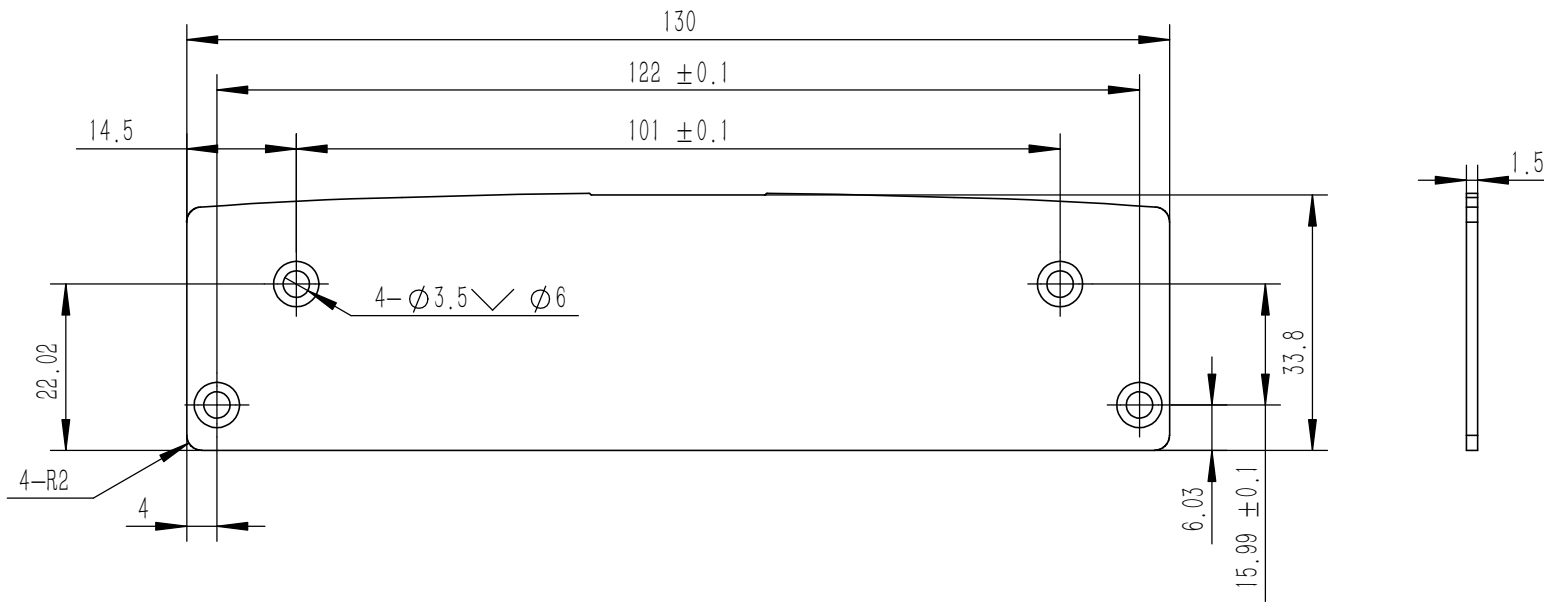

技术要求:

- 1、零件加工表面不应有划痕、擦伤等损伤零件表面的缺陷;
- 2、去除毛刺飞边, 锐角倒钝;
- 3、未标注尺寸见3D数模。

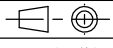
Tolerances (未注公差): 0.5 to 6 ± 0.1 6 to 30 ± 0.2 30 to 120 ± 0.3 120 to 400 ± 0.4	Material (材料):	5052-H32		YONGU 
	Weight: (重量) (Kg)	0.017		
Break sharp edges (未注锐边倒角): Ch 0.05 to 0.25 x45°	Protection: (表面处理):			Drawing Number (图号): YG-H55A-0000-003
	Position tolerances (未注位置公差): ±0.05	Part Name (零/部件名称):	挡板	
Angular tolerances (未注角度公差): <6° ± 10' <30° ± 20' <120° ± 30' >120° ± 1°	Part Name (零/部件名称):	挡板		Scale (比例): A4
	Drawn by (绘图): 邓宏博	Date (日期): 2020.06.17	Sheet (页数): 	
	Check by (校对):	Date (日期):	Scale (比例): 1:1	Sheet (页数): 1 / 1
	Signature by (批准):	Date (日期):	Revision (版本): A1	

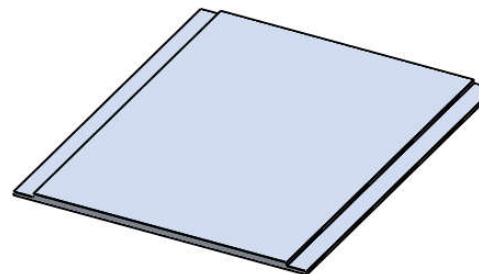
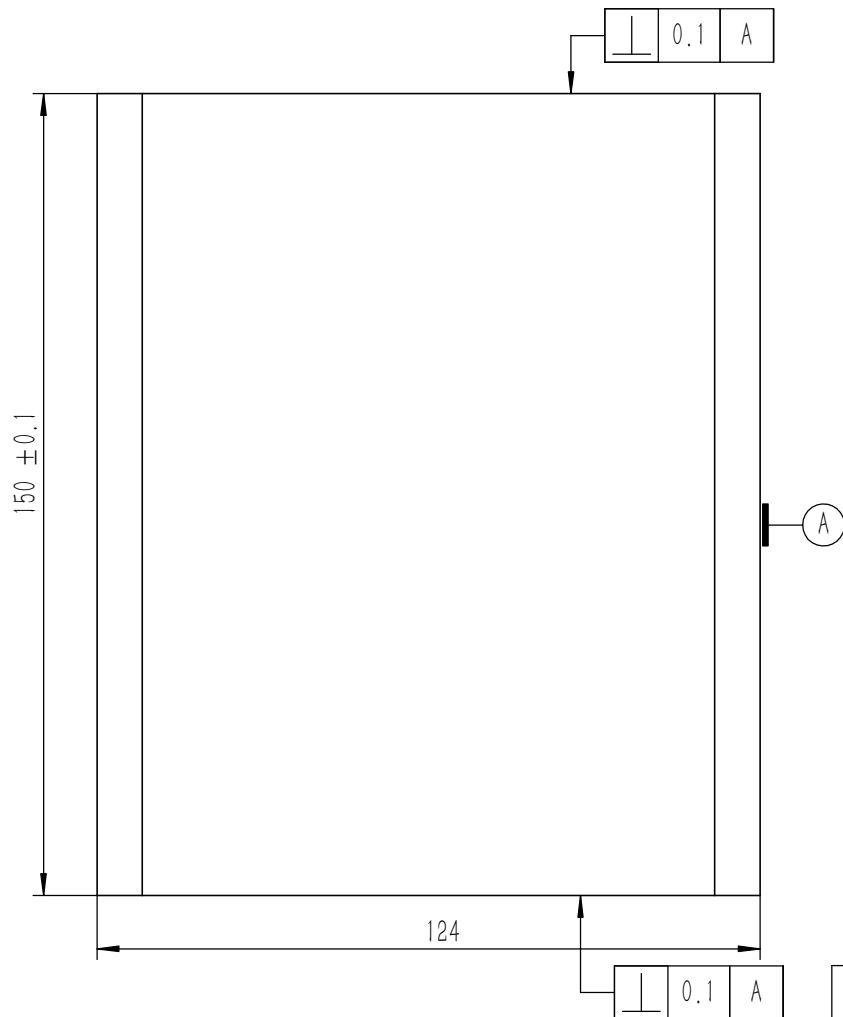
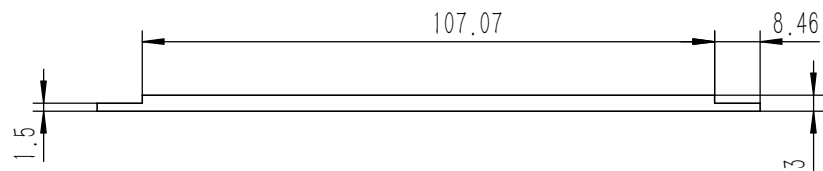

技术要求:

- 1、零件加工表面不应有划痕、擦伤等损伤零件表面的缺陷;
- 2、去除毛刺飞边, 锐角倒钝;
- 3、未标注尺寸见3D数模。

Break sharp edges (未注锐边倒角): Ch 0.05 to 0.25 x45°	Angular tolerances (未注角度公差): <6° ± 10' <30° ± 20' <120° ± 30' >120° ± 1°
Position tolerances (未注位置公差): ±0.05	

Tolerances (未注公差): 0.5 to 6 ± 0.1 6 to 30 ± 0.2 30 to 120 ± 0.3 120 to 400 ± 0.4	Material (材料): 6063-T5	YONGU 永固
	Weight: (重量) (Kg) 0.140	
Protection: (表面处理):	Part Name (零/部件名称): 壳体1	Drawing Number (图号): YG-H55A-0000-001
Drawn by (绘图): 邓宏博	Date (日期): 2020.06.17	Size (图幅): A3
Check by (校对):	Date (日期):	Scale (比例): 1:1
Signature by (批准):	Date (日期):	Revision (版本): A1

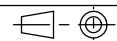

Sheet (页数):

1 / 1