

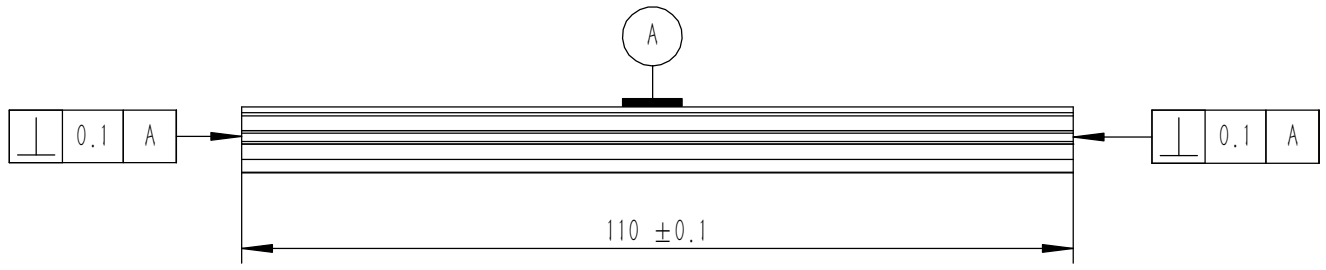

22	DIN-9250-S-NL-M3	不锈钢防松垫圈	SUS 304	8	0.000	
21	YG-TY-A13-011	A垫板	5052-H32	1	0.594	
20	YG-TY-XJD-001	自粘胶垫35X11X3	硅橡胶	8	0.0013	
19	GB-T-70.3-2000-C-NI-M3X6	芳生镀白镍内六角沉头螺丝M3X6	普通碳钢	16	0.0004	
18	YG-TY-A12-010	前后面板-115H	5052-H32	2	0.764	
17	YG-TY-A07-002	后防护条-115H	5052-H32	2	0.048	
16	YG-TY-A11-003	面板下固定件3	电解板	2	0.067	
15	GB-T-973-1976-C-NI-M3X12	碳钢镀镍十字大扁头螺丝M3X12	普通碳钢	16	0.001	
14	S-M3-1-ZI	压铆螺母镀锌M3X1	普通碳钢	8	0.3750	
13	GB-T-973-1976-C-NI-M3X4	碳钢镀镍十字大扁头螺丝M3X4	普通碳钢	42	0.0005	
12	BSO-M3-5-ZI-D5.4	压铆螺母 M3X5	普通碳钢	10	0.001	
11	YG-TY-B01-011	上下盖板	5052-H32	1	1.046	
10	YG-TY-B05-002	B包角2	6063-T5	4	0.035	
9	GB-T-973-1976-C-NI-M3X6	碳钢镀镍十字大扁头螺丝M3X6	普通碳钢	16	0.0006	
8	YG-TY-A06-002	拉手-115H	6063-T5	2	0.092	
7	YG-TY-A10-003	面板上固定件3	电解板	2	0.061	
6	YG-TY-B05-001	B包角1	6063-T5	4	0.035	
5	YG-TY-A08-002	A侧板固定件115H	6063-T5	4	0.041	
4	YG-TY-B03-002	B组合侧板	6063-T5	6	0.161	
3	YG-TY-B02-011	上盖板	5052-H32	1	1.008	
2	YG-TY-A09-002	侧板连接件	电解板	6	0.030	
1	YG-TY-B04-002	B组合侧板	6063-T5	2	0.089	
序号	图号	名称	材料	数量	单重	备注

- 技术要求:
- 1、必须按照设计、工艺要求及本规定和有关标准进行装配;
 - 2、所有零部件(包括外购、外协件)必须具有检验合格证方能进行装配;
 - 3、零件在装配前必须清理和清洗干净,不得有毛刺、飞边、氧化皮、锈蚀、切屑、砂粒、灰尘和油污等,并应符合相应清洁度要求;
 - 4、装配过程中零件不得磕碰、划伤和锈蚀;
 - 5、油漆未干的零件不得进行装配;
 - 6、相对运动的零件,装配时接触面间应加润滑油脂;
 - 7、各零、部件装配后相对位置应准确。

Tolerances (未注公差): 0.5 to 6 ± 0.1 6 to 30 ± 0.2 30 to 120 ± 0.3 120 to 400 ± 0.4	Material (材料): (装配图)	YONGU 永固	Drawing Number (图号): YG-B10-1000-000			
	Weight: (重量) (Kg): 6.553		Size: (图幅): A0			
Break sharp edges (未注锐边倒角): Ch 0.05 to 0.25 x45°	Protection: (表面处理):	B10机箱	Scale (比例): 1:1.5			
	Part Name (零/部件名称):		Sheet (页数): 1 / 1			
Angular tolerances (未注角度公差): <6° ± 10' <30° ± 20' <120° ± 30' >120° ± 1°	Position tolerances (未注位置公差): ± 0.05	Drawn by (绘图): 邓展锋	Date (日期): 2020.05.22	Signature by (校对):	Date (日期):	Revision (版本): A1

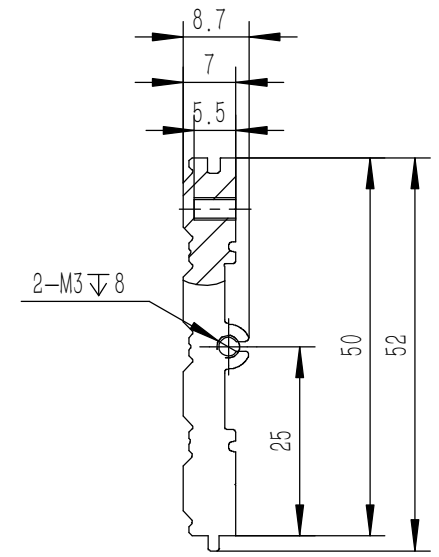
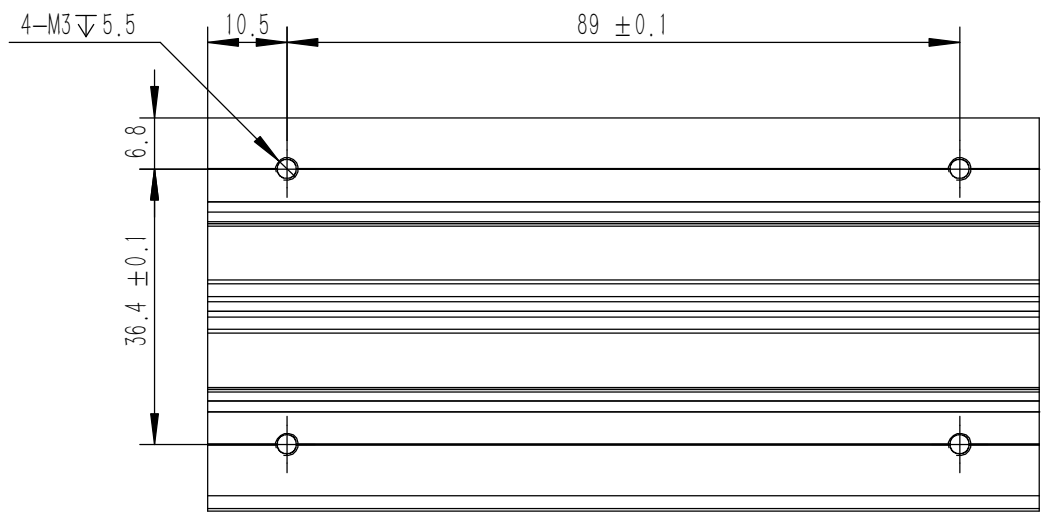

技术要求:
 1、零件加工表面不应有划痕、擦伤等损伤零件表面的缺陷;
 2、去除毛刺飞边,锐角倒钝;
 3、未标注尺寸见3D数模。

Tolerances (未注公差): 0.5 to 6 ± 0.1 6 to 30 ± 0.2 30 to 120 ± 0.3 120 to 400 ± 0.4	Material (材料):	6063-T5		YONGU 
	Weight: (重量) (Kg)	0.089		
Break sharp edges (未注锐边倒角): Ch 0.05 to 0.25 x45°	Protection: (表面处理):			Drawing Number (图号): YG-TY-B04-002
	Position tolerances (未注位置公差): ±0.05	Part Name (零/部件名称):	B组合侧板	
Angular tolerances (未注角度公差): <6° ± 10' <30° ± 20' <120° ± 30' >120° ± 1°	Part Name (零/部件名称):	B组合侧板		Size: (图幅): A4 Sheet (页数): 1 / 1
	Drawn by (绘图):	邓展锋	Date (日期): 2020.05.19	
	Check by (校对):		Date (日期):	
	Signature by (批准):		Date (日期):	Revision (版本): A1

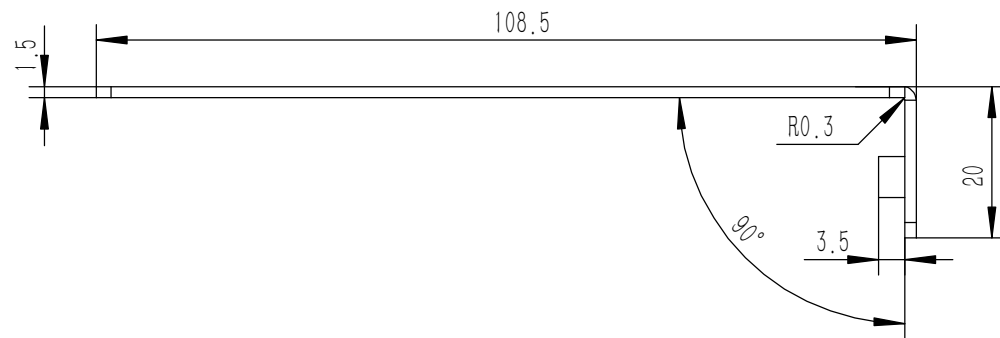
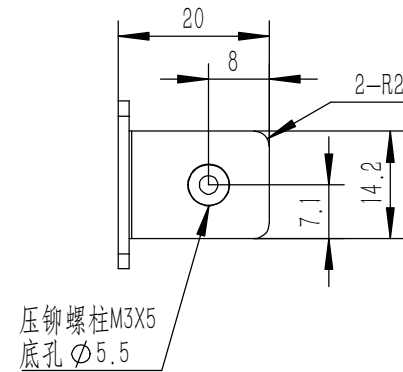
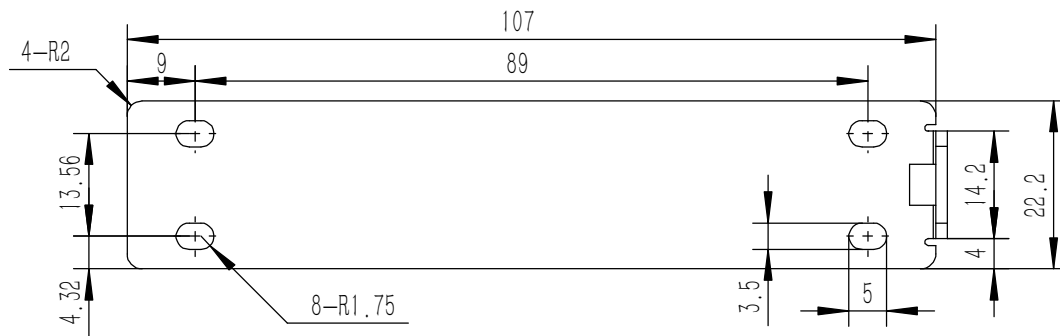

钣金展开及折弯方向参考图 (视图比例1:1)

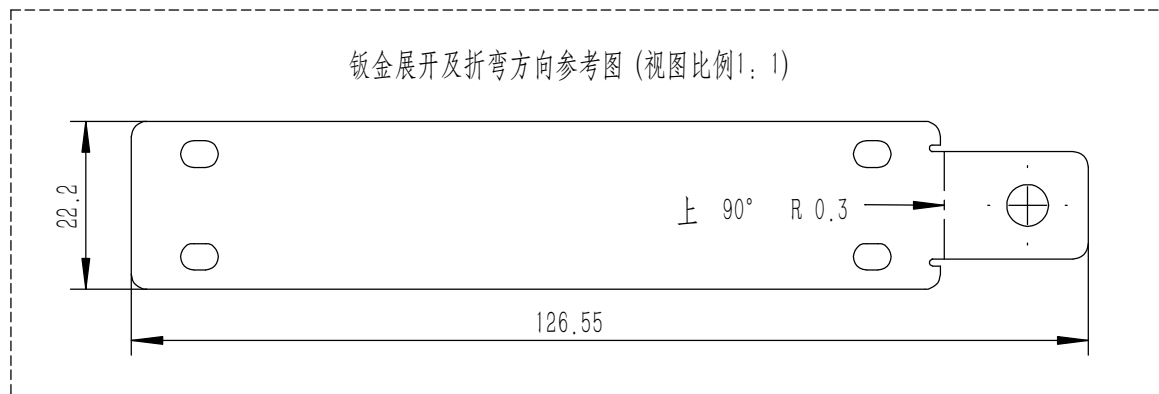

技术要求:

- 1、零件加工表面不应有划痕、擦伤等损伤零件表面的缺陷;
- 2、去除毛刺飞边, 锐角倒钝;
- 3、未标注尺寸见3D数模。

Tolerances (未注公差): 0.5 to 6 ± 0.1 6 to 30 ± 0.2 30 to 120 ± 0.3 120 to 400 ± 0.4	Material (材料):	电解板	
	Weight: (重量) (Kg)	0.031	
Break sharp edges (未注锐边倒角): Ch 0.05 to 0.25 x45°	Protection: (表面处理):		
	Position tolerances (未注位置公差): ±0.05	Part Name (零/部件名称):	侧板连接件 115H
Angular tolerances (未注角度公差): <6° ± 10' <30° ± 20' <120° ± 30' >120° ± 1°	Part Name (零/部件名称):	侧板连接件 115H	
	Drawn by (绘图):	Date (日期):	2020.05.19
Drawing Number (图号): YG-TY-A09-002	Check by (校对):	Date (日期):	
	Signature by (批准):	Date (日期):	
Size: (图幅): A4		Drawing Number (图号): YG-TY-A09-002	
Scale (比例): 1:1		Sheet (页数): 1 / 1	
Revision (版本): A1			

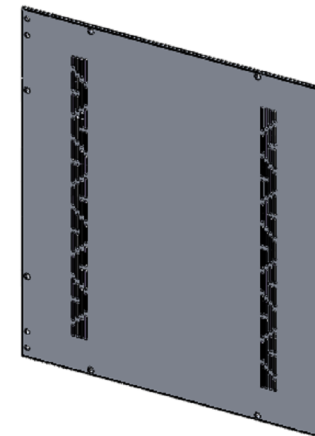
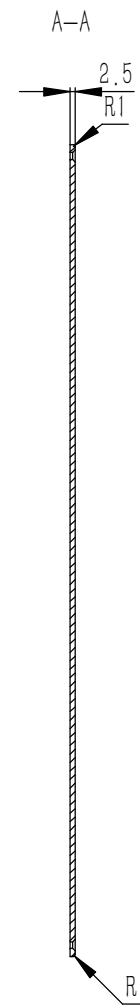
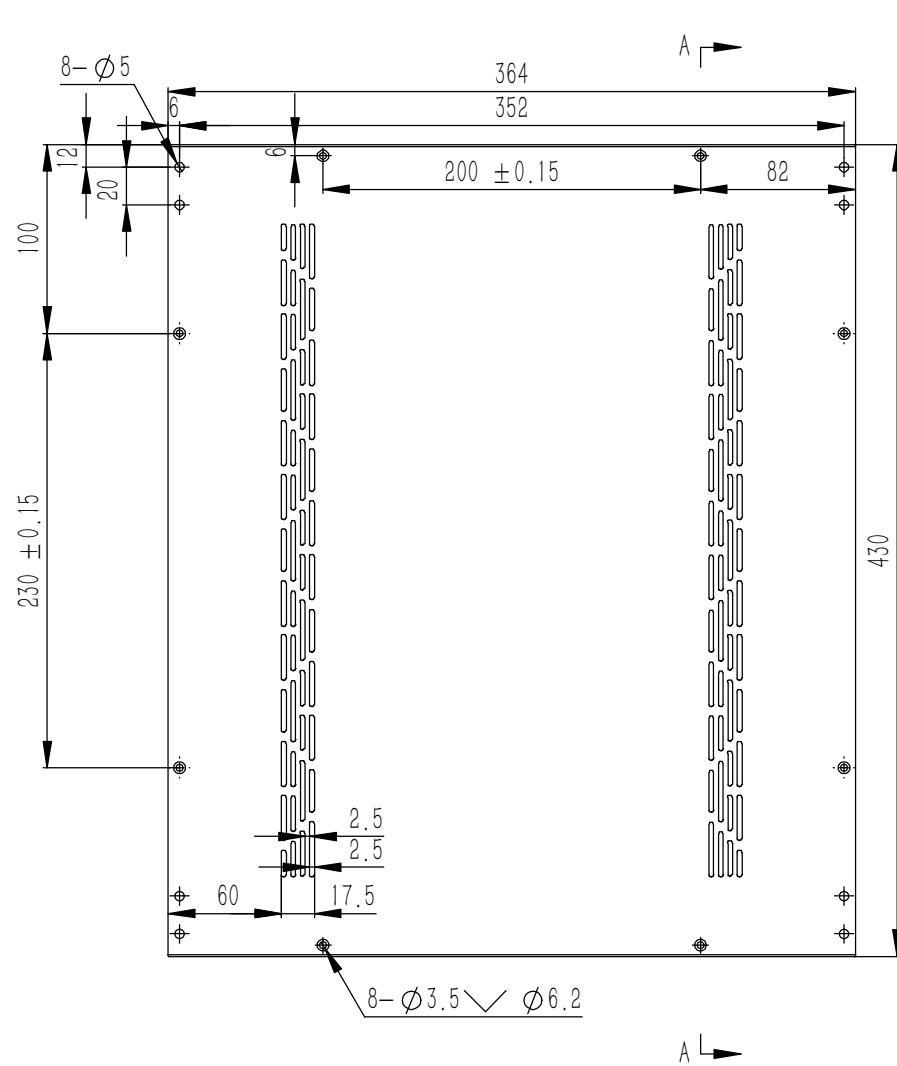

技术要求:

- 1、零件加工表面不应有划痕、擦伤等损伤零件表面的缺陷;
- 2、去除毛刺飞边,锐角倒钝;
- 3、未标注尺寸见3D数模。

Break sharp edges (未注锐边倒角): Ch 0.05 to 0.25 x45°	Angular tolerances (未注角度公差): <6° ± 10' <30° ± 20' <120° ± 30' >120° ± 1°
Position tolerances (未注位置公差): ± 0.05	

Tolerances (未注公差): 0.5 to 6 ± 0.1 6 to 30 ± 0.2 30 to 120 ± 0.3 120 to 400 ± 0.4	Material (材料):	5052-H32		YONGU 永固
	Weight: (重量) (Kg):	1.008		
	Protection: (表面处理):			
	Part Name (零/部件名称):	上盖板		Drawing Number (图号): YG-TY-B02-011
Drawn by (绘图): 邓展锋	Date (日期): 2020.05.18	Size (图幅): A0	Sheet (页数): 1 / 1	
Check by (校对):	Date (日期):	Scale (比例): 1:1	Revision (版本): A1	
Signature by (批准):	Date (日期):			

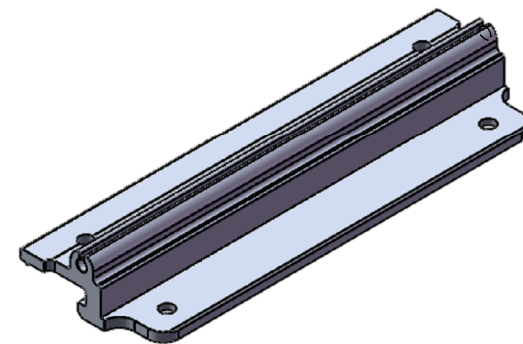
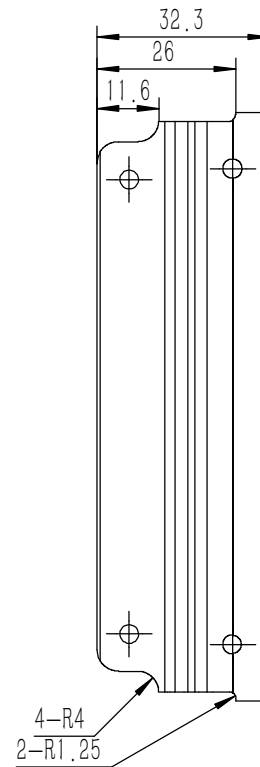
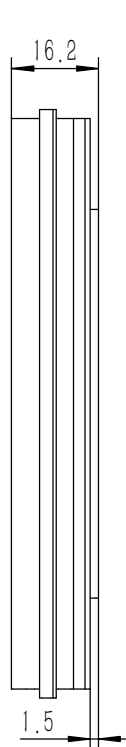
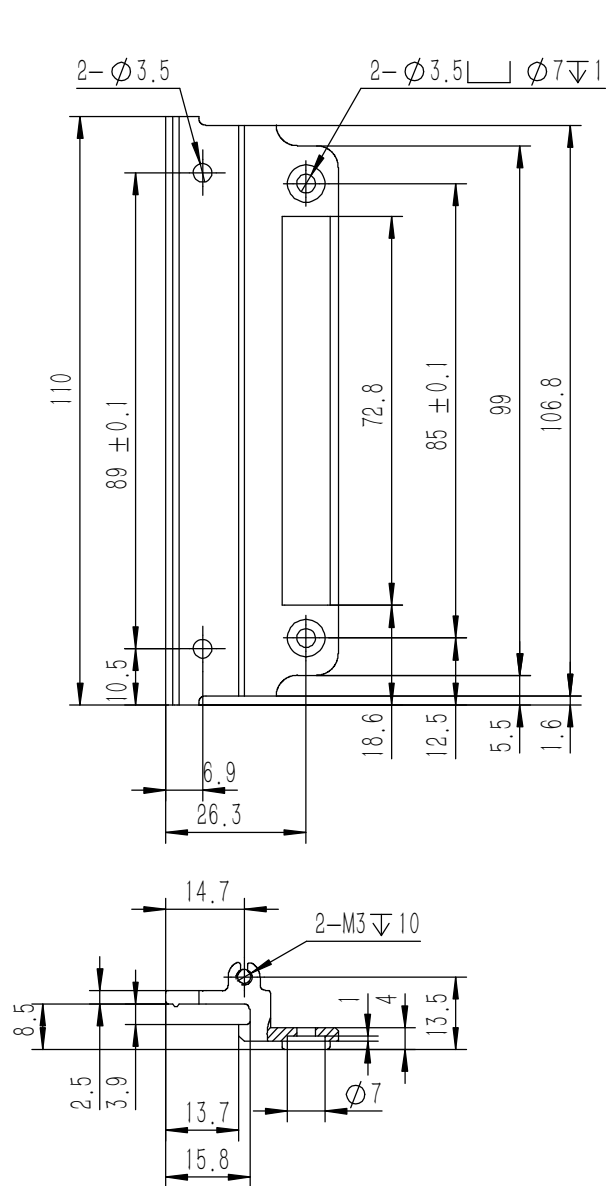

技术要求:

- 1、零件加工表面不应有划痕、擦伤等损伤零件表面的缺陷;
- 2、去除毛刺飞边, 锐角倒钝;
- 3、未标注尺寸见3D数模。

Break sharp edges (未注锐边倒角): Ch 0.05 to 0.25 x45°	Angular tolerances (未注角度公差): <6° ± 10' <30° ± 20' <120° ± 30' >120° ± 1°
Position tolerances (未注位置公差): ±0.05	

Tolerances (未注公差): 0.5 to 6 ± 0.1 6 to 30 ± 0.2 30 to 120 ± 0.3 120 to 400 ± 0.4	Material (材料): 6063-T5	YONGU 永固
	Weight: (重量) (Kg) 0.041	
	Protection: (表面处理):	
	Part Name (零/部件名称): A侧板固定件115H	Drawing Number (图号): YG-TY-A08-002
	Drawn by (绘图): 邓展锋	Date (日期): 2020.05.18
	Check by (校对):	Date (日期):
	Signature by (批准):	Date (日期):
	Size (图幅): A3	Scale (比例): 1:1
	Revision (版本): A1	Sheet (页数): 1 / 1

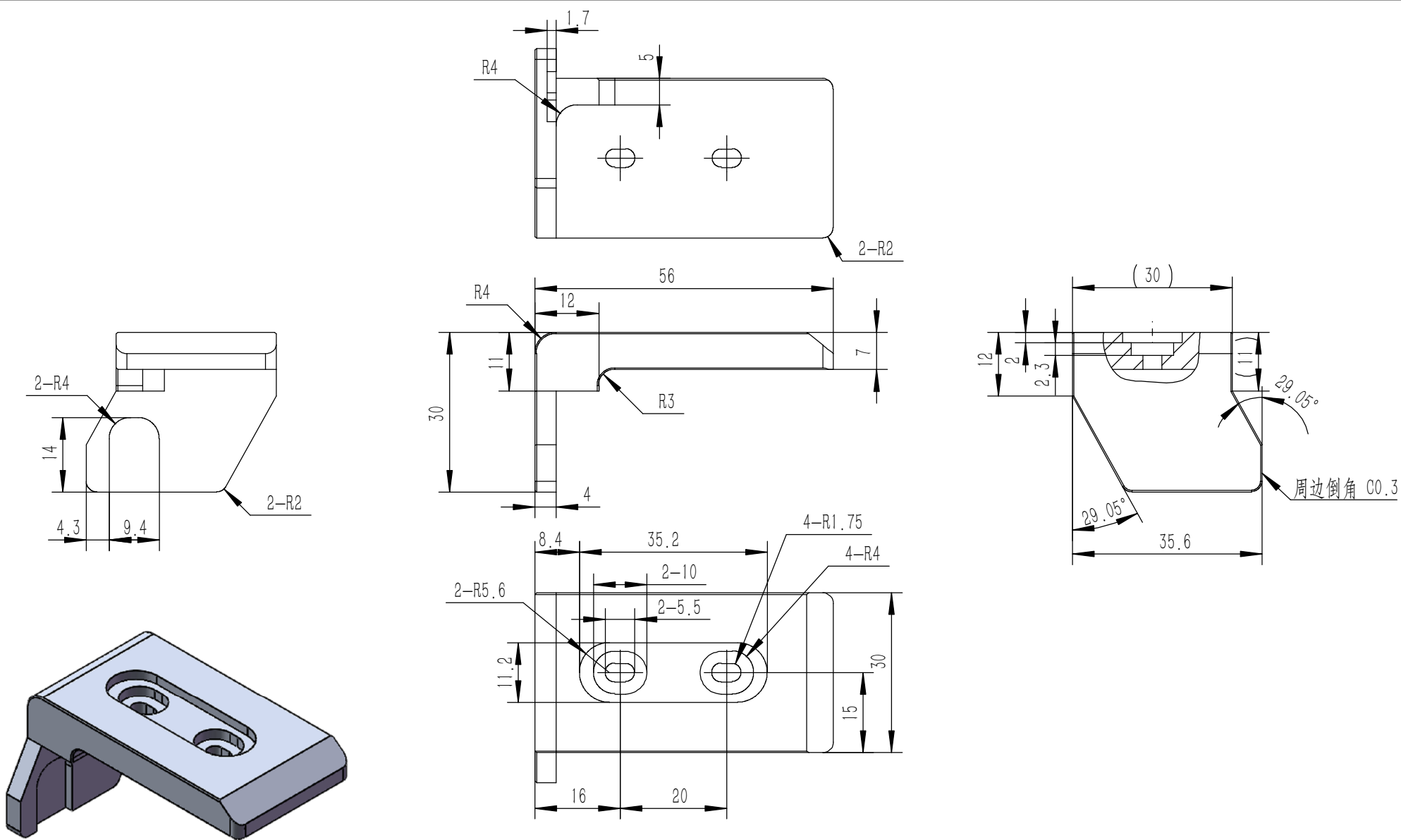

技术要求:
 1、零件加工表面不应有划痕、擦伤等损伤零件表面的缺陷;
 2、去除毛刺飞边,锐角倒钝;
 3、未标注尺寸见3D数模。

Tolerances (未注公差): 0.5 to 6 ± 0.1 6 to 30 ± 0.2 30 to 120 ± 0.3 120 to 400 ± 0.4	Material (材料):	6063-T5	
	Weight: (重量) (Kg)	0.035	
Break sharp edges (未注锐边倒角): Ch 0.05 to 0.25 x45° Position tolerances (未注位置公差): ±0.05	Protection: (表面处理):		
	Part Name (零/部件名称):	B包角1	
Angular tolerances (未注角度公差): <6° ± 10' <30° ± 20' <120° ± 30' >120° ± 1°	Part Name (零/部件名称):	B包角1	
	Drawing Number (图号):	YG-TY-B05-001	
Drawn by (绘图):	Date (日期):	2020.05.18	Size: (图幅): A4
Check by (校对):	Date (日期):		Scale (比例): 1:1
Signature by (批准):	Date (日期):		Revision (版本): A1
			Sheet (页数): 1 / 1



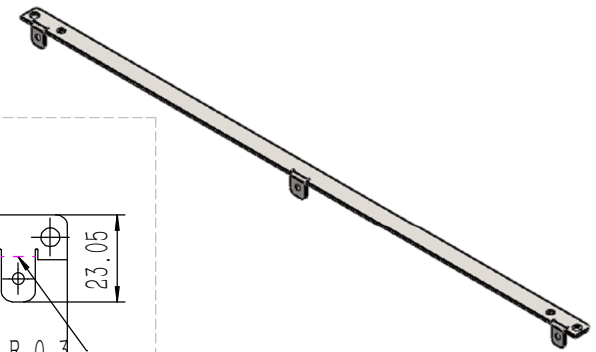
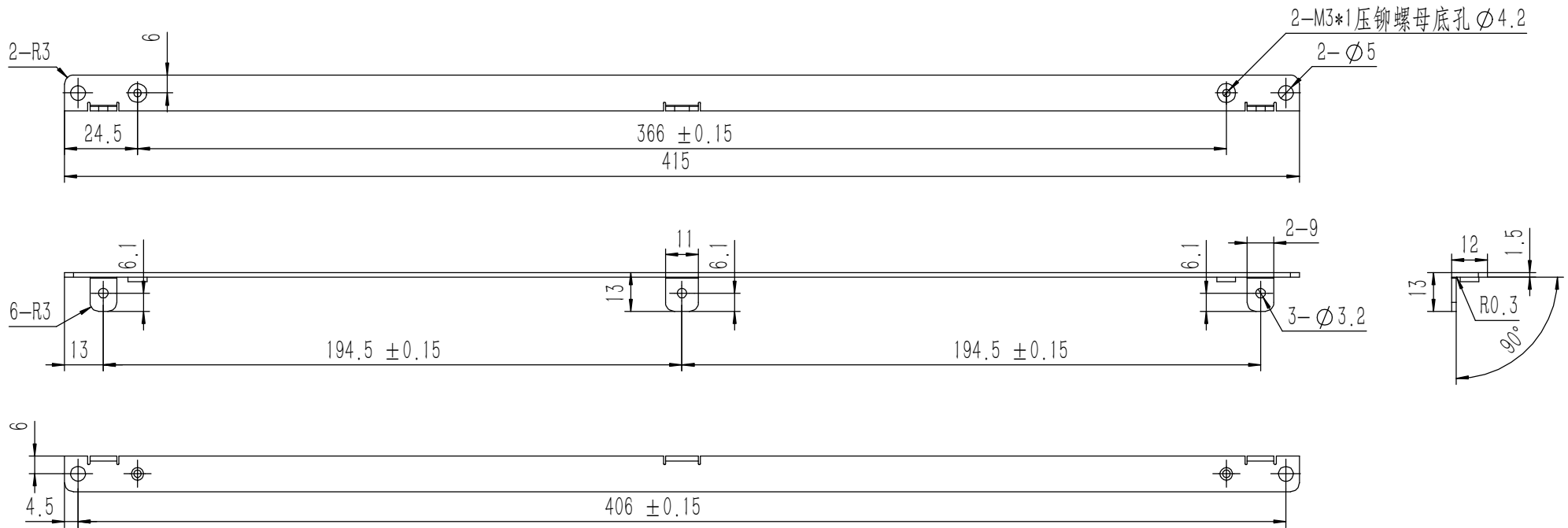

钣金展开及折弯方向参考图 (视图比例1:1)

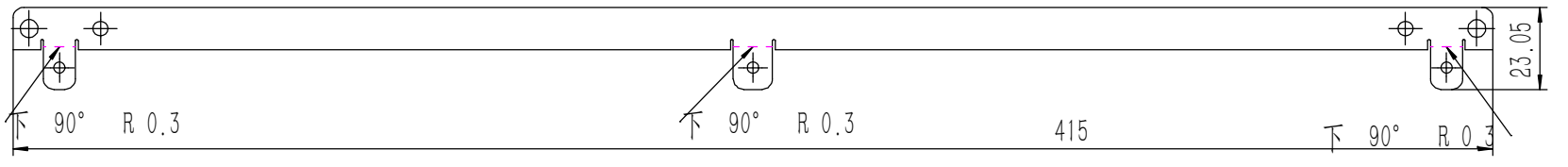

业务代码:

技术要求:

- 1、零件加工表面不应有划痕、擦伤等损伤零件表面的缺陷;
- 2、去除毛刺飞边, 锐角倒钝;
- 3、未标注尺寸见3D数模。

Tolerances (未注公差): 0.5 to 6 ± 0.1 6 to 30 ± 0.2 30 to 120 ± 0.3 120 to 400 ± 0.4	Material (材料): 电解板	YONGU 永固	Drawing Number (图号): YG-TY-A10-003
	Weight: (重量) (Kg): 0.061		
Break sharp edges (未注锐边倒角): Ch 0.05 to 0.25 x45°	Protection: (表面处理): 毛坯	面板上固定件3	Size: (图幅): A2
	Part Name (零/部件名称):		
Position tolerances (未注位置公差): ±0.05	Angular tolerances (未注角度公差): <6° ± 10' <30° ± 20' <120° ± 30' >120° ± 1°	Part Name (零/部件名称):	Revision (版本): A1
	Drawn by (绘图): 许宏彬	Date (日期): 2020.09.18	Scale (比例): 1:1
	Check by (校对):	Date (日期):	
	Signature by (批准):	Date (日期):	

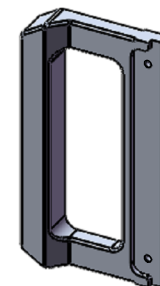
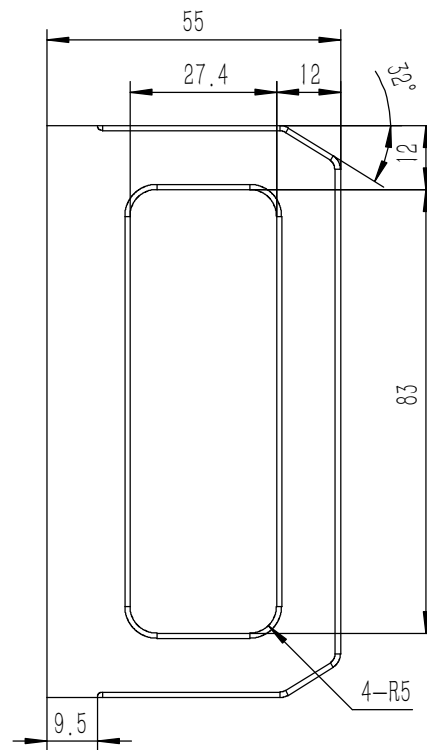
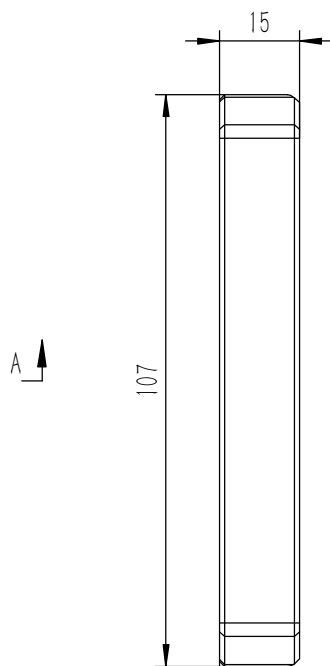
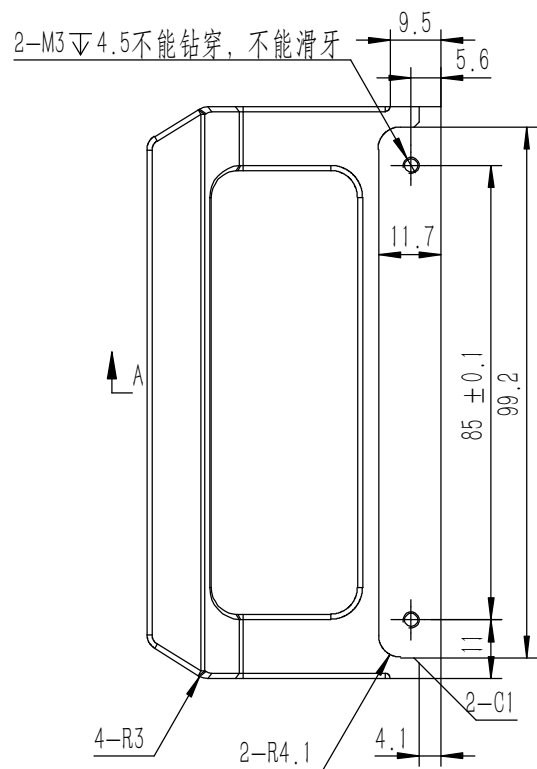
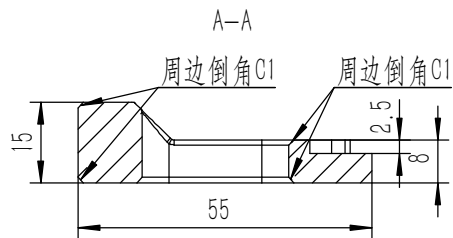

技术要求:

- 1、零件加工表面不应有划痕、擦伤等损伤零件表面的缺陷;
- 2、去除毛刺飞边, 锐角倒钝;
- 3、未标注尺寸见3D数模。

Tolerances (未注公差): 0.5 to 6 ± 0.1 6 to 30 ± 0.2 30 to 120 ± 0.3 120 to 400 ± 0.4	Material (材料):	6063-T5	
	Weight: (重量) (Kg)	0.092	
Break sharp edges (未注锐边倒角): Ch 0.05 to 0.25 x45°	Protection: (表面处理):		
	Part Name (零/部件名称):	拉手-115H	
Position tolerances (未注位置公差): ±0.05	Angular tolerances (未注角度公差): <6° ± 10' <30° ± 20' <120° ± 30' >120° ± 1°	Part Name (零/部件名称):	Drawing Number (图号):
		YONGU 永固	YG-TY-A06-002
	Drawn by (绘图): 邓展锋	Date (日期): 2020.05.18	Size (图幅): A3
	Check by (校对):	Date (日期):	Scale (比例): 1:1
	Signature by (批准):	Date (日期):	Revision (版本): A1
			Sheet (页数): 0 / 0

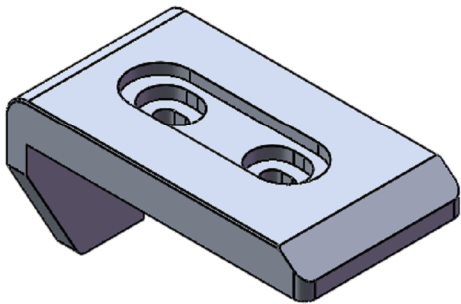
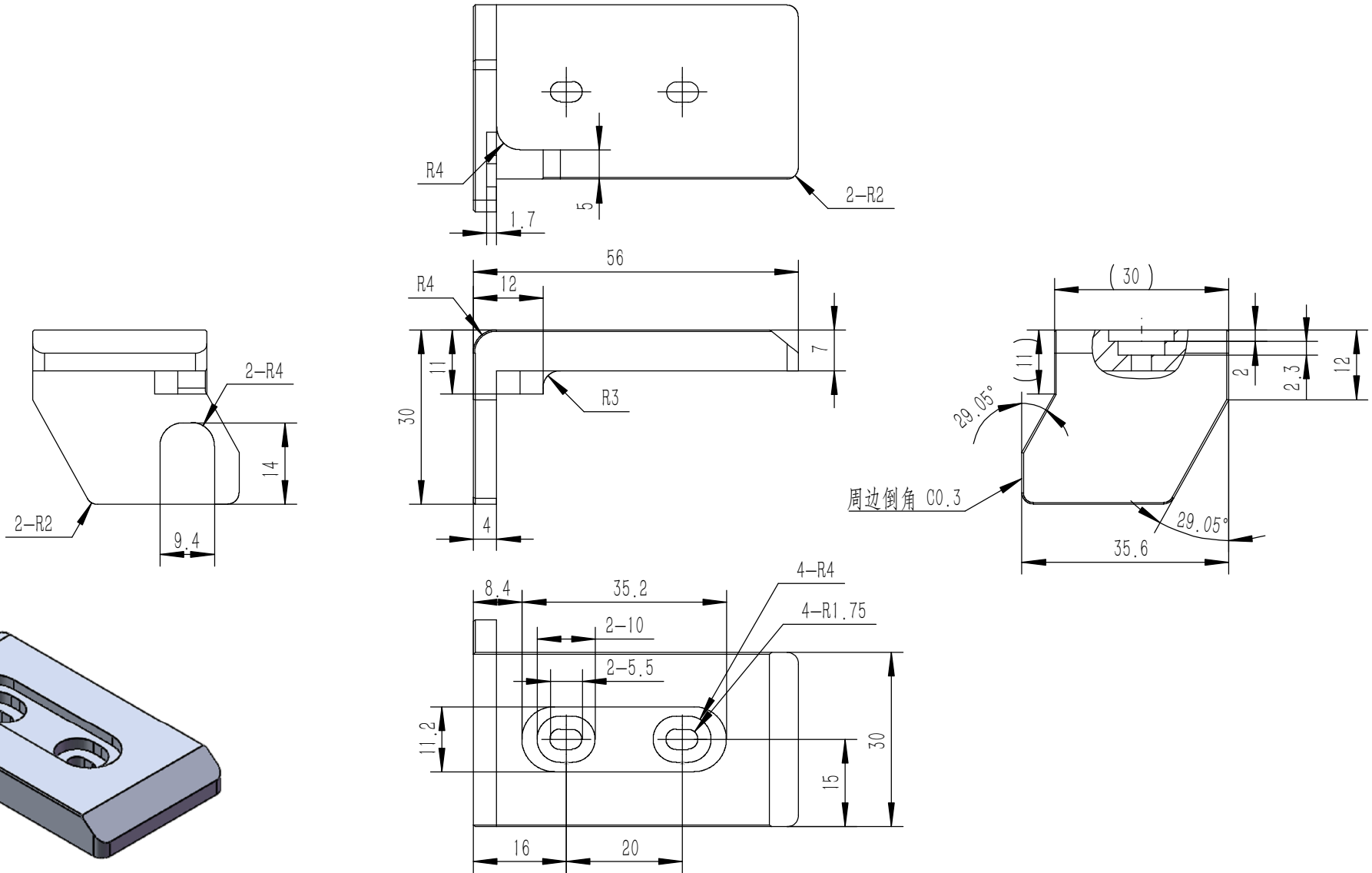

技术要求:
 1、零件加工表面不应有划痕、擦伤等损伤零件表面的缺陷;
 2、去除毛刺飞边,锐角倒钝;
 3、未标注尺寸见3D数模。

Tolerances (未注公差): 0.5 to 6 ± 0.1 6 to 30 ± 0.2 30 to 120 ± 0.3 120 to 400 ± 0.4	Material (材料): 6063-T5		YONGU 永固	
	Weight: (重量) (Kg) 0.035			
Break sharp edges (未注锐边倒角): Ch 0.05 to 0.25 x45° Position tolerances (未注位置公差): ±0.05	Protection: (表面处理):		Part Name (零/部件名称):	
	Angular tolerances (未注角度公差): <6° ± 10' <30° ± 20' <120° ± 30' >120° ± 1°		B包角2	
Drawing Number (图号):		YG-TY-B05-002		
Scale (比例): 1:1		Sheet (页数):		
Revision (版本): A1		1 / 1		

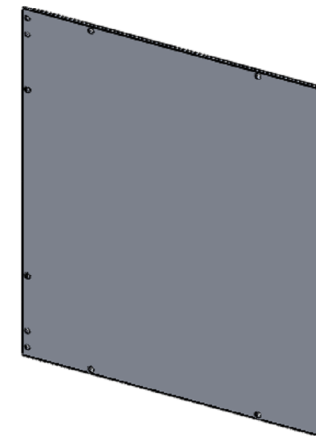
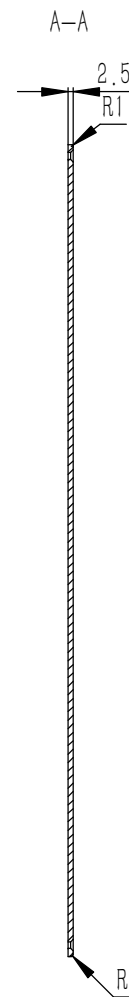
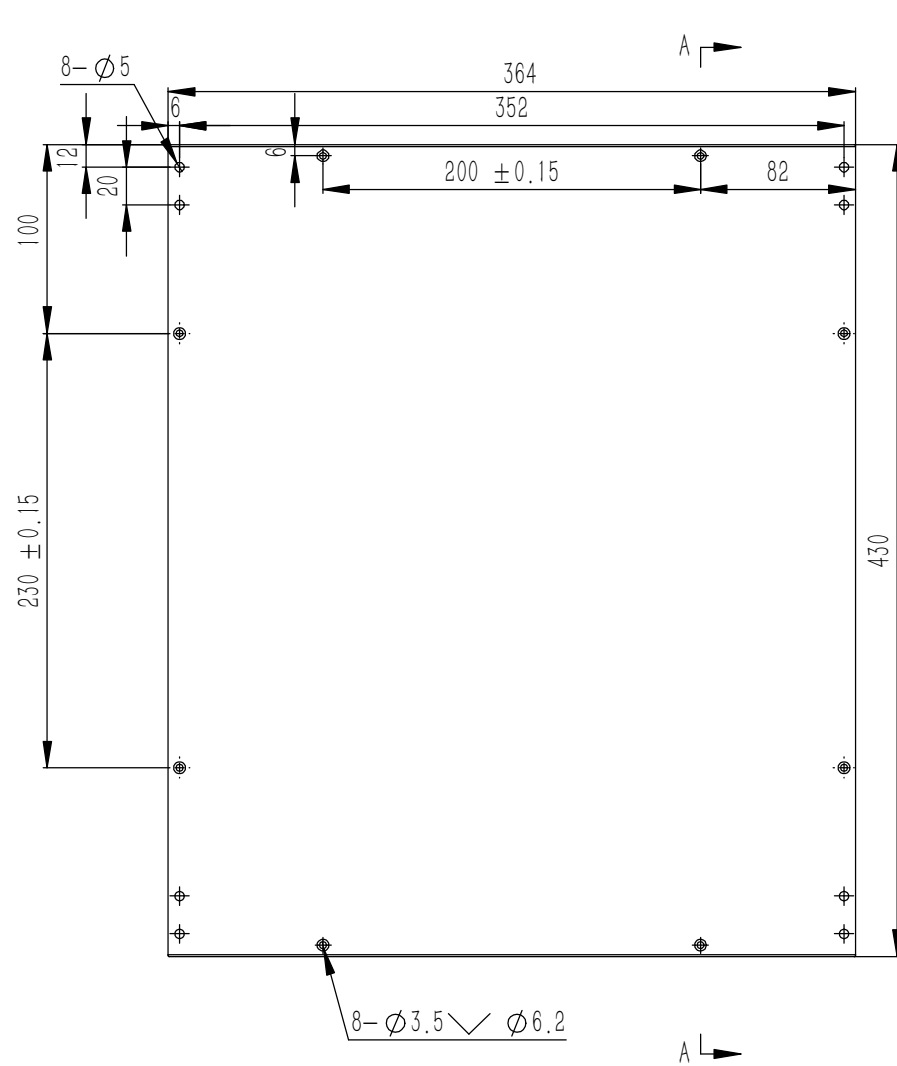

技术要求:

- 1、零件加工表面不应有划痕、擦伤等损伤零件表面的缺陷;
- 2、去除毛刺飞边,锐角倒钝;
- 3、未标注尺寸见3D数模。

Break sharp edges (未注锐边倒角): Ch 0.05 to 0.25 x45°	Angular tolerances (未注角度公差): <6° ± 10' <30° ± 20' <120° ± 30' >120° ± 1°
Position tolerances (未注位置公差): ±0.05	

Tolerances (未注公差): 0.5 to 6 ± 0.1 6 to 30 ± 0.2 30 to 120 ± 0.3 120 to 400 ± 0.4	Material (材料):	5052-H32		YONGU 永固
	Weight: (重量) (Kg):	1.046		
	Protection: (表面处理):			
	Part Name (零/部件名称):	上下盖板		Drawing Number (图号): YG-TY-B01-011
	Drawn by (绘图): 邓展锋	Date (日期): 2020.05.19	Size (图幅): A0	Sheet (页数): 1 / 1
	Check by (校对):	Date (日期):	Scale (比例): 1:1	
	Signature by (批准):	Date (日期):	Revision (版本): A1	

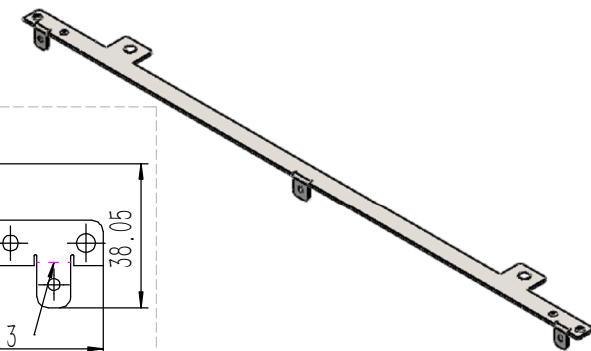
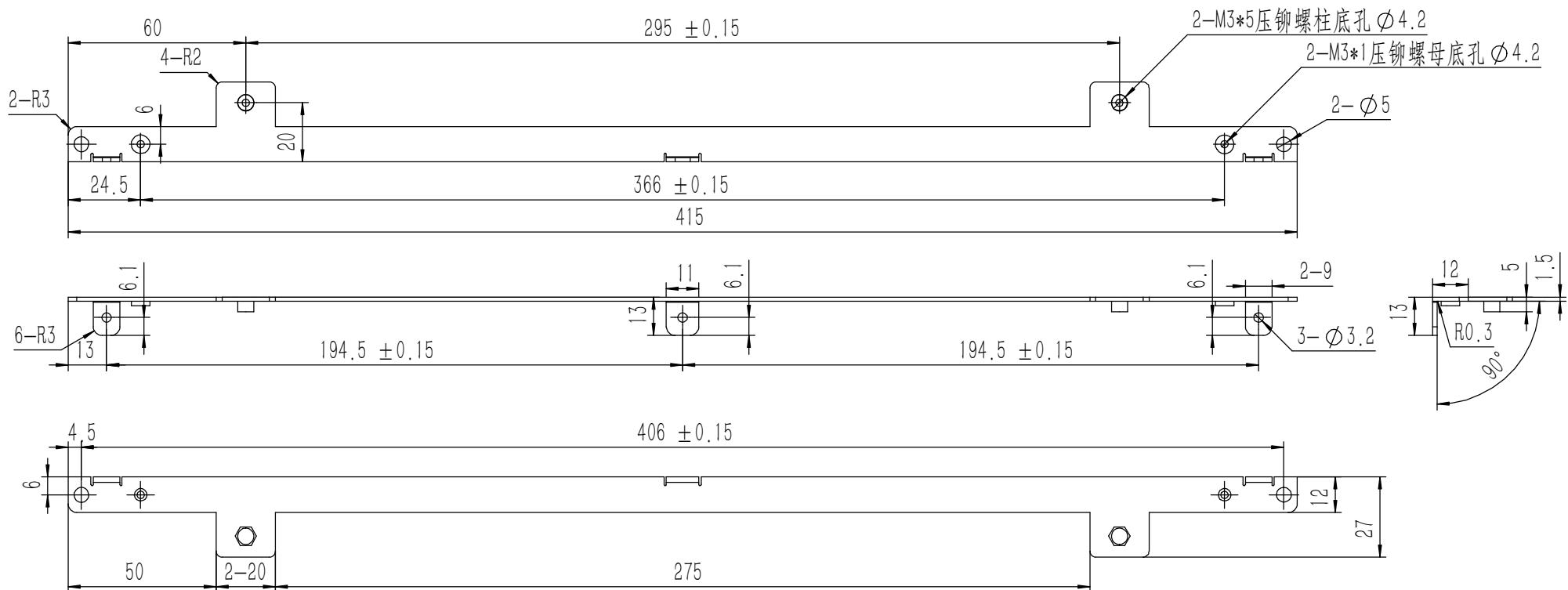

钣金展开及折弯方向参考图 (视图比例1:1)

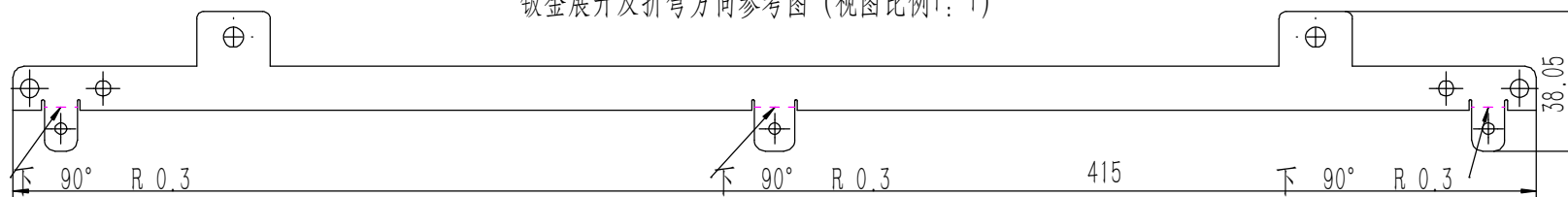

业务代码:

技术要求:

- 1、零件加工表面不应有划痕、擦伤等损伤零件表面的缺陷;
- 2、去除毛刺飞边, 锐角倒钝;
- 3、未标注尺寸见3D数模。

Tolerances (未注公差): 0.5 to 6 ± 0.1 6 to 30 ± 0.2 30 to 120 ± 0.3 120 to 400 ± 0.4	Material (材料): (装配图)	YONGU 永固	Drawing Number (图号):	
	Weight: (重量) (Kg): 0.069		YG-TY-A11-003	
Break sharp edges (未注锐边倒角): Ch 0.05 to 0.25 x45°	Protection: (表面处理): 毛坯	Part Name (零/部件名称): 面板下固定件3	Size: (图幅): A2	Sheet (页数): 1 / 1
	Angular tolerances (未注角度公差): <6° ± 10' <30° ± 20' <120° ± 30' >120° ± 1°		Part Name (零/部件名称):	
Position tolerances (未注位置公差): ±0.05	Part Name (零/部件名称):	Signature by (批准):	Revision (版本): A1	

2-M3 4.5不能钻穿，不能滑牙

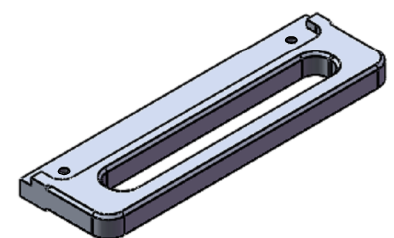
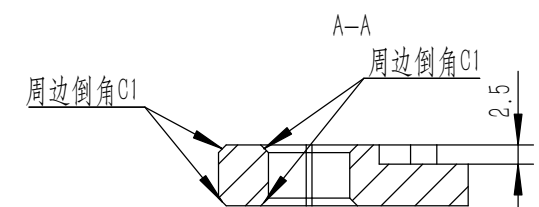
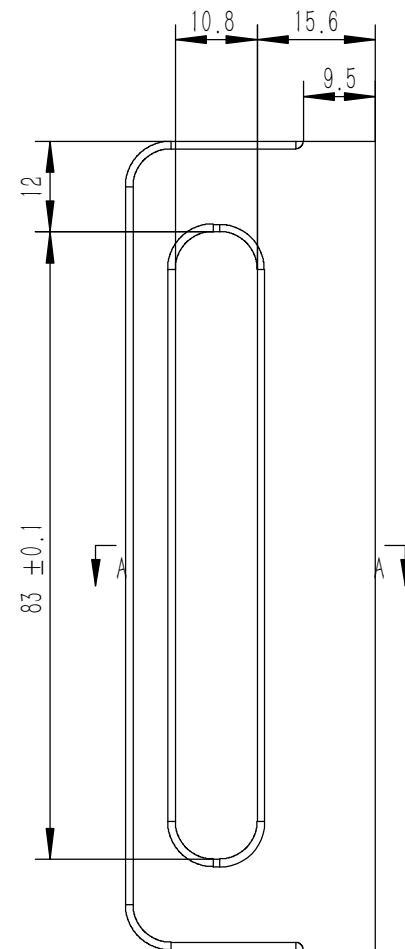
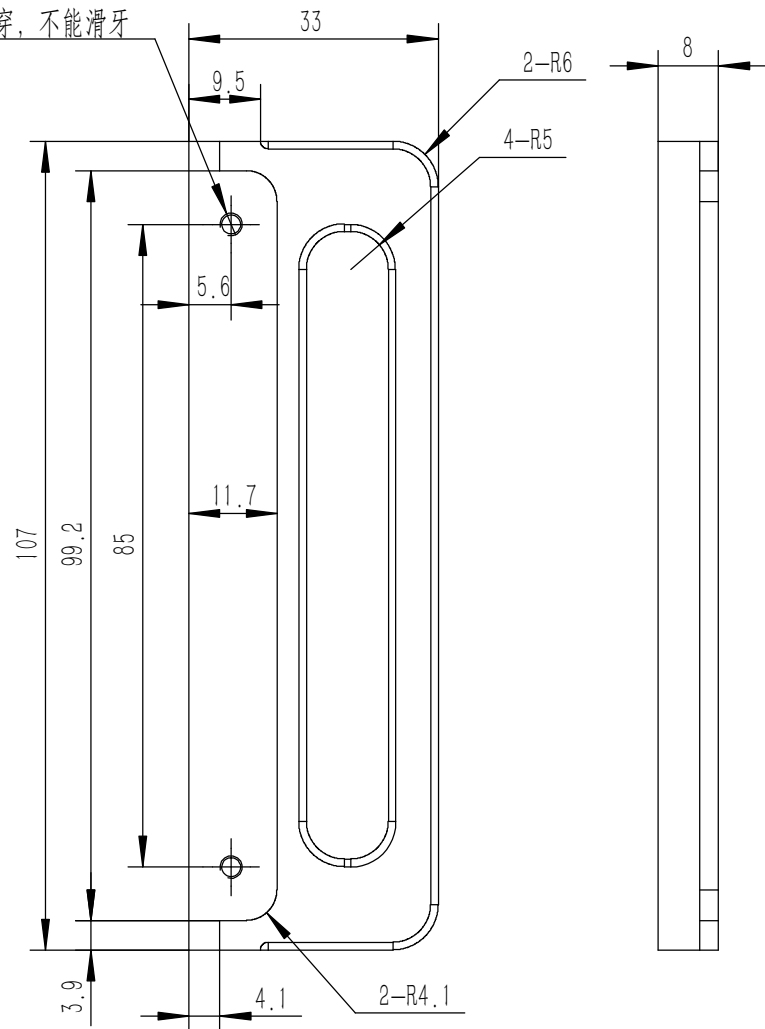

- 技术要求:
- 1、零件加工表面不应有划痕、擦伤等损伤零件表面的缺陷;
 - 2、去除毛刺飞边，锐角倒钝;
 - 3、未标注尺寸见3D数模。

Tolerances (未注公差): 0.5 to 6 ± 0.1 6 to 30 ± 0.2 30 to 120 ± 0.3 120 to 400 ± 0.4	Material (材料):	5052-H32		YONGU 永固	
	Weight: (重量) (Kg)	0.048			
	Protection: (表面处理):				
	Part Name (零/部件名称):	后防护条-115H		Drawing Number (图号):	YG-TY-A07-002
Break sharp edges (未注锐边倒角): Ch 0.05 to 0.25 x45°	Angular tolerances (未注角度公差): <6° ± 10' <30° ± 20' <120° ± 30' >120° ± 1°	Drawn by (绘图): 邓展锋	Date (日期): 2020.05.18	Size: (图幅): A4	
Position tolerances (未注位置公差): ±0.05		Check by (校对):	Date (日期):	Scale (比例): 1:1	Sheet (页数):
		Signature by (批准):	Date (日期):	Revision (版本): A1	1 / 1

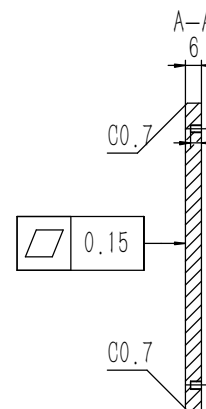
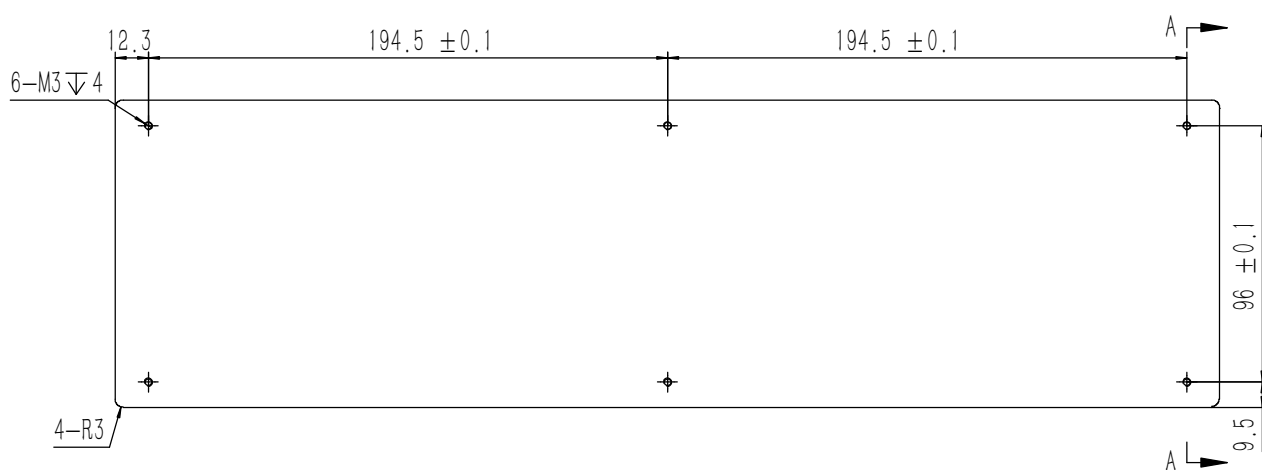
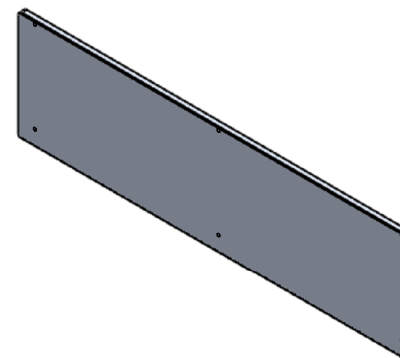
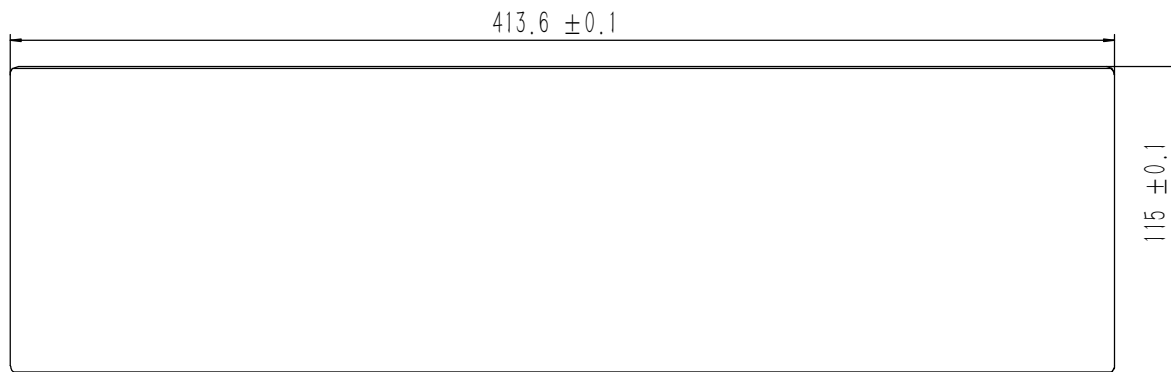

- 技术要求:
- 1、零件加工表面不应有划痕、擦伤等损伤零件表面的缺陷;
 - 2、去除毛刺飞边, 锐角倒钝;
 - 3、未标注尺寸见3D数模。

Tolerances (未注公差): 0.5 to 6 ± 0.1 6 to 30 ± 0.2 30 to 120 ± 0.3 120 to 400 ± 0.4	Material (材料):	5052-H32	
	Weight: (重量) (Kg):	0.764	
Break sharp edges (未注锐边倒角): Ch 0.05 to 0.25 x45°	Protection: (表面处理):		
	Position tolerances (未注位置公差): ± 0.05	Part Name (零/部件名称): 前后面板-115H	
Angular tolerances (未注角度公差): <6° ± 10' <30° ± 20' <120° ± 30' >120° ± 1°	Drawing Number (图号):		YG-TY-A12-010
	Drawn by (绘图): 莫永康	Date (日期): 2020.05.18	Size: (图幅): A1
	Check by (校对):	Date (日期):	Scale (比例): 1:1
	Signature by (批准):	Date (日期):	Revision (版本): A1
			Sheet (页数): 1 / 1

YONGU 永固

钣金展开及折弯方向参考图 (视图比例1:1)

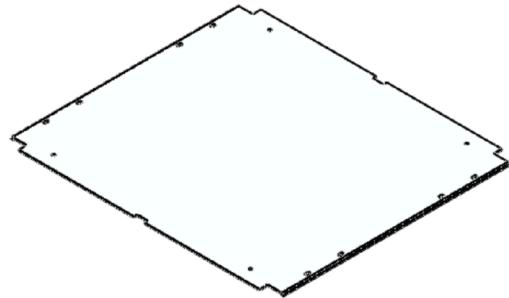
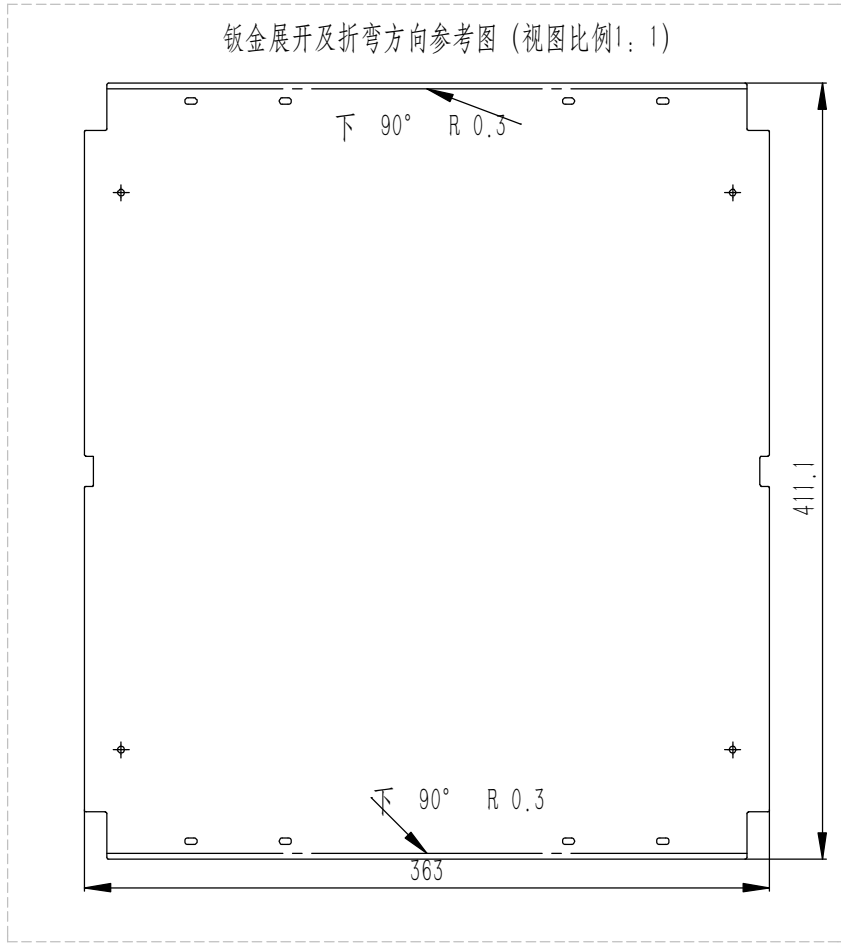

技术要求:

- 1、零件加工表面不应有划痕、擦伤等损伤零件表面的缺陷;
- 2、去除毛刺飞边, 锐角倒钝;
- 3、未标注尺寸见3D数模。

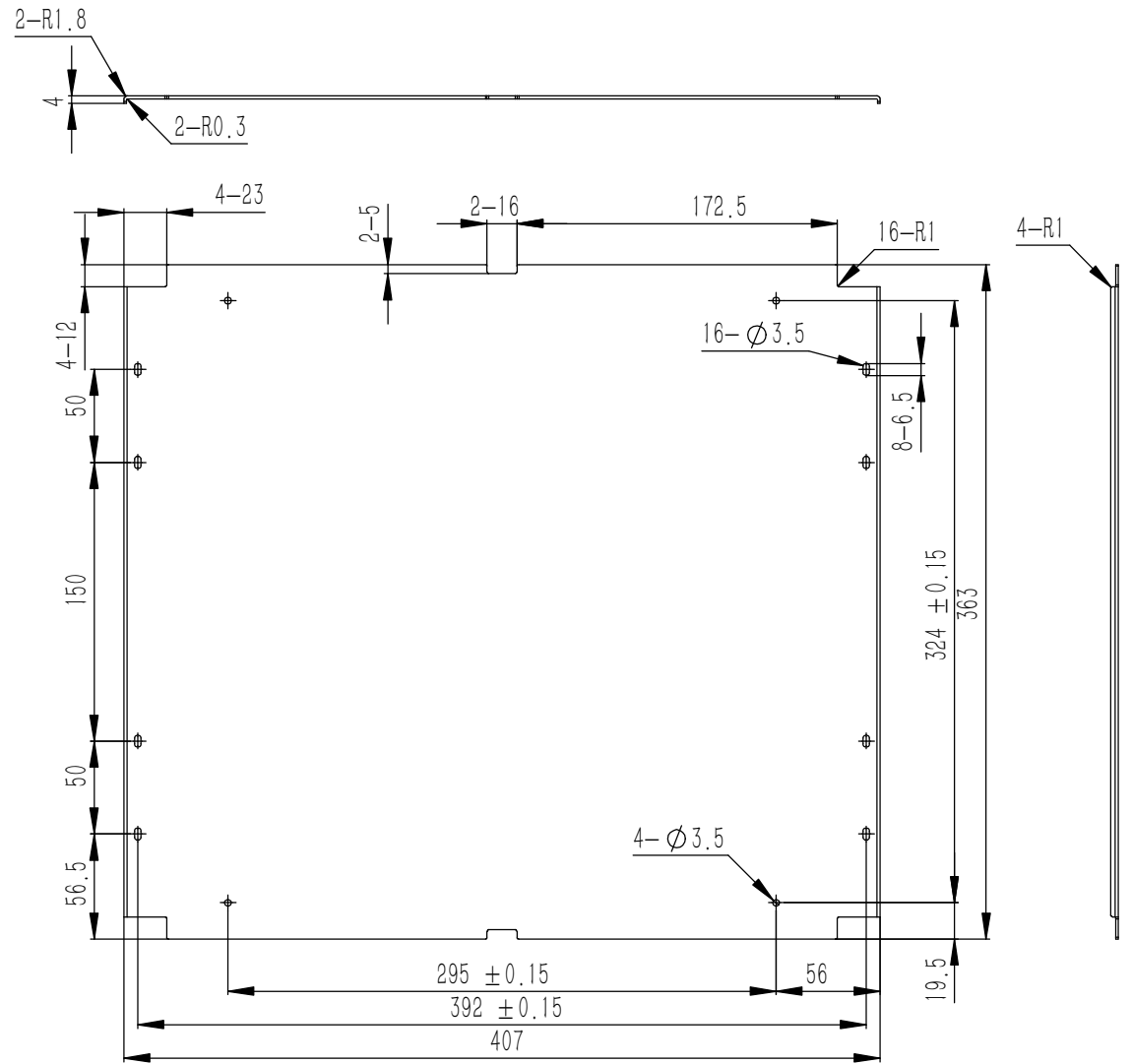

业务代码:

Tolerances (未注公差): 0.5 to 6 ± 0.1 6 to 30 ± 0.2 30 to 120 ± 0.3 120 to 400 ± 0.4	Material (材料):	5052-H32		YONGU 永固
	Weight: (重量) (Kg):	0.594		
Break sharp edges (未注锐边倒角): Ch 0.05 to 0.25 x45°	Protection: (表面处理):			
	Part Name (零/部件名称):	A垫板		Drawing Number (图号): YG-TY-A13-011
Position tolerances (未注位置公差): ± 0.05	Angular tolerances (未注角度公差): <6° ± 10' <30° ± 20' <120° ± 30' >120° ± 1°	Drawn by (绘图): 许宏彬	Date (日期): 2020.09.17	Size (图幅): A0
		Check by (校对):	Date (日期):	Scale (比例): 1:1
		Signature by (批准):	Date (日期):	Revision (版本): A1
				Sheet (页数): 1 / 1