

**技术要求:**

- 1、必须按照设计、工艺要求及本规定和有关标准进行装配;
- 2、所有零部件(包括外购、外协件)必须具有检验合格证方能进行装配;
- 3、零件在装配前必须清理和清洗干净,不得有毛刺、飞边、氧化皮、锈蚀、切屑、砂粒、灰尘和油污等,并应符合相应清洁度要求;
- 4、装配过程中零件不得磕碰、划伤和锈蚀;
- 5、油漆未干的零件不得进行装配;
- 6、相对运动的零件,装配时接触面间应加润滑油脂;
- 7、各零、部件装配后相对位置应准确。

业务代码:

6	GB-T-70.1-2000-S-NL-M3X8	不锈钢内六角杯头螺丝M3X8	SUS 304	8	0.001	
5	GB-T-819.1-2000-C-NI-M3X6	碳钢镀镍十字沉头螺丝M3X6	普通碳钢	4	0.0004	
4	YG-L04B-0000-003	垫板	5052-H32	1	0.042	
3	YG-L04B02-0000-002	L04B灰白塑料端盖	ABS	2	0.042	
2	YG-L04B-0000-006	L04B点胶密封圈	复合发泡胶	2	0.006	
1	YG-L04A-0000-001	壳体	6063-T5	1	0.110	
序号 (Item)	图号 (Drawing Number)	名称 (Part Name)	材料 (Material)	数量 (QTY)	单重 (Weight)	备注 (Note)

Tolerances (未注公差):		Material (材料): (装配图)		<b>YONGU</b>	
0.5 to 6 ± 0.1	6 to 30 ± 0.2	Weight: (重量) (Kg): 0.257			
30 to 120 ± 0.3	120 to 400 ± 0.4	Protection: (表面处理):		Drawing Number (图号):	
Angular tolerances (未注角度公差):		Part Name (零/部件名称):		YG-L04B-0000-000	
<6° ± 10'		YG-L04B防水壳体		Size: (图幅): A2	
<30° ± 20'		Drawn by (绘图): 许宏彬		Date (日期): 2020.10.30	
<120° ± 30'		Check by (校对):		Date (日期):	
>120° ± 1°		Signature by (批准):		Date (日期):	
Break sharp edges (未注锐边倒角): Ch 0.05 to 0.25 x45°		Position tolerances (未注位置公差): ±0.05		Scale (比例): 1:1	
				Revision (版本): A1	
				Sheet (页数): 1 / 1	

3.2

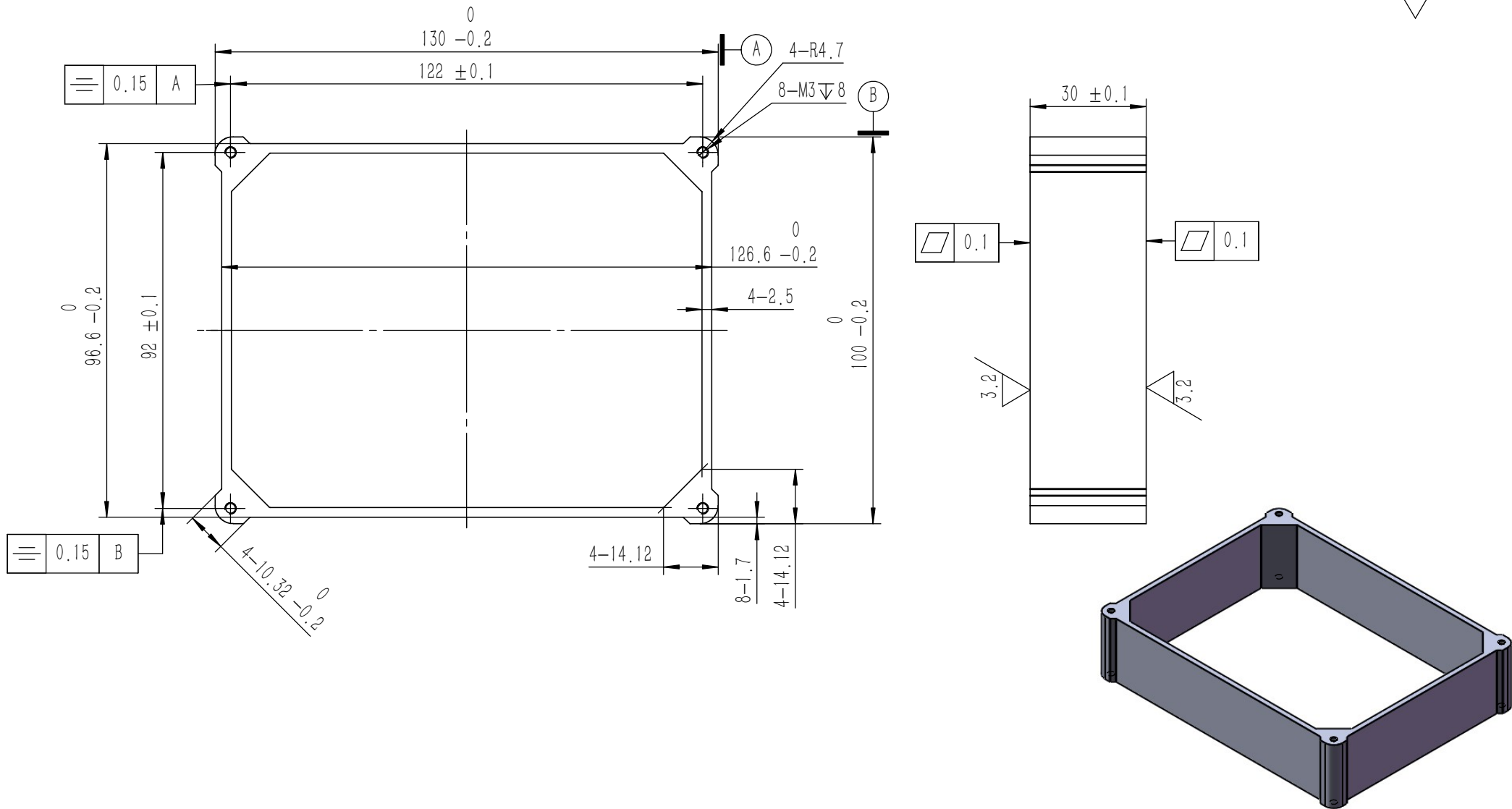

技术要求:

- 1、零件加工表面不应有划痕、擦伤等损伤零件表面的缺陷;
- 2、去除毛刺飞边,锐角倒钝;
- 3、未标注尺寸见3D数模。

业务代码:

Break sharp edges (未注锐边倒角): Ch 0.05 to 0.25 x45°	Angular tolerances (未注角度公差): <6° ± 10' <30° ± 20' <120° ± 30' >120° ± 1°	Tolerances (未注公差): 0.5 to 6 ± 0.1 6 to 30 ± 0.2 30 to 120 ± 0.3 120 to 400 ± 0.4	Material (材料): 6063-T5 Weight: (重量) (Kg) 0.110	<b>YONGU</b> 永固	
		Position tolerances (未注位置公差): ±0.05	Protection: (表面处理): Part Name (零/部件名称): 壳体		Drawing Number (图号): YG-L04A-0000-001
		Drawn by (绘图): 许宏彬 Check by (校对): Signature by (批准):	Date (日期): 2021.05.26 Date (日期): Date (日期):	Size: (图幅): A3 Scale (比例): 1:1 Revision (版本): A1	Sheet (页数): 1 / 1

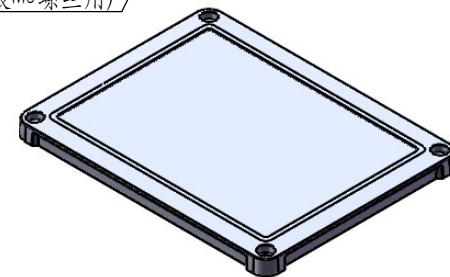
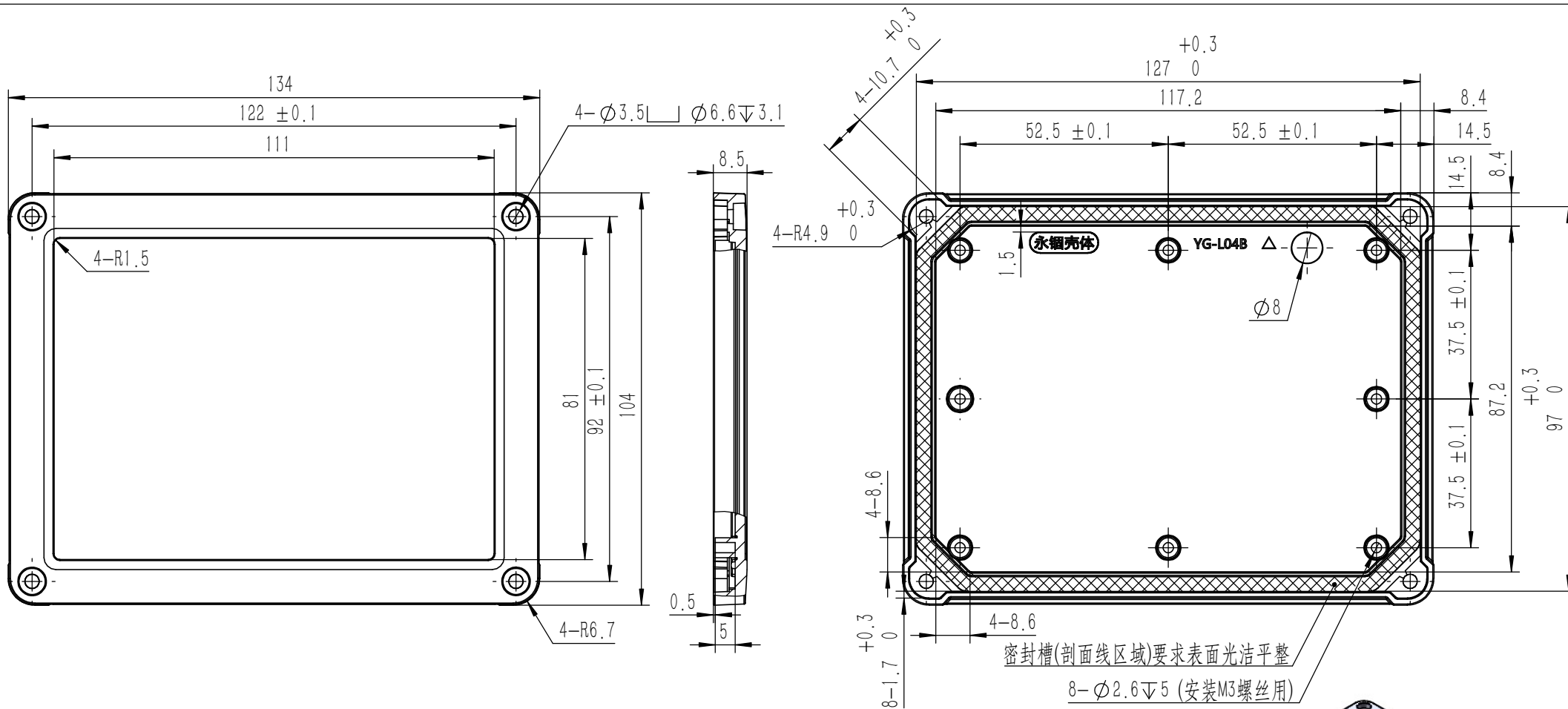

技术要求:

- 1、零件表面不允许有收缩、凹陷、熔接痕、水纹、顶白及飞边等缺陷
- 2、未标注尺寸见3D数模。

业务代码:

Tolerances (未注公差): 0.5 to 6 ± 0.1 6 to 30 ± 0.2 30 to 120 ± 0.3 120 to 400 ± 0.4	Material (材料):	ABS	<b>YONGFU</b> 永福
	Weight: (重量) (Kg)	0.042	
Break sharp edges (未注锐边倒角): Ch 0.05 to 0.25 x45°	Protection: (表面处理):		Drawing Number (图号): YG-L04B02-0000-002
	Angular tolerances (未注角度公差): <6° ± 10' <30° ± 20' <120° ± 30' >120° ± 1°	Part Name (零/部件名称): L04B灰白塑料端盖	
Position tolerances (未注位置公差): ±0.05	Drawn by (绘图): 许宏彬	Date (日期): 2021.05.26	Sheet (页数): 1 / 1
	Check by (校对):	Date (日期):	Scale (比例): 1:1
	Signature by (批准):	Date (日期):	Revision (版本): A1

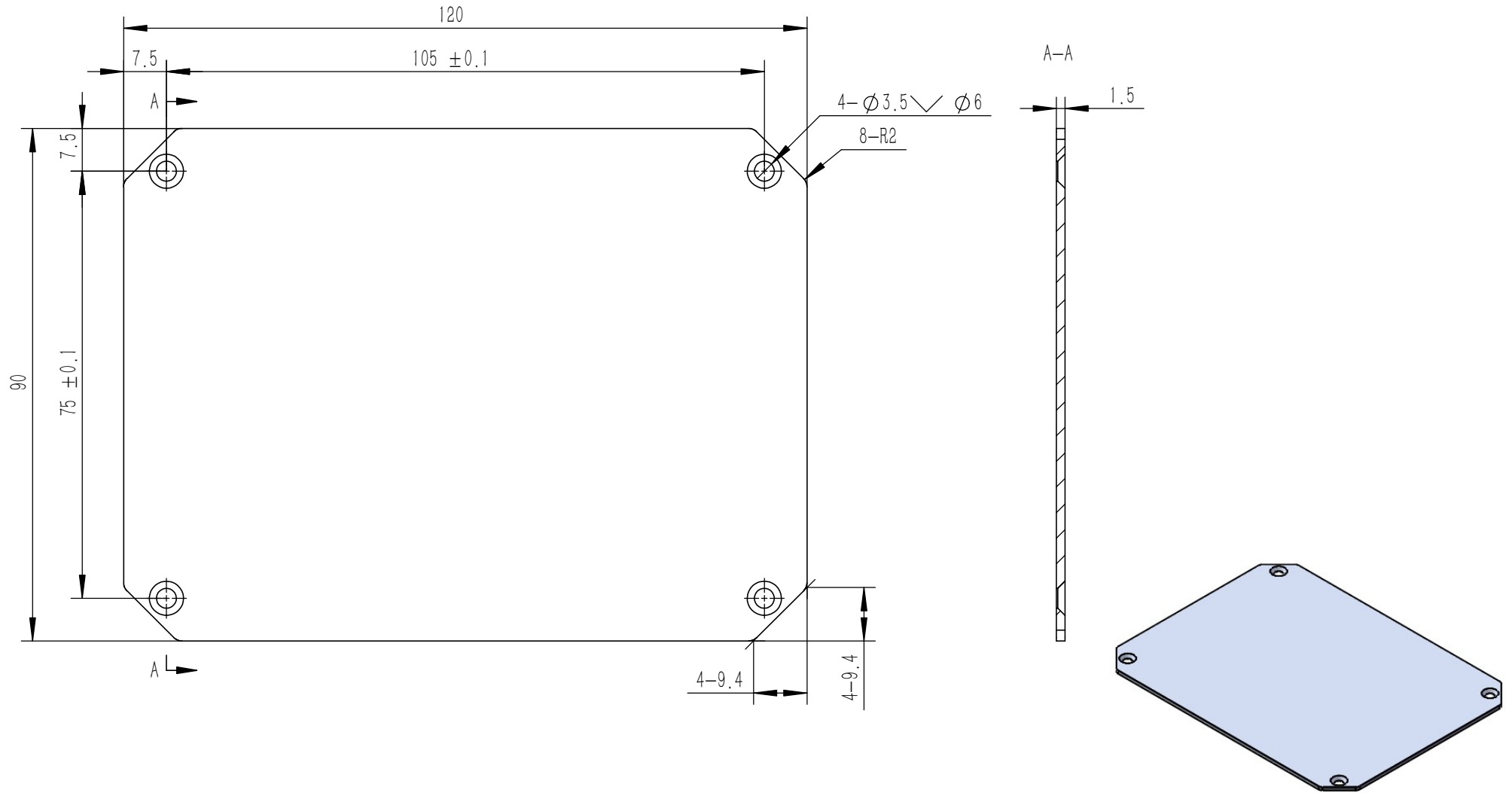

技术要求:

- 1、零件加工表面不应有划痕、擦伤等损伤零件表面的缺陷;
- 2、去除毛刺飞边,锐角倒钝;
- 3、未标注尺寸见3D数模。

业务代码:

Tolerances (未注公差): 0,5 to 6 ± 0,1 6 to 30 ± 0,2 30 to 120 ± 0,3 120 to 400 ± 0,4	Material (材料):	5052-H32		<b>YONGU</b> 永固
	Weight: (重量) (Kg)	0.042		
Break sharp edges (未注锐边倒角): Ch 0.05 to 0.25 x45°	Protection: (表面处理):			
	Position tolerances (未注位置公差): ±0.05	Part Name (零/部件名称):	垫板	
Angular tolerances (未注角度公差): <6° ± 10' <30° ± 20' <120° ± 30' >120° ± 1°	Part Name (零/部件名称):	垫板		Drawing Number (图号):
	Drawn by (绘图):	许宏彬	Date (日期):	2021.05.26
	Check by (校对):		Date (日期):	
	Signature by (批准):		Date (日期):	
		Scale (比例):	1:1	
		Revision (版本):	A1	
		Sheet (页数):	1 / 1	