

序号	图号	名称	材料	数量	单重	备注
6	YG-C08B-0000-002	后面板	6063-T5	1	0.376	
5	YG-C08B-0000-004	侧板	6063-T5	2	0.289	
4	GB-T-819.1-2000-C-NI-M3X6	碳钢镀锌十字沉头螺丝M3X6	普通碳钢	36	0.0004	
3	YG-TY-JM-001	角码30X30X1.5	普通碳钢	8	0.005	
2	YG-C08B-0000-001	前面板	6063-T5	1	0.638	
1	YG-C08B-0000-003	盖板	5052-H32	2	0.521	

技术要求:

- 1、必须按照设计、工艺要求及本规定和有关标准进行装配;
- 2、所有零部件(包括外购、外协件)必须具有检验合格证方能进行装配;
- 3、零件在装配前必须清理和清洗干净,不得有毛刺、飞边、氧化皮、锈蚀、切屑、砂粒、灰尘和油污等,并应符合相应清洁度要求;
- 4、装配过程中零件不得磕碰、划伤和锈蚀;
- 5、油漆未干的零件不得进行装配;
- 6、相对运动的零件,装配时接触面间应加润滑油脂;
- 7、各零、部件装配后相对位置应准确。

Break sharp edges (未注锐边倒角): Ch 0.05 to 0.25 x45°	Angular tolerances (未注角度公差): <6° ± 10' <30° ± 20' <120° ± 30' >120° ± 1°
Position tolerances (未注位置公差): ± 0.05	

Tolerances (未注公差): 0.5 to 6 ± 0.1 6 to 30 ± 0.2 30 to 120 ± 0.3 120 to 400 ± 0.4	Material (材料): (装配图)
	Weight: (重量) (Kg): 2.688
	Protection: (表面处理):
	Part Name (零/部件名称):

**YONGU** 永固

C08B机箱		Drawing Number (图号): YG-C08B-0000-000	
Drawn by (绘图): 邓展锋	Date (日期): 2020.05.25	Size (图幅): A0	Sheet (页数): 1 / 1
Check by (校对):	Date (日期):	Scale (比例): 1:1.2	Revision (版本): A1
Signature by (批准):	Date (日期):		

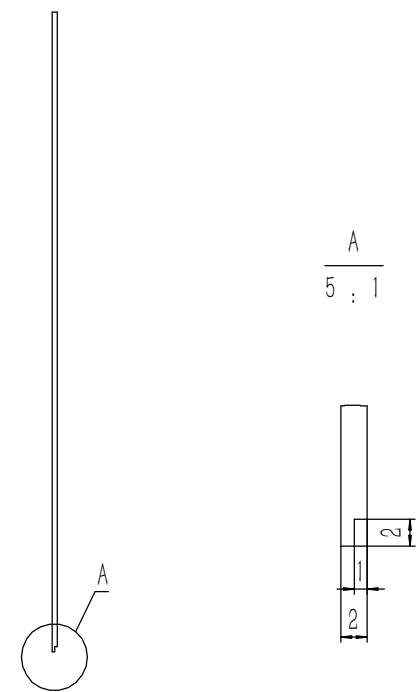
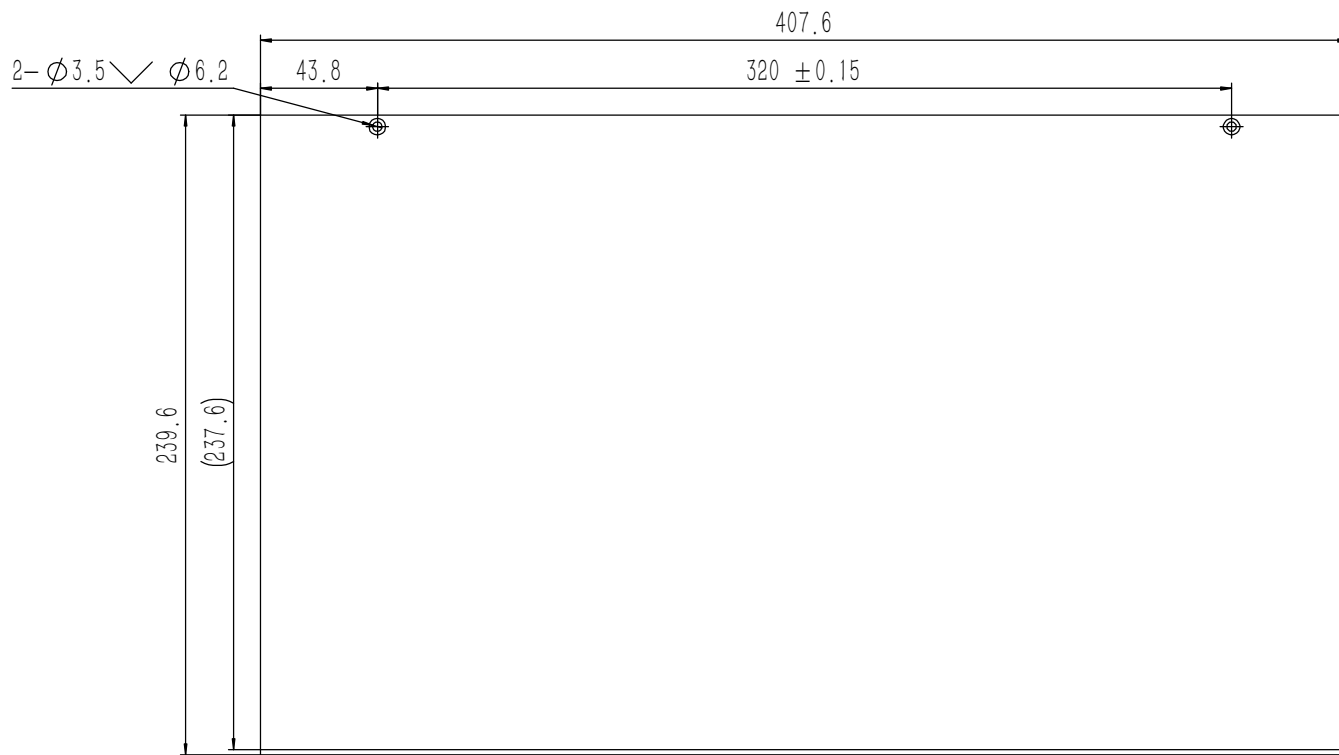

技术要求:

- 1、零件加工表面不应有划痕、擦伤等损伤零件表面的缺陷;
- 2、去除毛刺飞边,锐角倒钝;
- 3、未标注尺寸见3D数模。

Tolerances (未注公差): 0.5 to 6 ± 0.1 6 to 30 ± 0.2 30 to 120 ± 0.3 120 to 400 ± 0.4	Material (材料):	5052-H32	
	Weight: (重量) (Kg):	0.521	
Break sharp edges (未注锐边倒角): Ch 0.05 to 0.25 x45°	Protection: (表面处理):		
	Part Name (零/部件名称):	盖板	
Position tolerances (未注位置公差): ± 0.05	Drawing Number (图号):	YG-C08B-0000-003	
	Angular tolerances (未注角度公差): <6° ± 10' <30° ± 20' <120° ± 30' >120° ± 1°	Drawn by (绘图):	邓展锋
	Date (日期):	2020.05.25	
	Check by (校对):	Date (日期):	
	Signature by (批准):	Date (日期):	
	Size: (图幅):	A1	
	Scale (比例):	1:1	
	Revision (版本):	A1	
	Sheet (页数):	1 / 1	



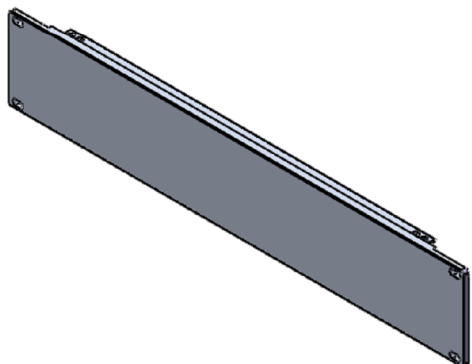
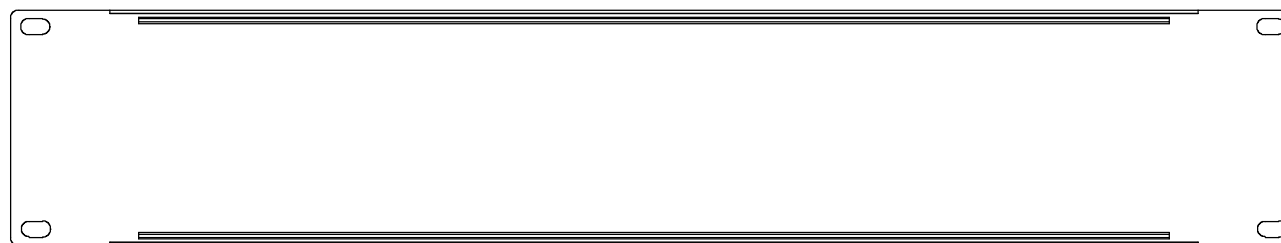
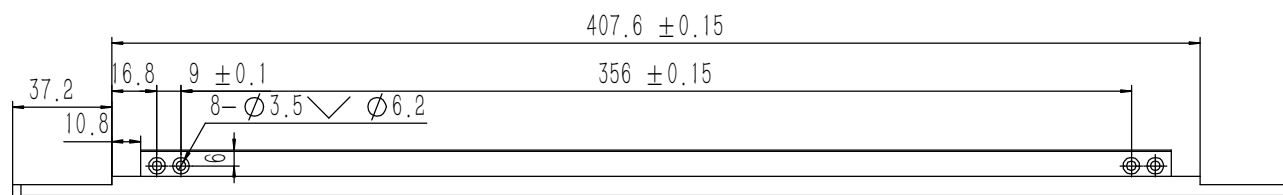
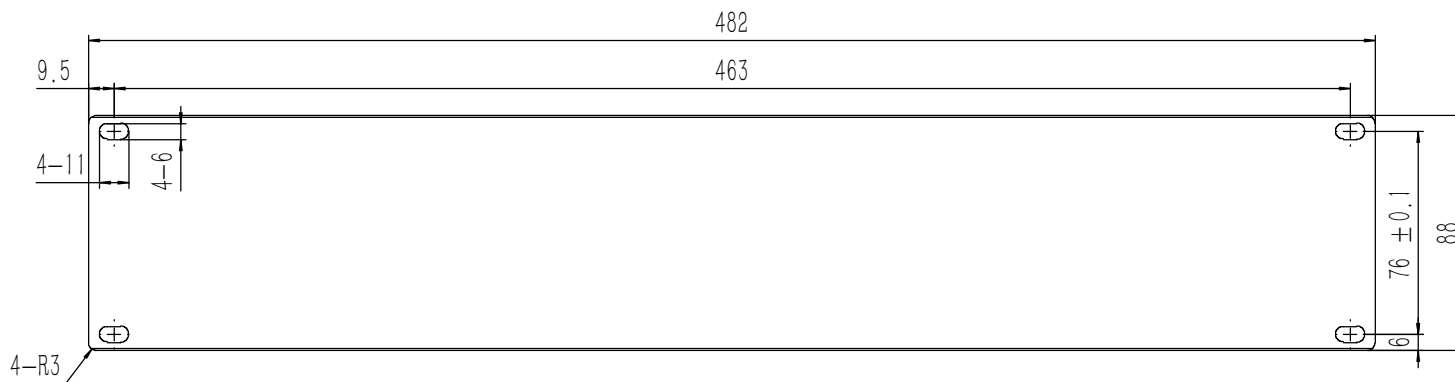
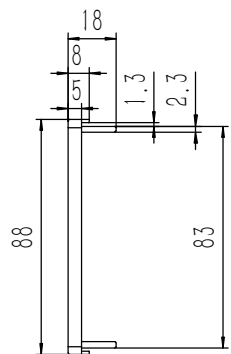

技术要求:

- 1、零件加工表面不应有划痕、擦伤等损伤零件表面的缺陷;
- 2、去除毛刺飞边, 锐角倒钝;
- 3、未标注尺寸见3D数模。

Tolerances (未注公差): 0.5 to 6 ± 0.1 6 to 30 ± 0.2 30 to 120 ± 0.3 120 to 400 ± 0.4	Material (材料):	6063-T5		<b>YONGU</b> 永固
	Weight: (重量) (Kg):	0.638		
Break sharp edges (未注锐边倒角): Ch 0.05 to 0.25 x45°	Protection: (表面处理):			
	Position tolerances (未注位置公差): ± 0.05	Part Name (零/部件名称):	前面板	
Angular tolerances (未注角度公差): <6° ± 10' <30° ± 20' <120° ± 30' >120° ± 1°	Drawing Number (图号):	YG-C08B-0000-001		
	Drawn by (绘图):	邓展锋	Date (日期):	2020.05.25
	Check by (校对):		Date (日期):	
	Signature by (批准):		Date (日期):	
	Size: (图幅):	A1		Sheet (页数):
	Scale (比例):	1:1		1 / 1
	Revision (版本):	A1		

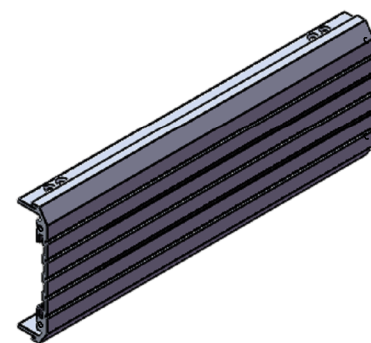
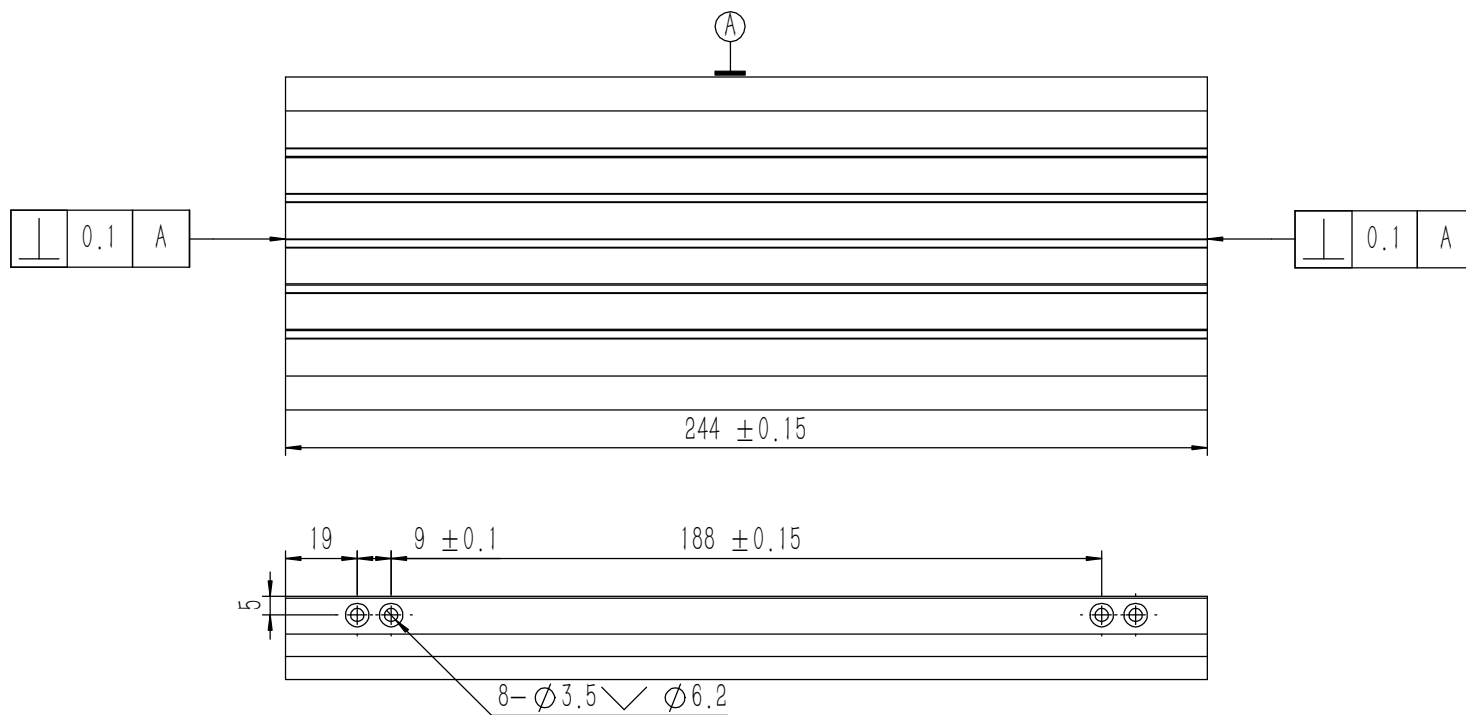
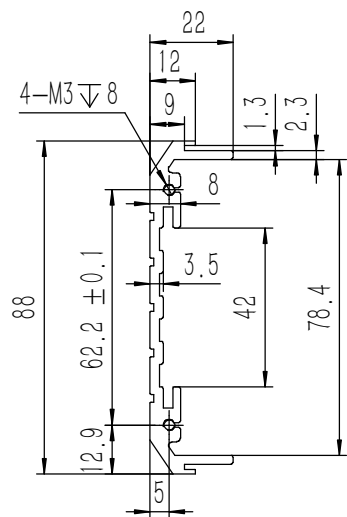

- 技术要求:
- 1、零件加工表面不应有划痕、擦伤等损伤零件表面的缺陷;
  - 2、去除毛刺飞边,锐角倒钝;
  - 3、未标注尺寸见3D数模。

Tolerances (未注公差): 0.5 to 6 ± 0.1 6 to 30 ± 0.2 30 to 120 ± 0.3 120 to 400 ± 0.4	Material (材料):	6063-T5	
	Weight: (重量) (Kg):	0.289	
	Protection: (表面处理):		
	Part Name (零/部件名称):	侧板	
Break sharp edges (未注锐边倒角): Ch 0.05 to 0.25 x45°	Angular tolerances (未注角度公差): <6° ± 10' <30° ± 20' <120° ± 30' >120° ± 1°	Drawing Number (图号): YG-C08B-0000-004	Size: (图幅): A2
Position tolerances (未注位置公差): ±0.05	Drawn by (绘图): 邓展锋	Date (日期): 2020.05.25	Scale (比例): 1:1
	Check by (校对):	Date (日期):	Revision (版本): A1
	Signature by (批准):	Date (日期):	Sheet (页数): 1 / 1

**YONGU** 永固

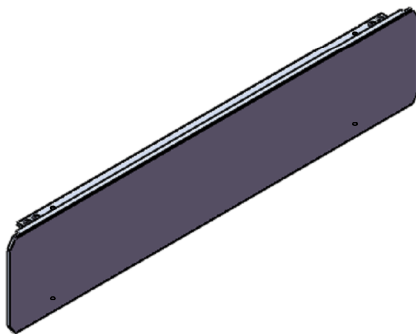
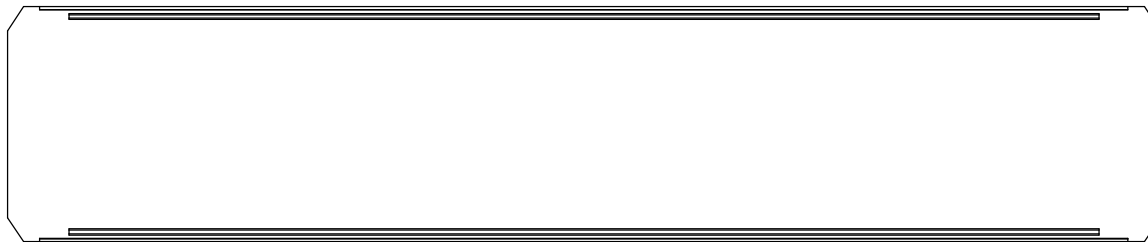
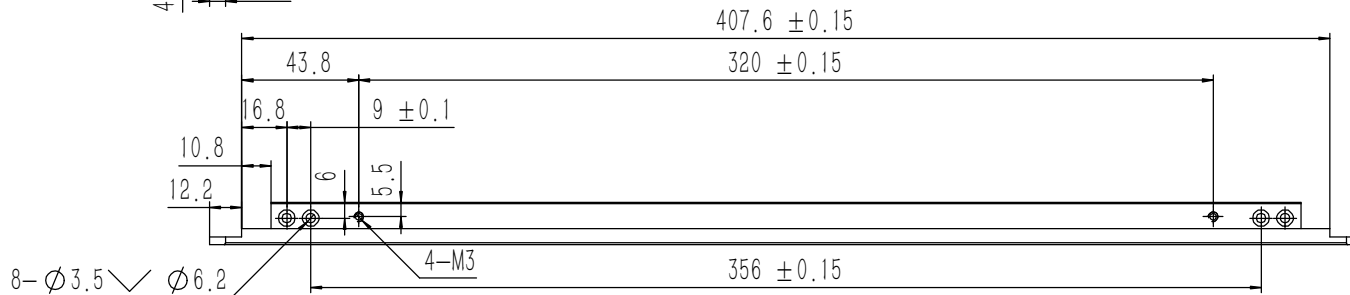
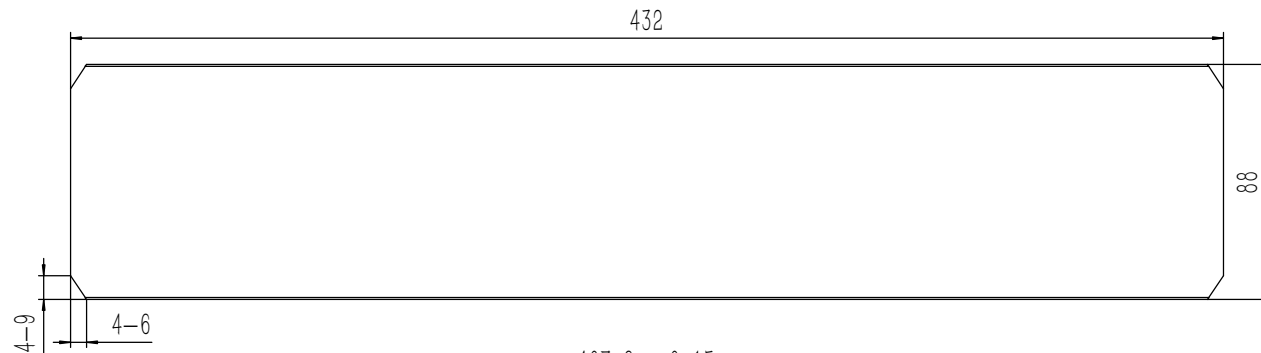
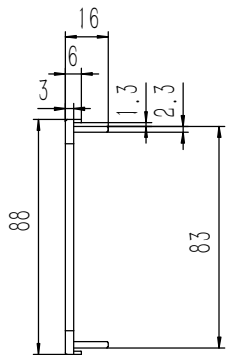

技术要求:

- 1、零件加工表面不应有划痕、擦伤等损伤零件表面的缺陷;
- 2、去除毛刺飞边,锐角倒钝;
- 3、未标注尺寸见3D数模。

Tolerances (未注公差):	
0.5 to 6	± 0.1
6 to 30	± 0.2
30 to 120	± 0.3
120 to 400	± 0.4

Break sharp edges (未注锐边倒角): Ch 0.05 to 0.25 x45°	
Position tolerances (未注位置公差): ± 0.05	

Angular tolerances (未注角度公差):	
<6°	± 10'
<30°	± 20'
<120°	± 30'
>120°	± 1°

Material (材料):	6063-T5
Weight: (重量) (Kg):	0.376
Protection: (表面处理):	
Part Name (零/部件名称):	后面板

		Drawing Number (图号):	
		YG-C08B-0000-002	

Drawn by (绘图): 邓展锋	Date (日期): 2020.05.25	Size: (图幅): A1	
Check by (校对):	Date (日期):	Scale (比例): 1:1	
Signature by (批准):	Date (日期):	Revision (版本): A1	Sheet (页数): 1 / 1