

6	YG-C16C-0000-002	后面板	6063-T5	1	0.797	
5	YG-C16C-0000-004	侧板	6063-T5	2	0.594	
4	GB-T-819.1-2000-C-NI-M3X6	碳钢镀镍十字沉头螺丝M3X6	普通碳钢	41	0.0004	
3	YG-TY-JM-001	角码30X30X1.5	普通碳钢	8	0.005	
2	YG-C16C-0000-001	前面板	6063-T5	1	0.878	
1	YG-C16C-0000-003	盖板	5052-H32	2	0.706	
序号	图号	名称	材料	数量	单重	备注

技术要求:

- 1、必须按照设计、工艺要求及本规定和有关标准进行装配;
- 2、所有零部件(包括外购、外协件)必须具有检验合格证方能进行装配;
- 3、零件在装配前必须清理和清洗干净,不得有毛刺、飞边、氧化皮、锈蚀、切屑、砂粒、灰尘和油污等,并应符合相应清洁度要求;
- 4、装配过程中零件不得磕碰、划伤和锈蚀;
- 5、油漆未干的零件不得进行装配;
- 6、相对运动的零件,装配时接触面间应加润滑油脂;
- 7、各零、部件装配后相对位置应准确。

Break sharp edges (未注锐边倒角): Ch 0.05 to 0.25 x45°	Angular tolerances (未注角度公差): <6° ± 10' <30° ± 20' <120° ± 30' >120° ± 1°
Position tolerances (未注位置公差): ± 0.05	

Tolerances (未注公差): 0.5 to 6 ± 0.1 6 to 30 ± 0.2 30 to 120 ± 0.3 120 to 400 ± 0.4	Material (材料): (装配图)
	Weight: (重量) (Kg): 4.330
	Protection: (表面处理):
	Part Name (零/部件名称):

YONGU 永固

C16C机箱		Drawing Number (图号): YG-C16C-0000-000	
Drawn by (绘图): 邓展锋	Date (日期): 2020.05.25	Size (图幅): A0	Sheet (页数): 1 / 1
Check by (校对):	Date (日期):	Scale (比例): 1:1.5	Revision (版本): A1
Signature by (批准):	Date (日期):		

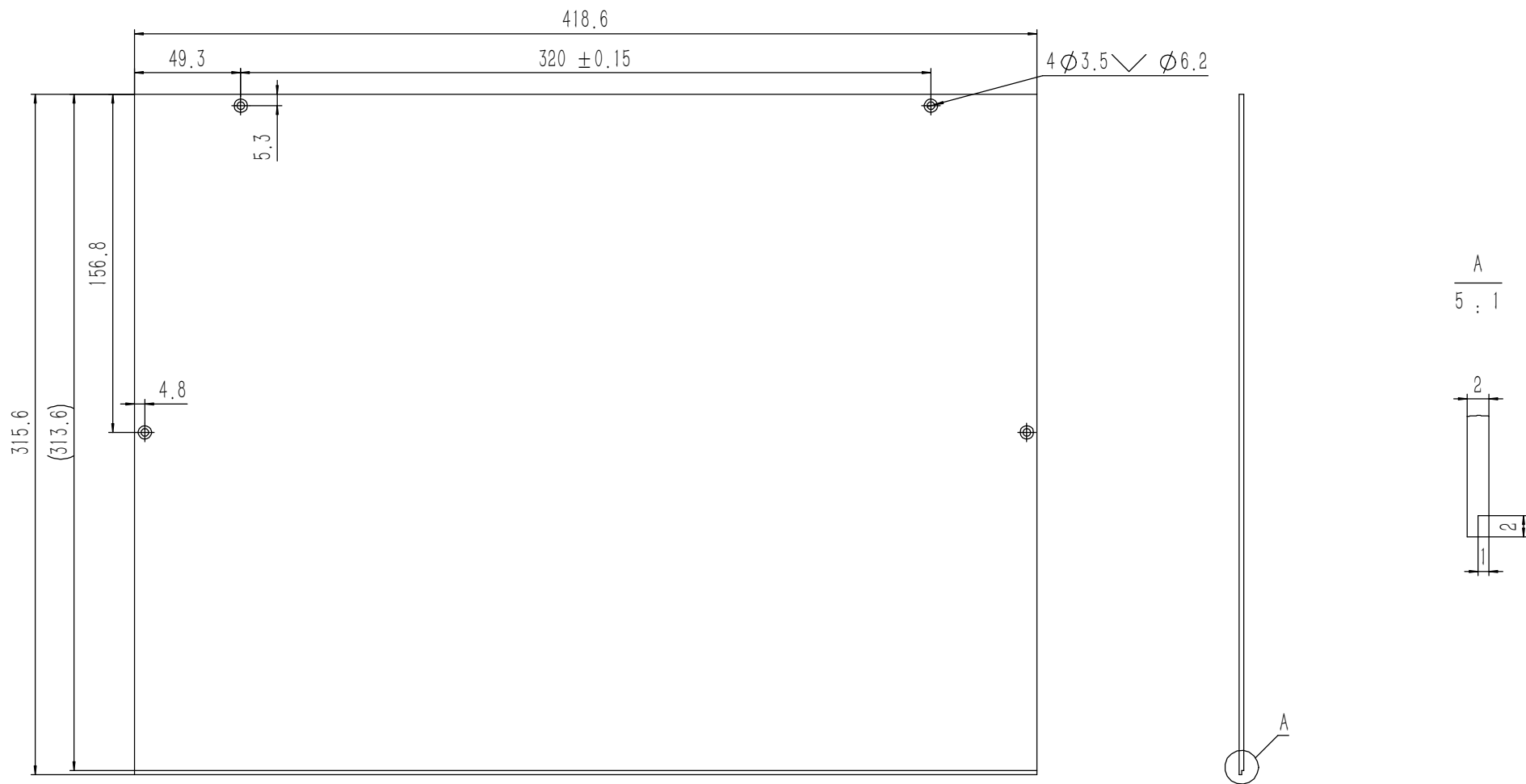

技术要求:

- 1、零件加工表面不应有划痕、擦伤等损伤零件表面的缺陷;
- 2、去除毛刺飞边,锐角倒钝;
- 3、未标注尺寸见3D数模。

Tolerances (未注公差): 0.5 to 6 ± 0.1 6 to 30 ± 0.2 30 to 120 ± 0.3 120 to 400 ± 0.4	Material (材料):	5052-H32	
	Weight: (重量) (Kg):	0.706	
Break sharp edges (未注锐边倒角): Ch 0.05 to 0.25 x45°	Protection: (表面处理):		
	Part Name (零/部件名称):	盖板	
Position tolerances (未注位置公差): ± 0.05	Angular tolerances (未注角度公差): <6° ± 10' <30° ± 20' <120° ± 30' >120° ± 1°	Drawing Number (图号):	YG-C16C-0000-003
	Drawn by (绘图): 邓展锋	Date (日期): 2020.05.26	Size: (图幅): A1
	Check by (校对):	Date (日期):	Scale (比例): 1:1
	Signature by (批准):	Date (日期):	Revision (版本): A1

YONGU 永固

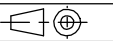

Sheet (页数):

1 / 1

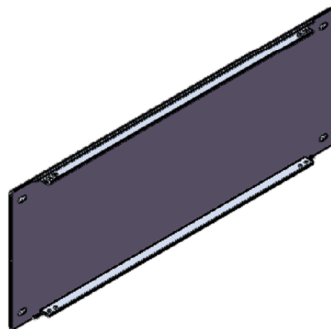
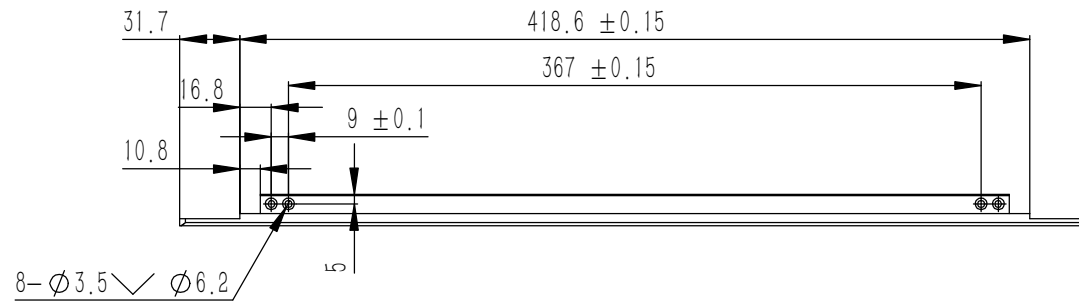
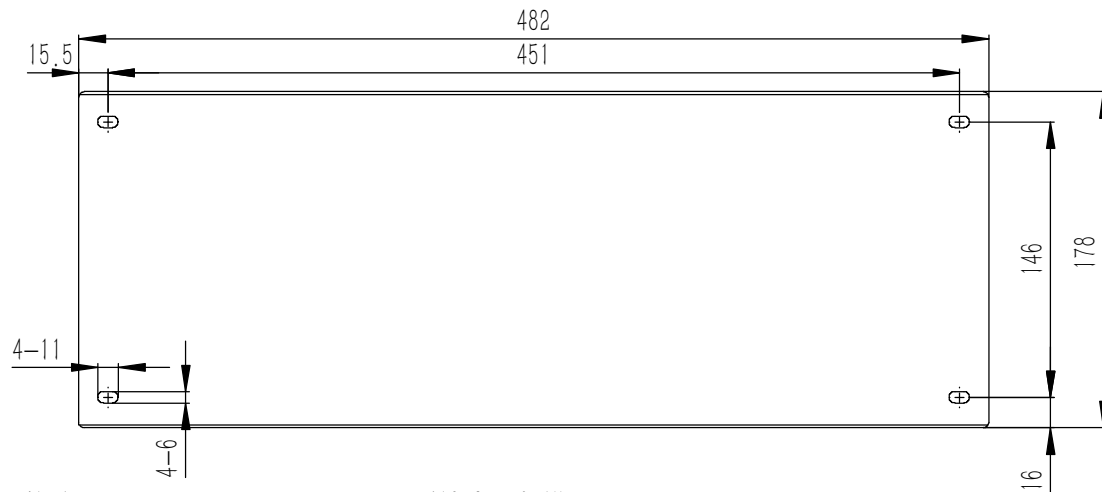
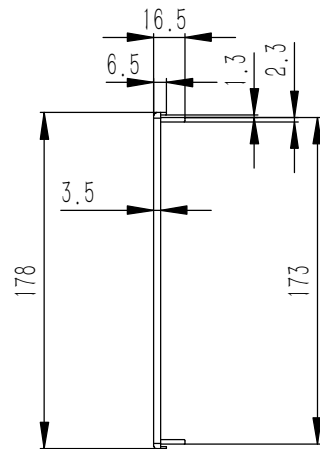

技术要求:

- 1、零件加工表面不应有划痕、擦伤等损伤零件表面的缺陷;
- 2、去除毛刺飞边,锐角倒钝;
- 3、未标注尺寸见3D数模。

Break sharp edges (未注锐边倒角): Ch 0.05 to 0.25 x45°	Angular tolerances (未注角度公差): <6° ± 10' <30° ± 20' <120° ± 30' >120° ± 1°
Position tolerances (未注位置公差): ±0.05	

Tolerances (未注公差): 0.5 to 6 ± 0.1 6 to 30 ± 0.2 30 to 120 ± 0.3 120 to 400 ± 0.4	Material (材料): 6063-T5	YONGU 永固	Drawing Number (图号): YG-C16C-0000-001	
Weight: (重量) (Kg): 0.878	Protection: (表面处理):		Size: (图幅): A0	Sheet (页数): 1 / 1
Part Name (零/部件名称):	Part Name (零/部件名称): 前面板		Scale (比例): 1:1	Revision (版本): A1
Drawn by (绘图): 邓展锋	Date (日期): 2020.05.26	Signature by (批准):	Date (日期):	Sheet (页数): 1 / 1
Check by (校对):	Date (日期):	Signature by (批准):	Date (日期):	Sheet (页数): 1 / 1

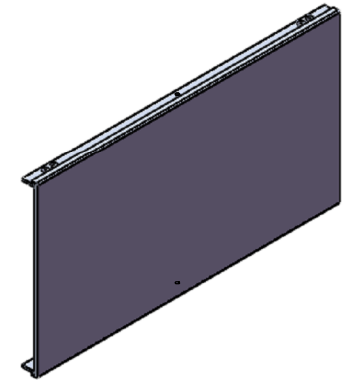
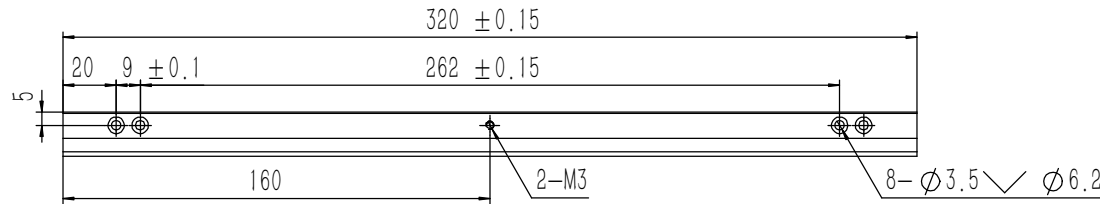
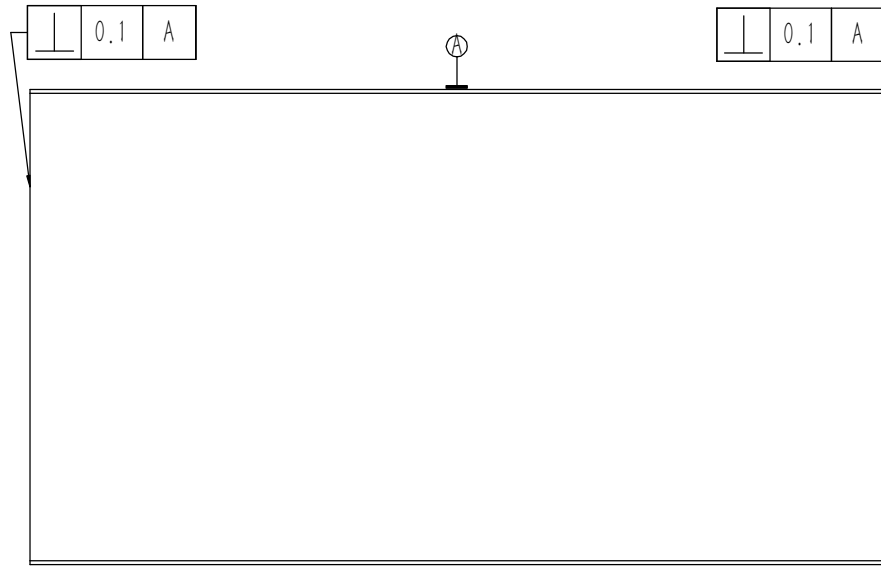
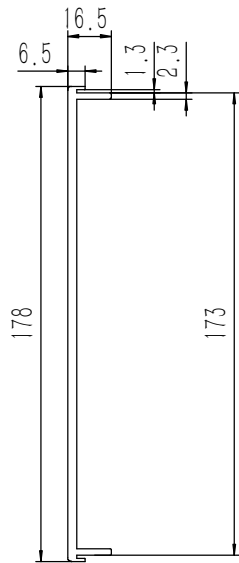

技术要求:

- 1、零件加工表面不应有划痕、擦伤等损伤零件表面的缺陷;
- 2、去除毛刺飞边,锐角倒钝;
- 3、未标注尺寸见3D数模。

Tolerances (未注公差): 0.5 to 6 ± 0.1 6 to 30 ± 0.2 30 to 120 ± 0.3 120 to 400 ± 0.4	Material (材料):	6063-T5	
	Weight: (重量) (Kg):	0.594	
	Protection: (表面处理):		
	Part Name (零/部件名称):	侧板	
Break sharp edges (未注锐边倒角): Ch 0.05 to 0.25 x45°	Angular tolerances (未注角度公差): <6° ± 10' <30° ± 20' <120° ± 30' >120° ± 1°	Drawing Number (图号): YG-C16C-0000-004	
Position tolerances (未注位置公差): ± 0.05	Drawn by (绘图): 邓展锋	Date (日期): 2020.05.26	Size: (图幅): A1
	Check by (校对):	Date (日期):	Scale (比例): 1:1
	Signature by (批准):	Date (日期):	Revision (版本): A1
			Sheet (页数): 1 / 1

YONGU 永固

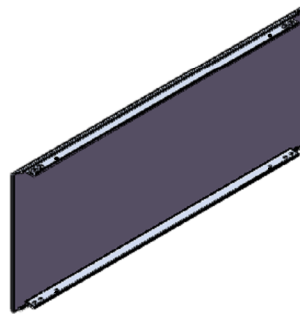
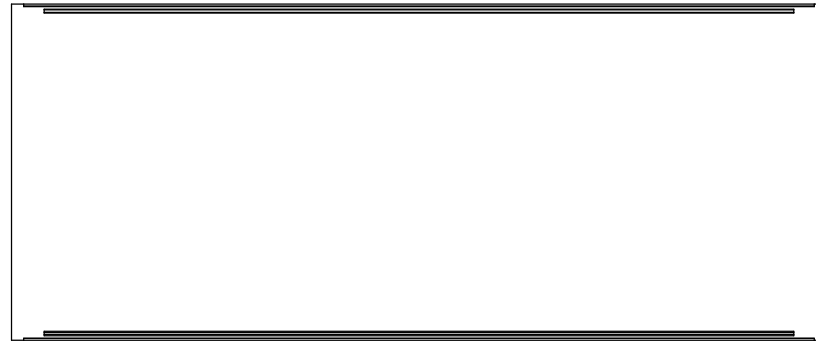
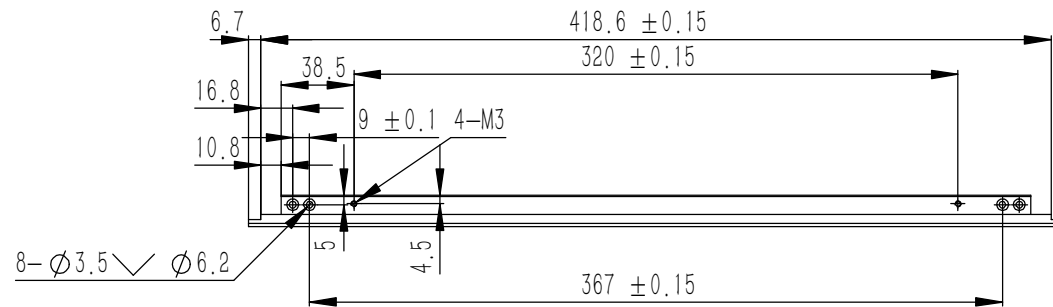
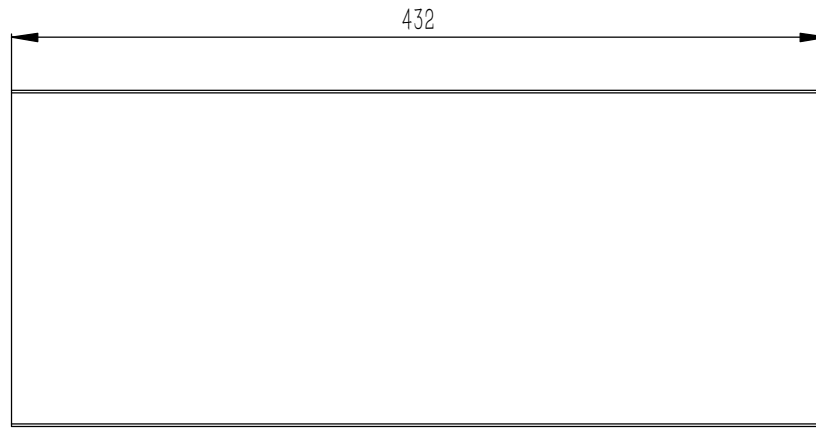
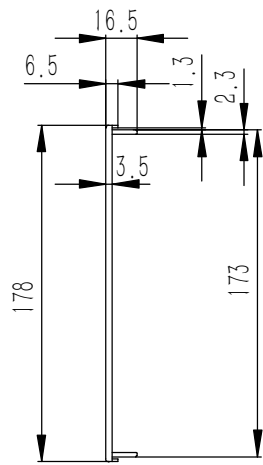

技术要求:

- 1、零件加工表面不应有划痕、擦伤等损伤零件表面的缺陷;
- 2、去除毛刺飞边, 锐角倒钝;
- 3、未标注尺寸见3D数模。

Break sharp edges (未注锐边倒角): Ch 0.05 to 0.25 x45°	Angular tolerances (未注角度公差): <6° ± 10' <30° ± 20' <120° ± 30' >120° ± 1°
Position tolerances (未注位置公差): ± 0.05	

Tolerances (未注公差):	Material (材料):	6063-T5
0.5 to 6 ± 0.1	Weight: (重量) (Kg):	0.797
6 to 30 ± 0.2	Protection: (表面处理):	
30 to 120 ± 0.3	Part Name (零/部件名称):	后面板
120 to 400 ± 0.4		

YONGU 永固

Drawing Number (图号):		YG-C16C-0000-002	
Drawn by (绘图): 邓展锋	Date (日期): 2020.05.26	Size (图幅): A0	Sheet (页数): 1 / 1
Check by (校对):	Date (日期):	Scale (比例): 1:1	
Signature by (批准):	Date (日期):	Revision (版本): A1	