

技术要求:

- 1、必须按照设计、工艺要求及本规定和有关标准进行装配;
- 2、所有零部件(包括外购、外协件)必须具有检验合格证方能进行装配;
- 3、零件在装配前必须清理和清洗干净,不得有毛刺、飞边、氧化皮、锈蚀、切屑、砂粒、灰尘和油污等,并应符合相应清洁度要求;
- 4、装配过程中零件不得磕碰、划伤和锈蚀;
- 5、油漆未干的零件不得进行装配;
- 6、相对运动的零件,装配时接触面间应加润滑油;
- 7、各零、部件装配后相对位置应准确。

序号	图号	名称	材料	数量	单重	备注
7	GB-T-819.1-2000-C-NI-M3X8	碳钢镀镍十字沉头螺丝M3X8	普通碳钢	4	0.0005	
6	GB-T-819.1-2000-C-NI-M3X6	碳钢镀镍十字沉头螺丝M3X6	普通碳钢	20	0.0004	
5	YG-C02A-0000-002	后面板	6063-T5	1	0.212	
4	YG-TY-JM-001	角码30X30X1.5	普通碳钢	4	0.005	
3	YG-C02A-0000-003	上下盖板	5052-H32	2	0.517	
2	YG-C02A-0000-004	侧板	6063-T5	2	0.216	
1	YG-C02A-0000-001	前面板	6063-T5	1	0.344	

Tolerances (未注公差):		Material (材料): (装配图)		YONGU 永固		
0.5 to 6	± 0.1	Weight: (重量) (Kg):	2.051			
6 to 30	± 0.2	Protection: (表面处理):				
30 to 120	± 0.3	Part Name (零/部件名称):	C01A机箱			
120 to 400	± 0.4	Drawing Number (图号):		YG-C02A-0000-000		
Break sharp edges (未注锐边倒角): Ch 0.05 to 0.25 x45°	Angular tolerances (未注角度公差): <6° ± 10' <30° ± 20' <120° ± 30' >120° ± 1°	Position tolerances (未注位置公差): ± 0.05	Drawn by (绘图): 邓展锋	Date (日期): 2020.05.25	Size (图幅): A0	Sheet (页数): 1 / 1
			Check by (校对):	Date (日期):	Scale (比例): 1:1	Revision (版本): A1
			Signature by (批准):	Date (日期):		

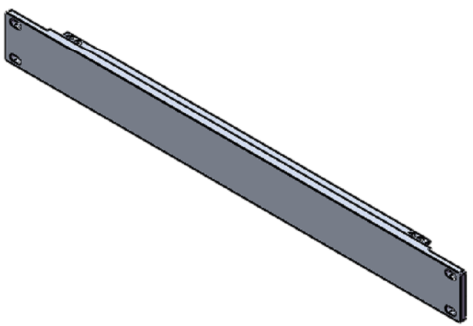
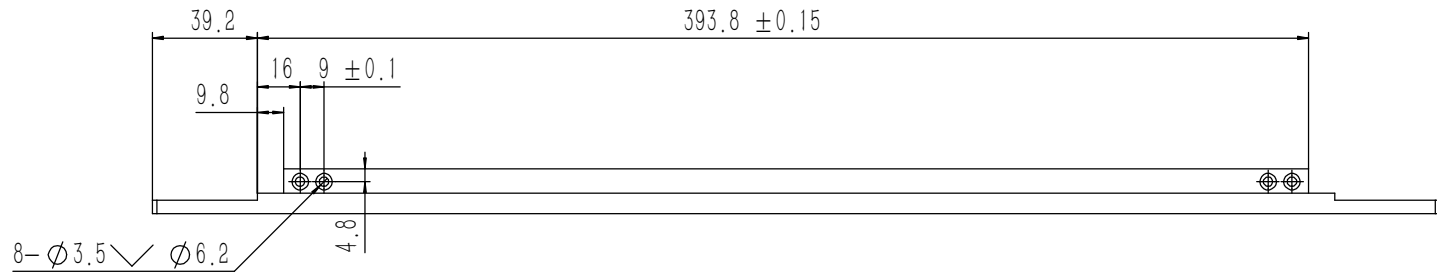
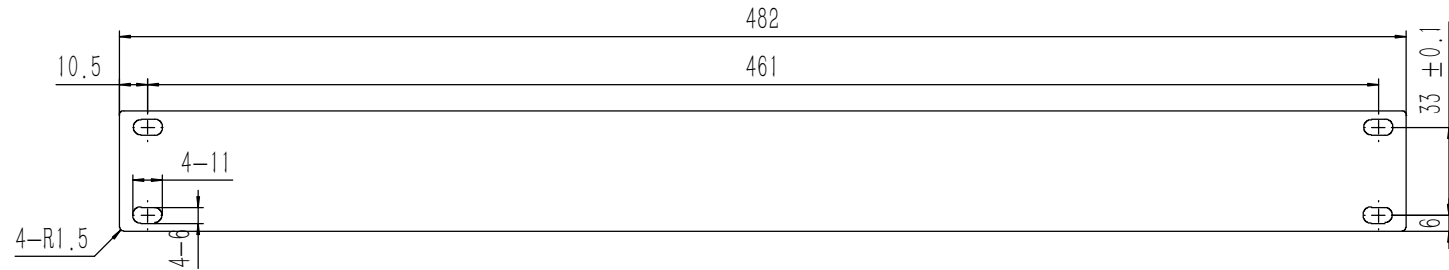
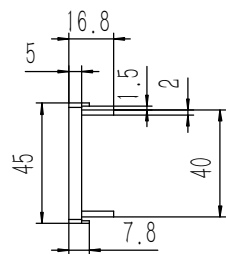

技术要求:
 1、零件加工表面不应有划痕、擦伤等损伤零件表面的缺陷;
 2、去除毛刺飞边, 锐角倒钝;
 3、未标注尺寸见3D数模。

Tolerances (未注公差): 0.5 to 6 ± 0.1 6 to 30 ± 0.2 30 to 120 ± 0.3 120 to 400 ± 0.4	Material (材料):	6063-T5		YONGU 永固
	Weight: (重量) (Kg):	0.344		
Break sharp edges (未注锐边倒角): Ch 0.05 to 0.25 x45°	Protection: (表面处理):			
	Position tolerances (未注位置公差): ± 0.05	Part Name (零/部件名称):	前面板	
Angular tolerances (未注角度公差): <6° ± 10' <30° ± 20' <120° ± 30' >120° ± 1°	Part Name (零/部件名称):	前面板		Drawing Number (图号):
	Drawn by (绘图):	邓展锋	Date (日期):	2020.05.25
	Check by (校对):		Date (日期):	
	Signature by (批准):		Date (日期):	
		Size: (图幅):	A1	Sheet (页数):
		Scale (比例):	1:1	1 / 1
		Revision (版本):	A1	

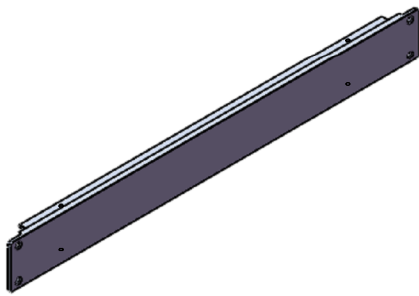
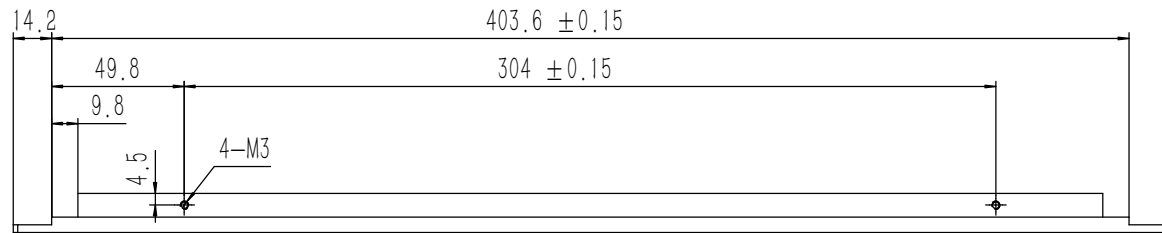
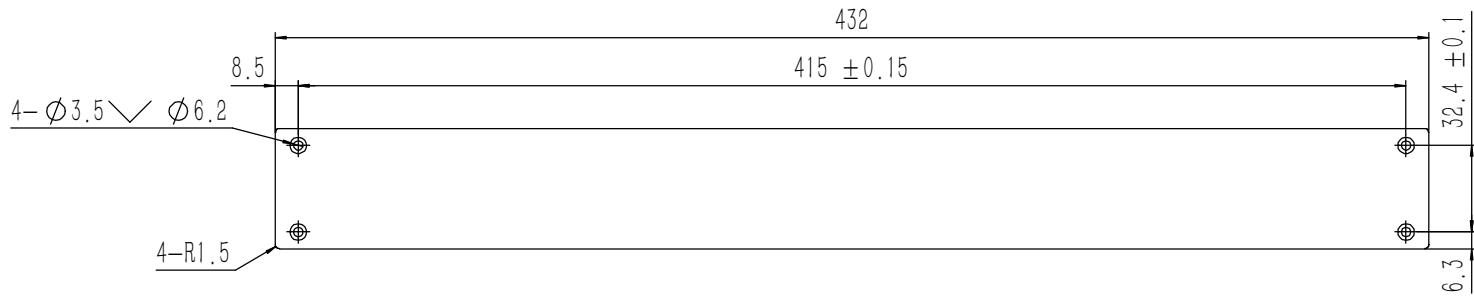
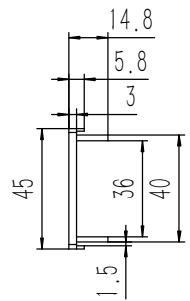

技术要求:

- 1、零件加工表面不应有划痕、擦伤等损伤零件表面的缺陷;
- 2、去除毛刺飞边, 锐角倒钝;
- 3、未标注尺寸见3D数模。

Tolerances (未注公差): 0.5 to 6 ± 0.1 6 to 30 ± 0.2 30 to 120 ± 0.3 120 to 400 ± 0.4	Material (材料):	6063-T5	YONGU 永固					
	Weight: (重量) (Kg):	0.212						
Break sharp edges (未注锐边倒角): Ch 0.05 to 0.25 x45°	Protection: (表面处理):		Drawing Number (图号): YG-C02A-0000-002					
	Angular tolerances (未注角度公差): <6° ± 10' <30° ± 20' <120° ± 30' >120° ± 1°	Part Name (零/部件名称):		后面板				
Position tolerances (未注位置公差): ± 0.05	Drawn by (绘图):	邓展锋	Date (日期):	2020.05.25	Size: (图幅):	A1	Sheet (页数):	1 / 1
	Check by (校对):		Date (日期):		Scale (比例):	1:1		
	Signature by (批准):		Date (日期):		Revision (版本):	A1		

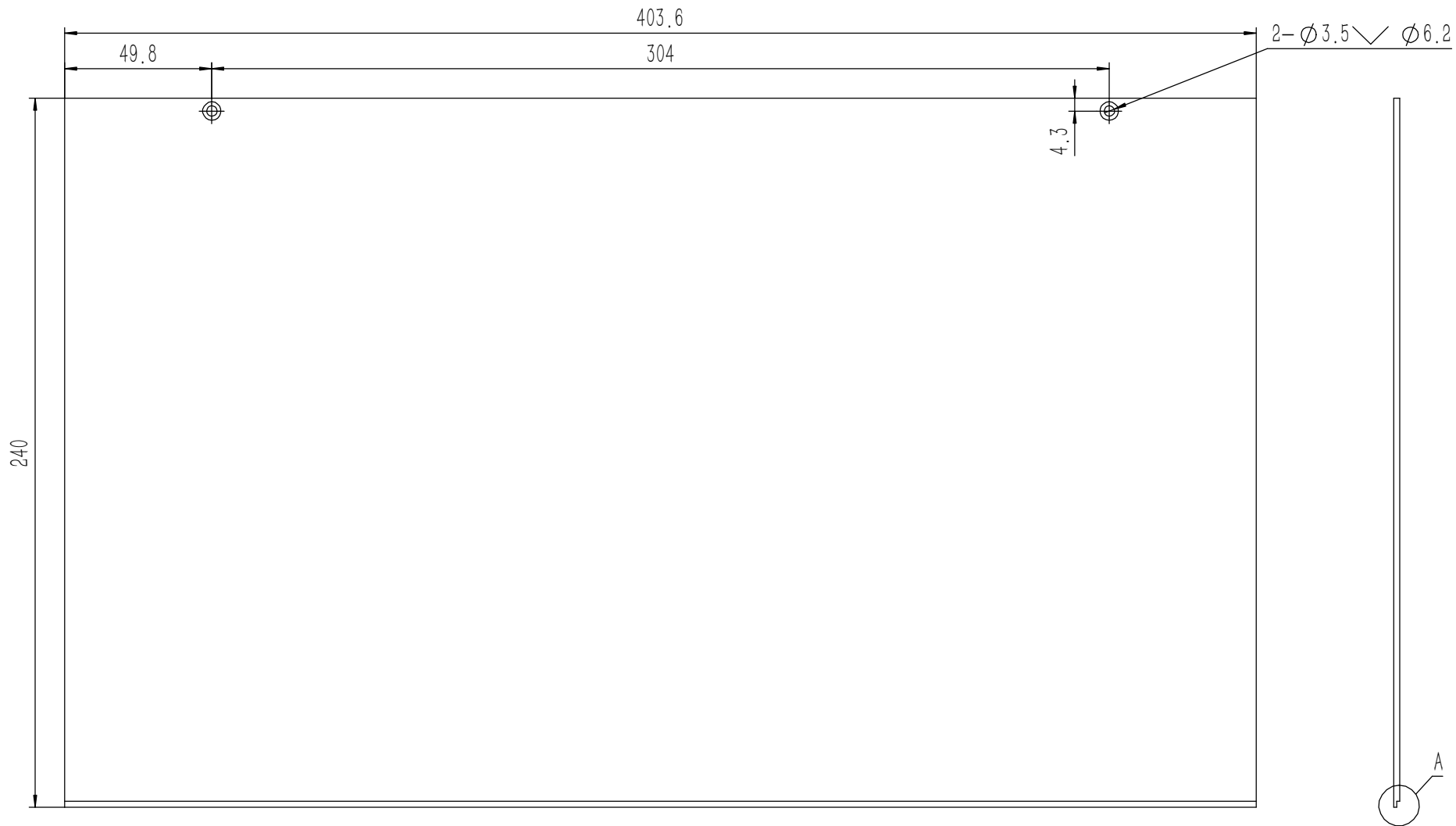

A
5 : 1

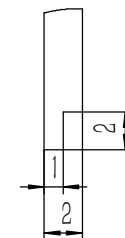

技术要求:

- 1、零件加工表面不应有划痕、擦伤等损伤零件表面的缺陷;
- 2、去除毛刺飞边, 锐角倒钝;
- 3、未标注尺寸见3D数模。

Tolerances (未注公差): 0.5 to 6 ± 0.1 6 to 30 ± 0.2 30 to 120 ± 0.3 120 to 400 ± 0.4	Material (材料):	5052-H32		YONGU 永固				
	Weight: (重量) (Kg):	0.517						
Break sharp edges (未注锐边倒角): Ch 0.05 to 0.25 x45°	Protection: (表面处理):			Drawing Number (图号): YG-C02A-0000-003				
	Part Name (零/部件名称):	上下盖板						
Position tolerances (未注位置公差): ±0.05	Angular tolerances (未注角度公差): <6° ± 10' <30° ± 20' <120° ± 30' >120° ± 1°	Drawn by (绘图):	邓展锋	Date (日期):	2020.05.25	Size: (图幅):	A2	Sheet (页数): 1 / 1
		Check by (校对):		Date (日期):		Scale (比例):	1:1	
		Signature by (批准):		Date (日期):		Revision (版本):	A1	

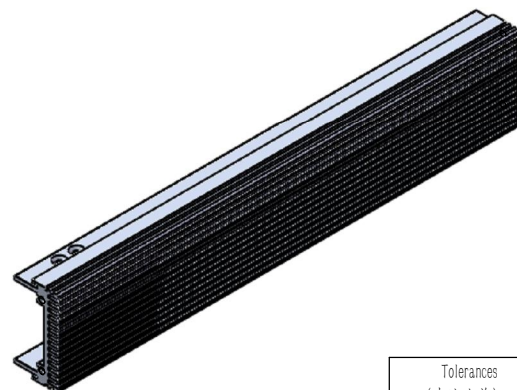
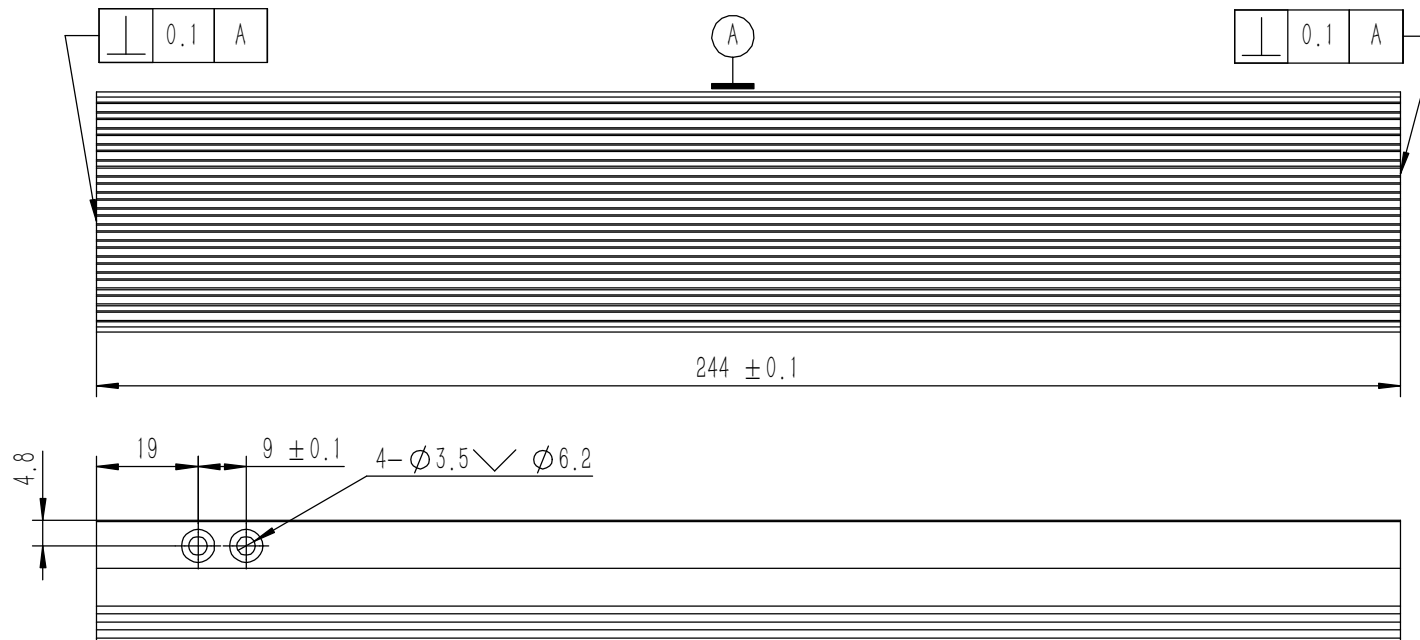
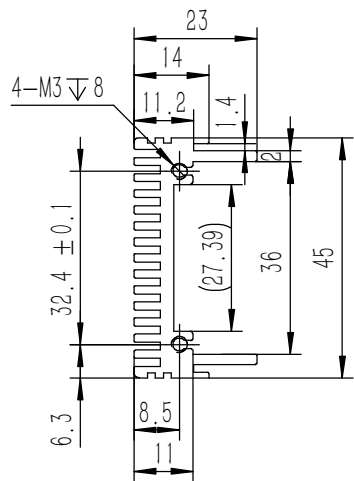

技术要求:

- 1、零件加工表面不应有划痕、擦伤等损伤零件表面的缺陷;
- 2、去除毛刺飞边, 锐角倒钝;
- 3、未标注尺寸见3D数模。

业务代码:

Break sharp edges (未注锐边倒角): Ch 0.05 to 0.25 x45°	Angular tolerances (未注角度公差): <6° ± 10' <30° ± 20' <120° ± 30' >120° ± 1°
Position tolerances (未注位置公差): ±0.05	

Tolerances (未注公差): 0.5 to 6 ± 0.1 6 to 30 ± 0.2 30 to 120 ± 0.3 120 to 400 ± 0.4	Material (材料): 6063-T5	YONGU 永固
	Weight: (重量) (Kg) 0.216	
	Protection: (表面处理):	Drawing Number (图号): YG-C02A-0000-004
	Part Name (零/部件名称): 侧板	
	Drawn by (绘图): 邓展锋	Date (日期): 2020.05.25
	Check by (校对):	Date (日期):
	Signature by (批准):	Date (日期):
	Size (图幅): A3	Scale (比例): 1:1
	Revision (版本): A2	Sheet (页数): 1 / 1