

8	GB-T-70.1-2000-C-BE-M3X8	碳钢发黑内六角杯头螺丝M3X8	普通碳钢	16	0.001	
7	YG-S-2-06	黑色大包角	黑色 TPE 90A	8	0.032	
6	GB-T-39-1988-C-ZI-M3	方螺母镀白锌M3	普通碳钢	8	0.0004	
5	GB-T-70.3-2000-C-NB-M3X6	芳生镀黑镍内六角沉头螺丝M3X6	普通碳钢	8	0.0004	
4	YG-TY-LMT-002	塑料螺母套 M3	ABS	8	0.0001	
3	YG-S205-0000-003	挡板	5052-H32	2	0.108	
2	YG-S205-0000-002	上下盖板	5052-H32	2	0.666	
1	YG-S205-0000-001	连接条	6063-T5	2	0.049	
序号 (Item)	图号 (Drawing Number)	名称 (Part Name)	材料 (Material)	数量 (QTY)	单重 (Weight)	备注 (Note)

Tolerances (未注公差):		Material (材料): (装配图)		<b>YONGU</b> 永固	
0.5 to 6 ± 0.1		Weight (重量) (Kg): 1.925			
6 to 30 ± 0.2		Protection: (表面处理):			
30 to 120 ± 0.3		Part Name (零/部件名称):			
120 to 400 ± 0.4		S205大包角机箱		Drawing Number (图号): YG-S205-0000-000	
Break sharp edges (未注锐边倒角): Ch 0.05 to 0.25 x45°		Angular tolerances (未注角度公差): <6° ± 10'		Drawn by (绘图): 江瑞章	
		<30° ± 20'		Date (日期): 2021.06.03	
		<120° ± 30'		Check by (校对):	
		>120° ± 1°		Date (日期):	
Position tolerances (未注位置公差): ±0.05		Signature by (批准):		Date (日期):	
				Size (图幅): A0	
				Scale (比例): 1:1	
				Revision (版本): A1	
				Sheet (页数): 1 / 1	

技术要求:

- 1、必须按照设计、工艺要求及本规定和有关标准进行装配;
- 2、所有零部件(包括外购、外协件)必须具有检验合格证方能进行装配;
- 3、零件在装配前必须清理和清洗干净,不得有毛刺、飞边、氧化皮、锈蚀、切屑、砂粒、灰尘和油污等,并应符合相应清洁度要求;
- 4、装配过程中零件不得磕碰、划伤和锈蚀;
- 5、油漆未干的零件不得进行装配;
- 6、相对运动的零件,装配时接触面间应加润滑油脂;
- 7、各零、部件装配后相对位置应准确。

业务代码: 210-135

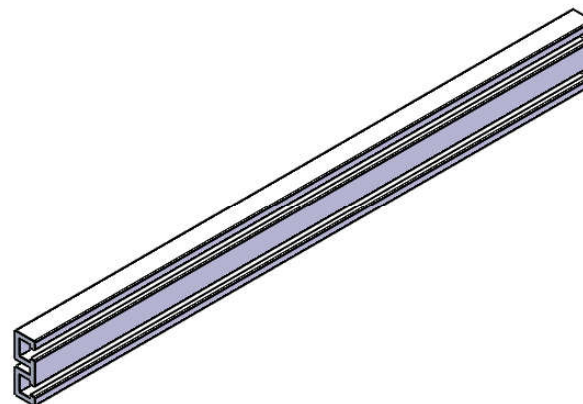
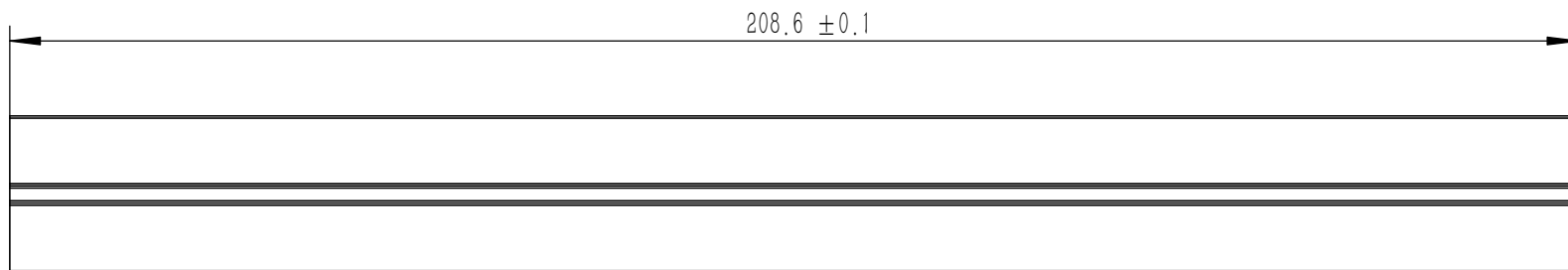
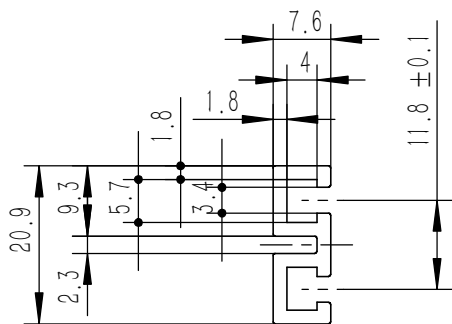

技术要求:

- 1、未注倒角R0.3, 未标锐边的倒角不超R0.1
- 2、零件加工表面不应有划痕、擦伤等损伤零件表面的缺陷;
- 3、未标注尺寸见电子档图纸

业务代码: 210-135

Tolerances (未注公差): 0,5 to 6 ± 0,1 6 to 30 ± 0,2 30 to 120 ± 0,3 120 to 400 ± 0,4	Material (材料): 6063-T5	<b>YONGU</b> 永固	
	Weight: (重量) (Kg) 0.049		
Break sharp edges (未注锐边倒角): Ch 0,05 to 0,25 x45°	Protection: (表面处理):	Part Name (零/部件名称):	
	Position tolerances (未注位置公差): ±0,05	连接条	
Angular tolerances (未注角度公差): <6° ± 10' <30° ± 20' <120° ± 30' >120° ± 1°	Part Name (零/部件名称):	Drawing Number (图号):	
	Drawn by (绘图): 江瑞章	Date (日期): 2021.06.03	YG-S205-0000-001
Position tolerances (未注位置公差): ±0,05	Check by (校对):	Date (日期):	Scale (比例): 1:1
	Signature by (批准):	Date (日期):	Revision (版本): A1
		Sheet (页数):	1 / 1

钣金展开及折弯方向参考图 (视图比例1:1)

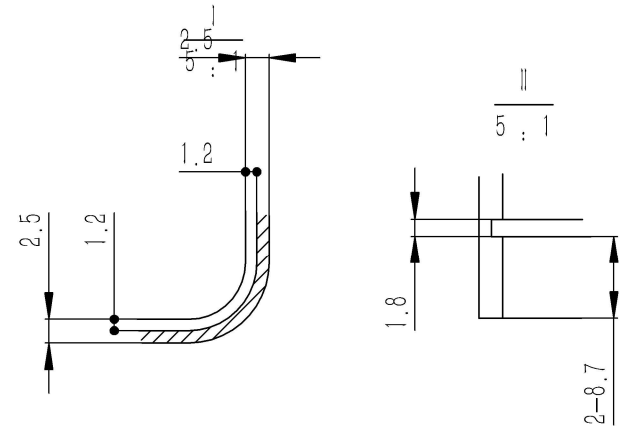
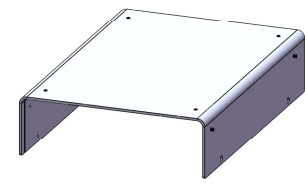
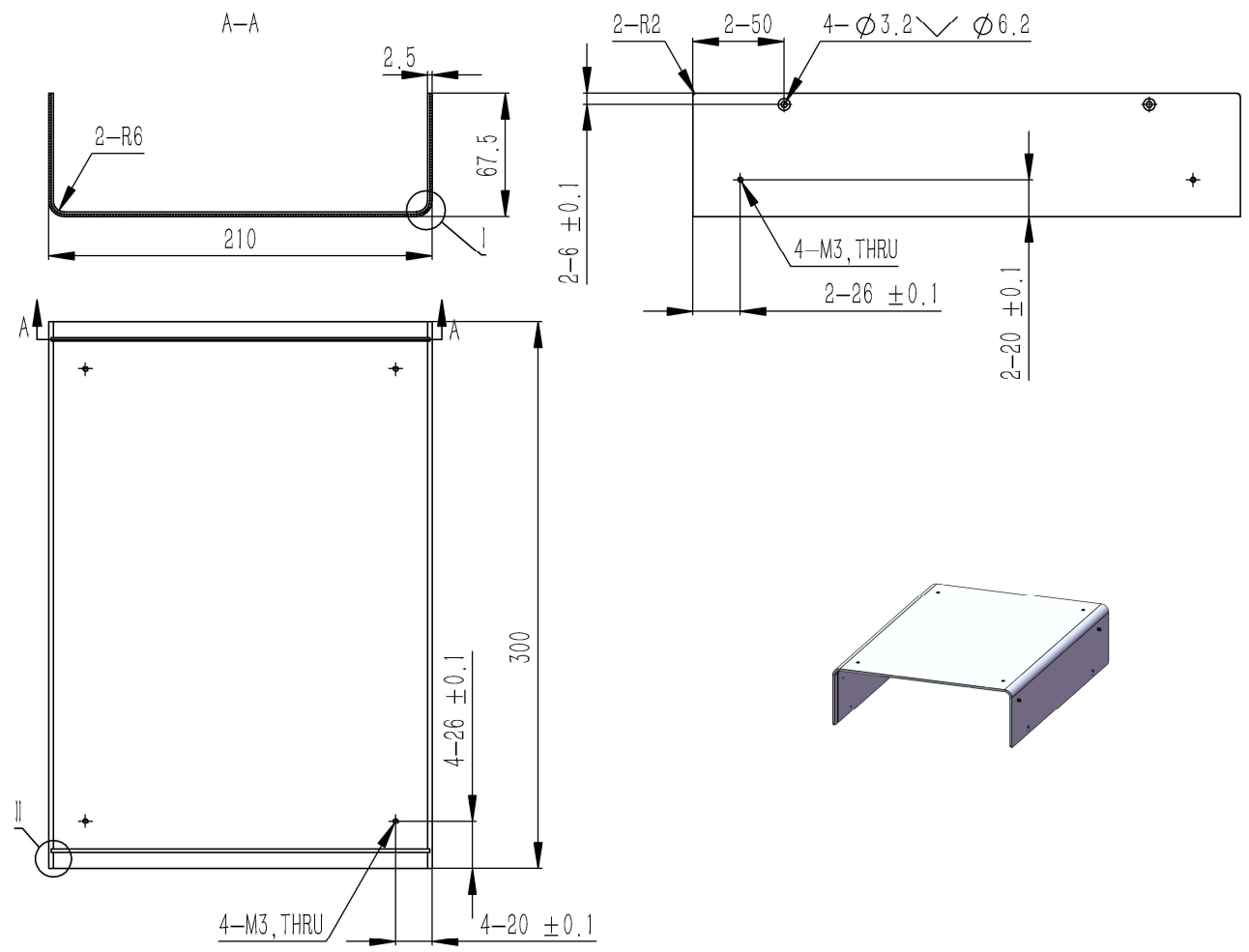
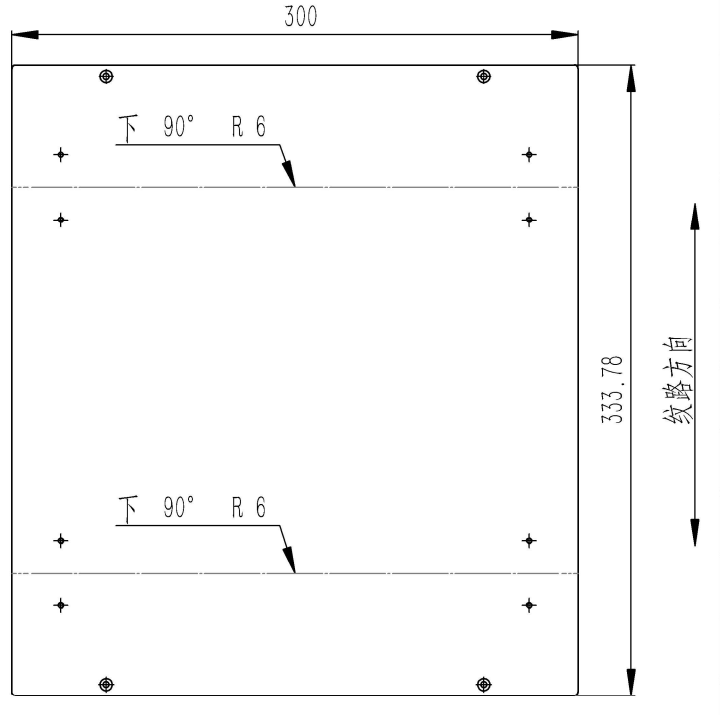

技术要求:  
 1、零件加工表面不应有划痕、擦伤等损伤零件表面的缺陷;  
 2、去除毛刺飞边,锐角倒钝;  
 3、未标注尺寸见3D数模。

业务代码: 210-135

Tolerances (未注公差): 0.5 to 6 ± 0.1 6 to 30 ± 0.2 30 to 120 ± 0.3 120 to 400 ± 0.4	Material (材料):	5052-H32		<b>YONGU</b> 永固
	Weight: (重量) (Kg):	0.666		
Break sharp edges (未注锐边倒角): Ch 0.05 to 0.25 x45°	Protection: (表面处理):			Drawing Number (图号): YG-S205-0000-002
	Position tolerances (未注位置公差): ±0.05	Part Name (零/部件名称):	上下盖板	
Angular tolerances (未注角度公差): <6° ± 10' <30° ± 20' <120° ± 30' >120° ± 1°	Drawn by (绘图):	江瑞章	Date (日期):	2021.06.03
	Check by (校对):		Date (日期):	
	Signature by (批准):		Date (日期):	
		Size (图幅):	A0	Sheet (页数):
		Scale (比例):	1:1	1 / 1
		Revision (版本):	A1	

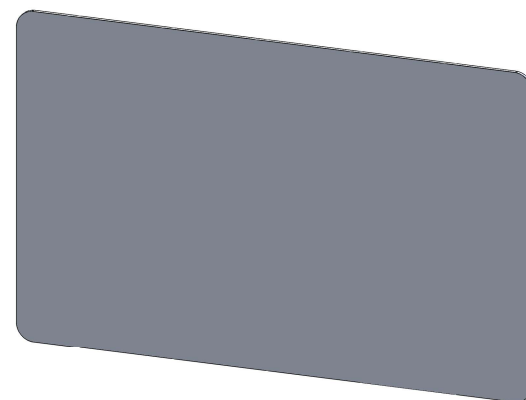
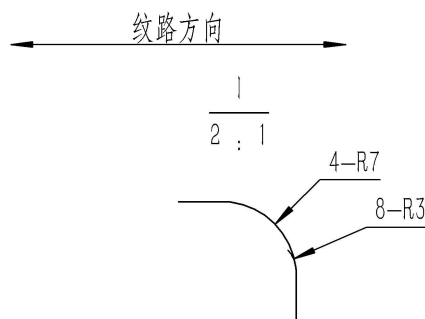
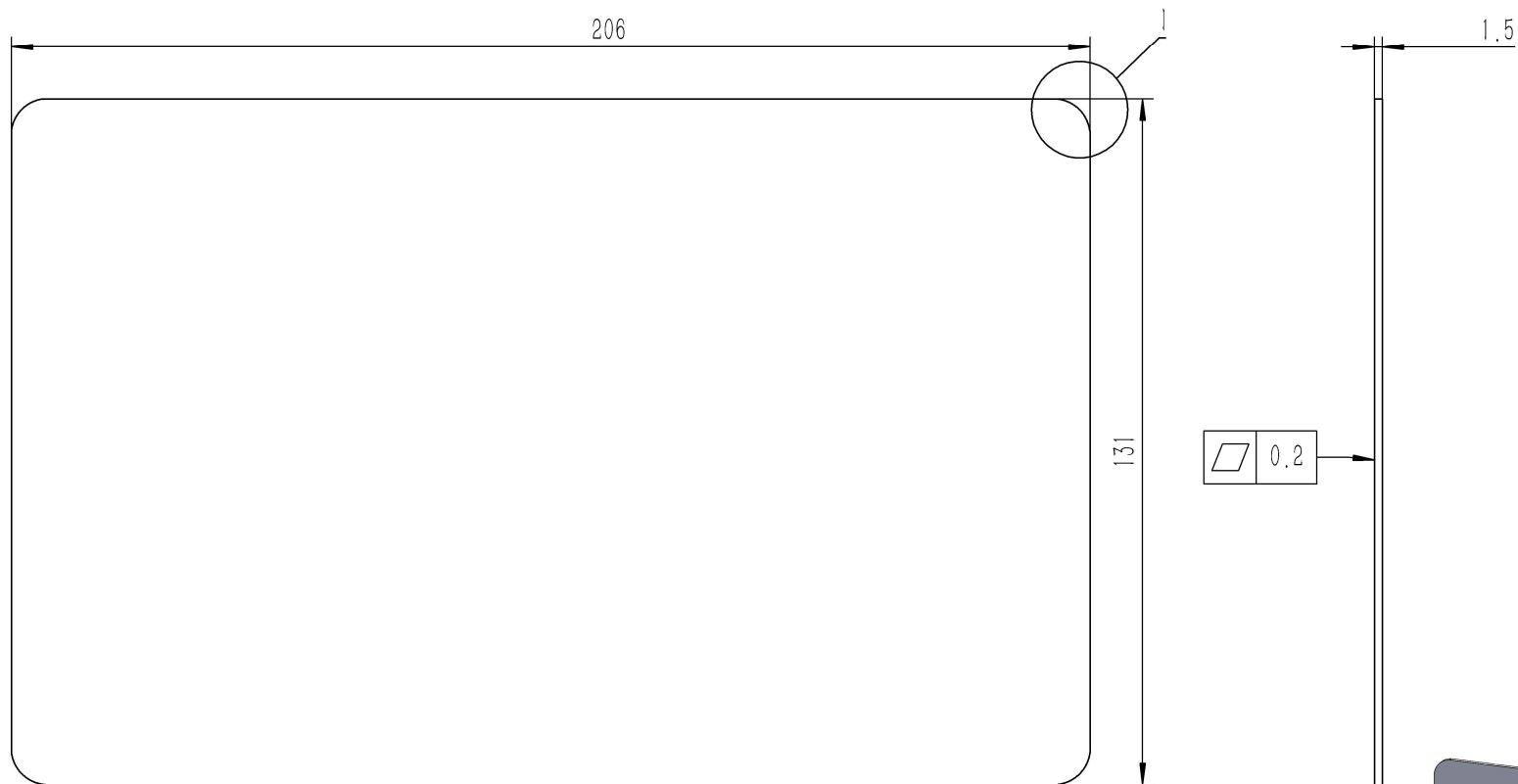

技术要求:

- 1、零件加工表面不应有划痕、擦伤等损伤零件表面的缺陷;
- 2、去除毛刺飞边,锐角倒钝;
- 3、未标注尺寸见3D数模。

业务代码: 210-135

Break sharp edges (未注锐边倒角): Ch 0.05 to 0.25 x45°	Angular tolerances (未注角度公差): <6° ± 10' <30° ± 20' <120° ± 30' >120° ± 1°
Position tolerances (未注位置公差): ±0.05	

Tolerances (未注公差): 0.5 to 6 ± 0.1 6 to 30 ± 0.2 30 to 120 ± 0.3 120 to 400 ± 0.4	Material (材料): 5052-H32	<b>YONGU</b> 永固
	Weight: (重量) (Kg) 0.108	
Protection: (表面处理):	Part Name (零/部件名称): 挡板	Drawing Number (图号): YG-S205-0000-003
Drawn by (绘图): 江瑞章	Date (日期): 2021.06.03	Size (图幅): A3
Check by (校对):	Date (日期):	Scale (比例): 1:1
Signature by (批准):	Date (日期):	Revision (版本): A1
		Sheet (页数): 1 / 1