

- 技术要求:
- 1、必须按照设计、工艺要求及本规定和有关标准进行装配;
 - 2、所有零部件(包括外购、外协件)必须具有检验合格证方能进行装配;
 - 3、零件在装配前必须清理和清洗干净,不得有毛刺、飞边、氧化皮、锈蚀、切屑、砂粒、灰尘和油污等,并应符合相应清洁度要求;
 - 4、装配过程中零件不得磕碰、划伤和锈蚀;
 - 5、油漆未干的零件不得进行装配;
 - 6、相对运动的零件,装配时接触面间应加润滑油;
 - 7、各零、部件装配后相对位置应准确。

7	GB-T-819.1-2000-C-NI-M3X8	碳钢镀镍十字沉头螺丝M3X8	普通碳钢	4	0.0005	
6	GB-T-819.1-2000-C-NI-M3X6	碳钢镀镍十字沉头螺丝M3X6	普通碳钢	20	0.0004	
5	YG-C01A-0000-002	后面板	6063-T5	1	0.212	
4	YG-TY-JM-001	角码30X30X1.5	普通碳钢	4	0.005	
3	YG-C01A-0000-003	上下盖板	5052-H32	2	0.517	
2	YG-C01A-0000-004	侧板	6063-T5	2	0.216	
1	YG-C01A-0000-001	前面板	6063-T5	1	0.228	
序号	图号	名称	材料	数量	单重	备注

Tolerances (未注公差): 0.5 to 6 ± 0.1 6 to 30 ± 0.2 30 to 120 ± 0.3 120 to 400 ± 0.4	Material (材料):	(装配图)	
	Weight: (重量) (Kg):	1.935	
	Protection: (表面处理):		
	Part Name (零/部件名称):	C01A机箱	
Break sharp edges (未注锐边倒角): Ch 0.05 to 0.25 x45°	Angular tolerances (未注角度公差): <6° ± 10' <30° ± 20' <120° ± 30' >120° ± 1°	Position tolerances (未注位置公差): ± 0.05	Drawing Number (图号): YG-C01A-0000-000
Drawn by (绘图): 邓展锋	Date (日期): 2020.05.25	Size (图幅): A0	
Check by (校对):	Date (日期):	Scale (比例): 1:1	Sheet (页数):
Signature by (批准):	Date (日期):	Revision (版本): A1	1 / 1

YONGU 永固

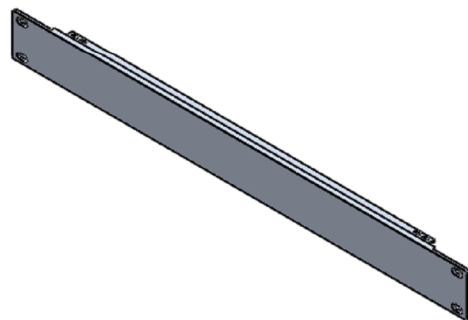
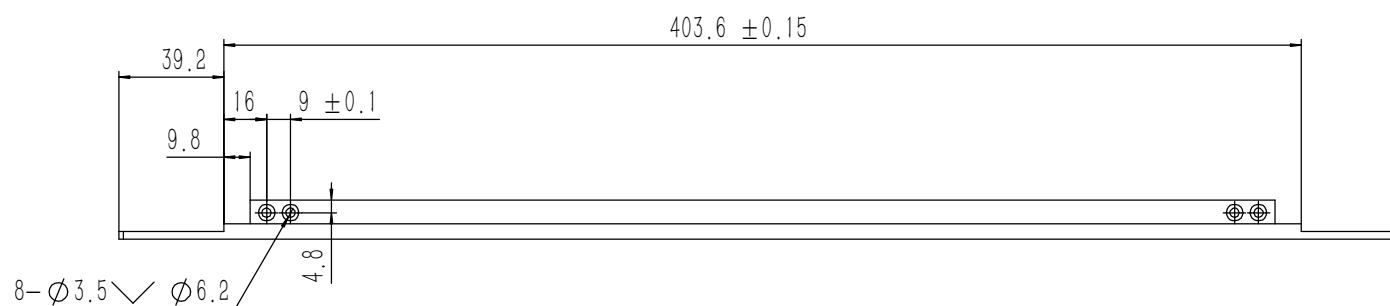
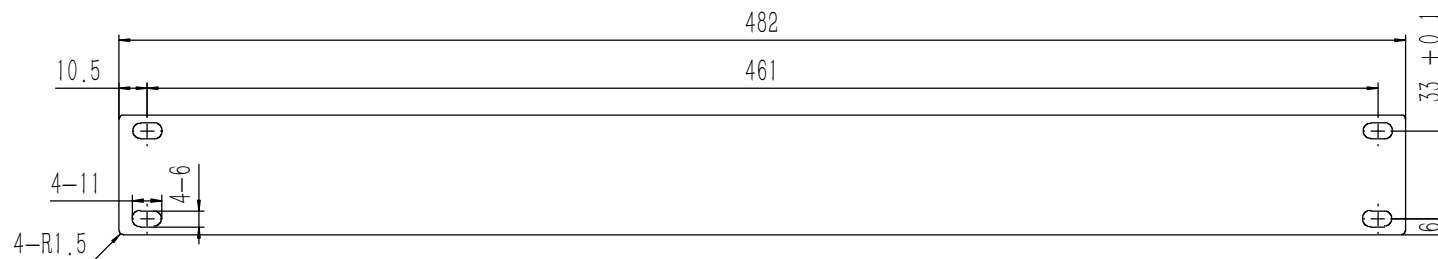
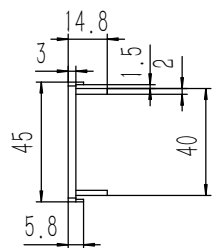

技术要求:

- 1、零件加工表面不应有划痕、擦伤等损伤零件表面的缺陷;
- 2、去除毛刺飞边,锐角倒钝;
- 3、未标注尺寸见3D数模。

Tolerances (未注公差): 0.5 to 6 ± 0.1 6 to 30 ± 0.2 30 to 120 ± 0.3 120 to 400 ± 0.4	Material (材料):	6063-T5	YONGU 永固			
	Weight: (重量) (Kg):	0.228				
Break sharp edges (未注锐边倒角): Ch 0.05 to 0.25 x45°	Protection: (表面处理):		Drawing Number (图号): YG-C01A-0000-001			
	Position tolerances (未注位置公差): ± 0.05	Part Name (零/部件名称): 前面板				
Angular tolerances (未注角度公差): <6° ± 10' <30° ± 20' <120° ± 30' >120° ± 1°	Drawn by (绘图):	邓展锋	Date (日期):	2020.05.24	Size: (图幅):	A1
	Signature by (批准):		Date (日期):		Scale (比例):	1:1
			Date (日期):		Revision (版本):	A1
					Sheet (页数):	1 / 1

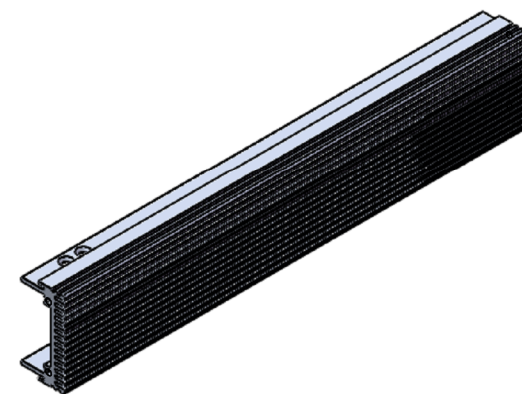
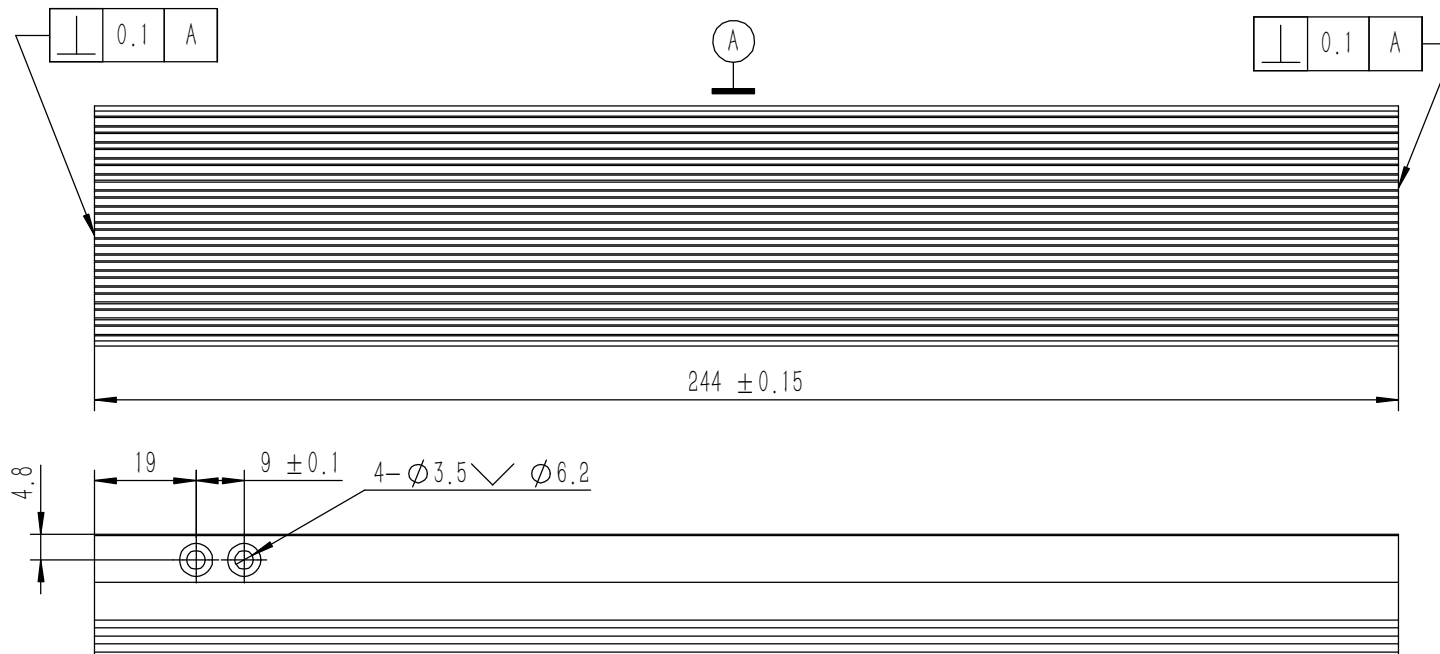
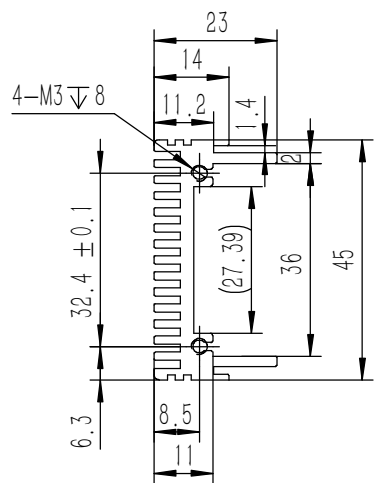

- 技术要求:
- 1、零件加工表面不应有划痕、擦伤等损伤零件表面的缺陷;
 - 2、去除毛刺飞边, 锐角倒钝;
 - 3、未标注尺寸见3D数模。

Tolerances (未注公差):	0.5 to 6	± 0.1	Material (材料):	6063-T5	YONGU 永固				
	6 to 30	± 0.2	Weight: (重量) (Kg)	0.216					
Break sharp edges (未注锐边倒角): Ch 0.05 to 0.25 x45°	30 to 120	± 0.3	Protection: (表面处理):		Drawing Number (图号): YG-C01A-0000-004				
	120 to 400	± 0.4	Part Name (零/部件名称):	侧板					
Position tolerances (未注位置公差): ± 0.05	Angular tolerances (未注角度公差):		Drawn by (绘图):	邓展锋	Date (日期):	2020.05.25	Size (图幅):	A3	Sheet (页数): 1 / 1
	<6°	± 10'	Check by (校对):		Date (日期):		Scale (比例):	1:1	
	<30°	± 20'	Signature by (批准):		Date (日期):		Revision (版本):	A1	
	<120°	± 30'							
	>120°	± 1°							

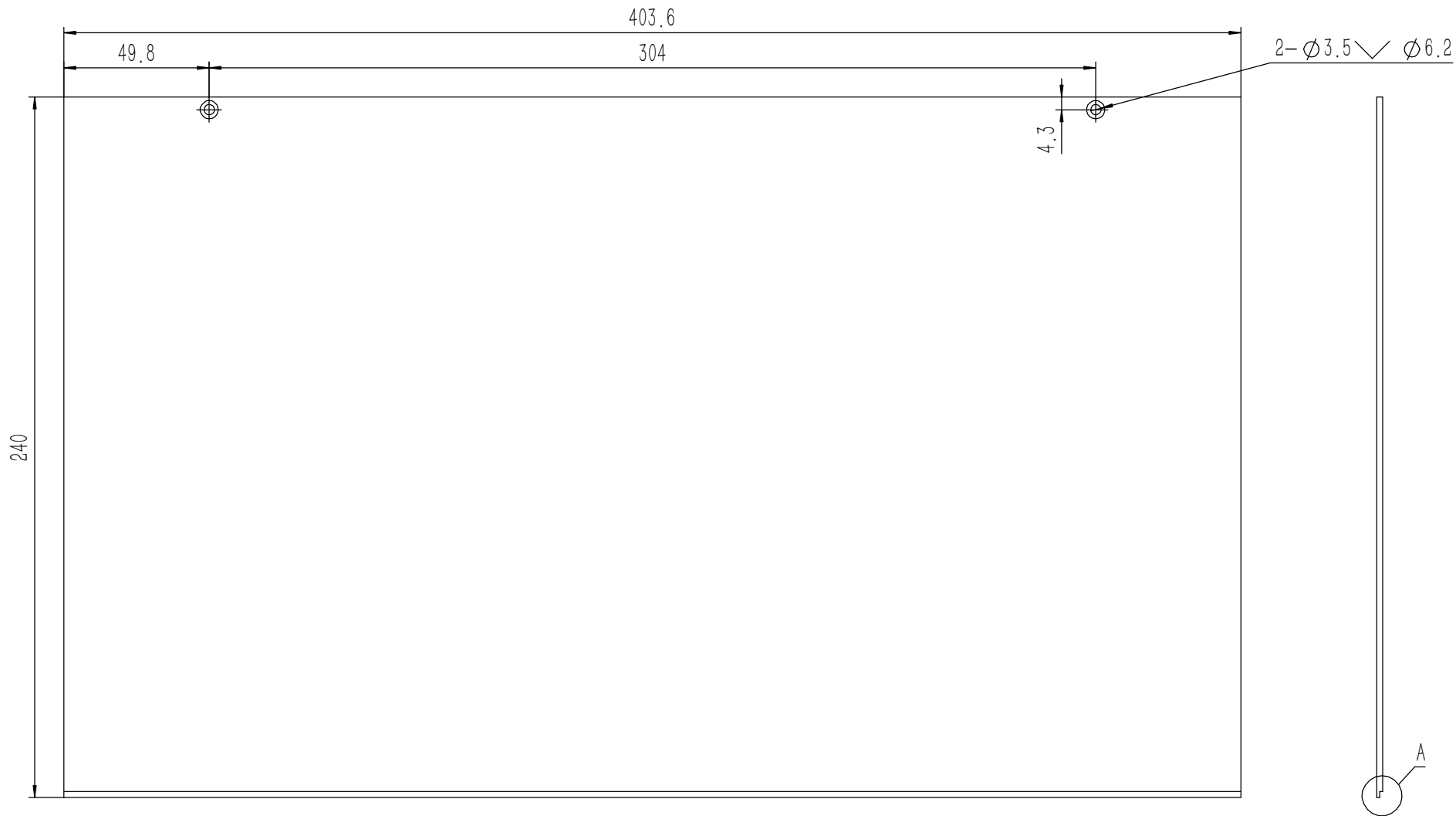

技术要求:

- 1、零件加工表面不应有划痕、擦伤等损伤零件表面的缺陷;
- 2、去除毛刺飞边,锐角倒钝;
- 3、未标注尺寸见3D数模。

Tolerances (未注公差): 0.5 to 6 ± 0.1 6 to 30 ± 0.2 30 to 120 ± 0.3 120 to 400 ± 0.4	Material (材料):	5052-H32		YONGU 永固				
	Weight: (重量) (Kg):	0.517						
Break sharp edges (未注锐边倒角): Ch 0.05 to 0.25 x45°	Protection: (表面处理):			Drawing Number (图号): YG-C01A-0000-003				
	Part Name (零/部件名称):	上下盖板						
Position tolerances (未注位置公差): ±0.05	Angular tolerances (未注角度公差): <6° ± 10' <30° ± 20' <120° ± 30' >120° ± 1°	Drawn by (绘图):	邓展锋	Date (日期):	2020.05.25	Size: (图幅):	A2	Sheet (页数): 1 / 1
		Check by (校对):		Date (日期):		Scale (比例):	1:1	
		Signature by (批准):		Date (日期):		Revision (版本):	A1	

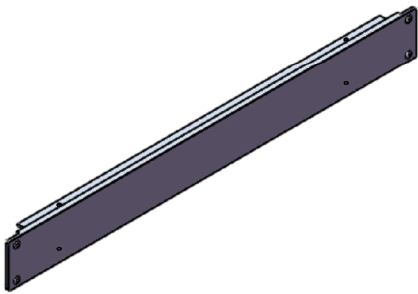
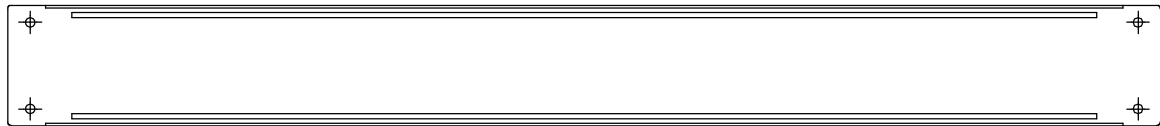
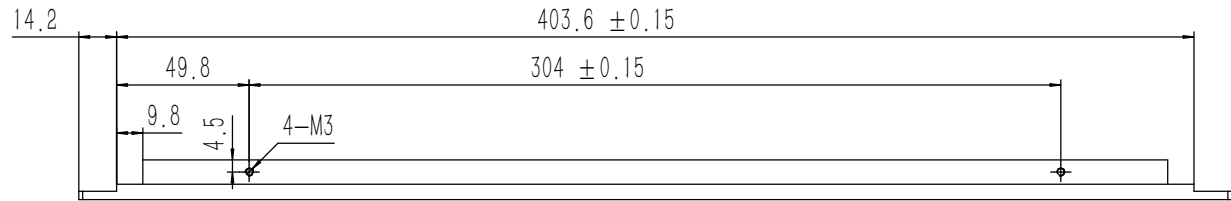
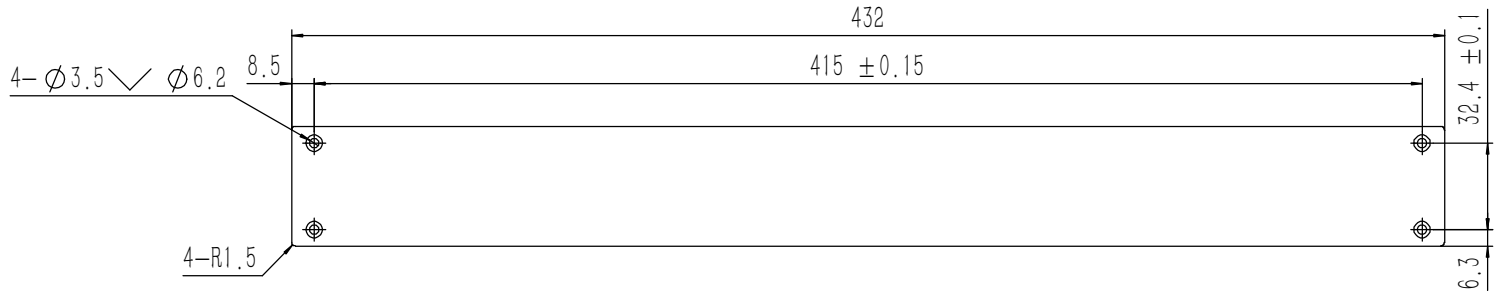
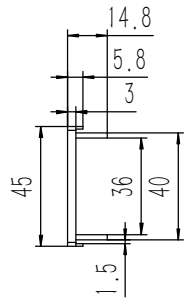

技术要求:

- 1、零件加工表面不应有划痕、擦伤等损伤零件表面的缺陷;
- 2、去除毛刺飞边, 锐角倒钝;
- 3、未标注尺寸见3D数模。

Tolerances (未注公差): 0.5 to 6 ± 0.1 6 to 30 ± 0.2 30 to 120 ± 0.3 120 to 400 ± 0.4	Material (材料):	6063-T5		YONGU 永固			
	Weight: (重量) (Kg):	0.212					
Break sharp edges (未注锐边倒角): Ch 0.05 to 0.25 x45°	Protection: (表面处理):			Drawing Number (图号): YG-C01A-0000-002			
	Position tolerances (未注位置公差): ± 0.05	Part Name (零/部件名称): 后面板					
Angular tolerances (未注角度公差): <6° ± 10' <30° ± 20' <120° ± 30' >120° ± 1°	Drawn by (绘图):	邓展锋	Date (日期):	2020.05.24	Size: (图幅):	A1	Sheet (页数): 1 / 1
	Signature by (批准):		Date (日期):		Scale (比例):	1:1	
	Check by (校对):		Date (日期):		Revision (版本):	A1	