

技术要求:

- 1、必须按照设计、工艺要求及本规定和有关标准进行装配;
- 2、所有零部件(包括外购、外协件)必须具有检验合格证方能进行装配;
- 3、零件在装配前必须清理和清洗干净,不得有毛刺、飞边、氧化皮、锈蚀、切屑、砂粒、灰尘和油污等,并应符合相应清洁度要求;
- 4、装配过程中零件不得磕碰、划伤和锈蚀;
- 5、油漆未干的零件不得进行装配;
- 6、相对运动的零件,装配时接触面间应加润滑油脂;
- 7、各零、部件装配后相对位置应准确。

7	GB-T-819.1-2000-C-BE-M3X8	碳钢发黑十字沉头螺 丝M3X8	普通碳钢	4	0.0005	
6	GB-T-819.1-2000-C-BE-M3X6	碳钢发黑十字沉头螺 丝M3X6	普通碳钢	8	0.0004	
5	GB-T-70.1-2000-S-NL-M3X8	不锈钢内六角杯头螺 丝M3X8	SUS 304	4	0.001	
4	YG-W27A-0000-004	后面板	6063-T5	1	0.377	
3	YG-W27A-0000-003	前面板	5052-H32	1	0.856	
2	YG-W27A-0000-002	盖板	5052-H32	2	0.774	
1	YG-W27A-0000-001	侧板	6063-T5	2	0.431	
序号	图号	名称	材料	数量	单重	备注

Tolerances (未注公差):		Material (材料): (装配图)		<b>YONGU</b> 永固	
0.5 to 6 ± 0.1		Weight: (重量) (Kg): 3.652			
6 to 30 ± 0.2		Protection: (表面处理):			
30 to 120 ± 0.3		Part Name (零/部件名称):			
120 to 400 ± 0.4		W27A功放		Drawing Number (图号): YG-W27A-0000-000	
Break sharp edges (未注锐边倒角): Ch 0.05 to 0.25 x45°	Angular tolerances (未注角度公差):	Drawn by (绘图): 邓展锋	Date (日期): 2020.05.16	Size (图幅): A0	 Sheet (页数): 1 / 1
Position tolerances (未注位置公差): ±0.05	<6° ± 10'	Check by (校对):	Date (日期):	Scale (比例): 1:1	
	<30° ± 20'	Signature by (批准):	Date (日期):	Revision (版本): A1	
	<120° ± 30'				
	>120° ± 1°				

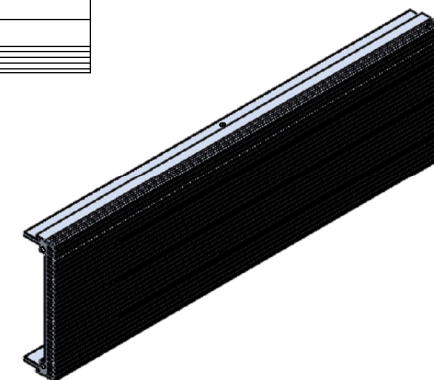
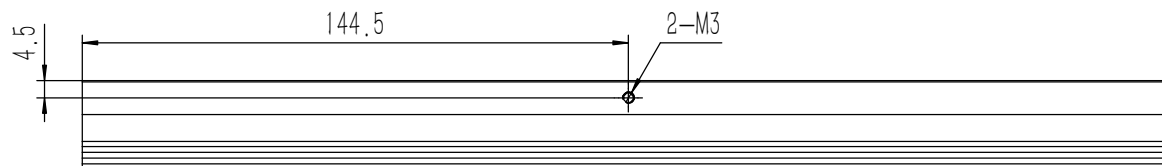
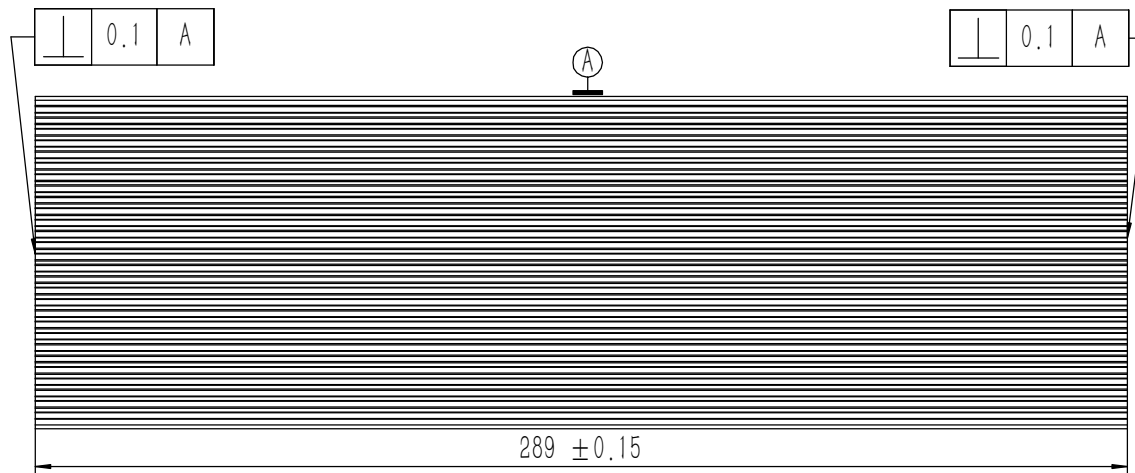
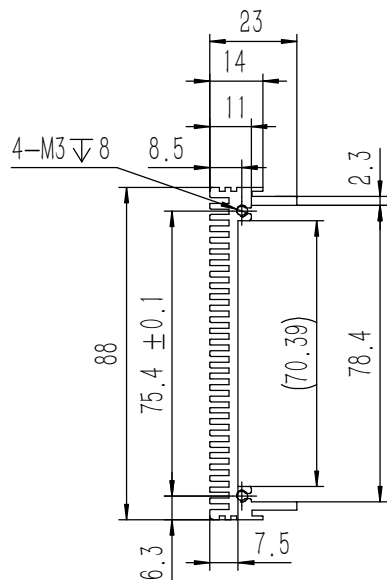

技术要求:

- 1、零件加工表面不应有划痕、擦伤等损伤零件表面的缺陷;
- 2、去除毛刺飞边,锐角倒钝;
- 3、未标注尺寸见3D数模。

Tolerances (未注公差): 0.5 to 6 ± 0.1 6 to 30 ± 0.2 30 to 120 ± 0.3 120 to 400 ± 0.4	Material (材料): 6063-T5 Weight: (重量) (Kg): 0.431 Protection: (表面处理): Part Name (零/部件名称):	YONGU 永固	
Break sharp edges (未注锐边倒角): Ch 0.05 to 0.25 x45°	Angular tolerances (未注角度公差): <6° ± 10' <30° ± 20' <120° ± 30' >120° ± 1°	侧板	
Position tolerances (未注位置公差): ±0.05	Drawn by (绘图): 邓展锋 Check by (校对): Signature by (批准):	Date (日期): 2020.05.16 Date (日期): Date (日期):	Size: (图幅): A2 Scale (比例): 1:1 Revision (版本): A1
			Sheet (页数): 1 / 1



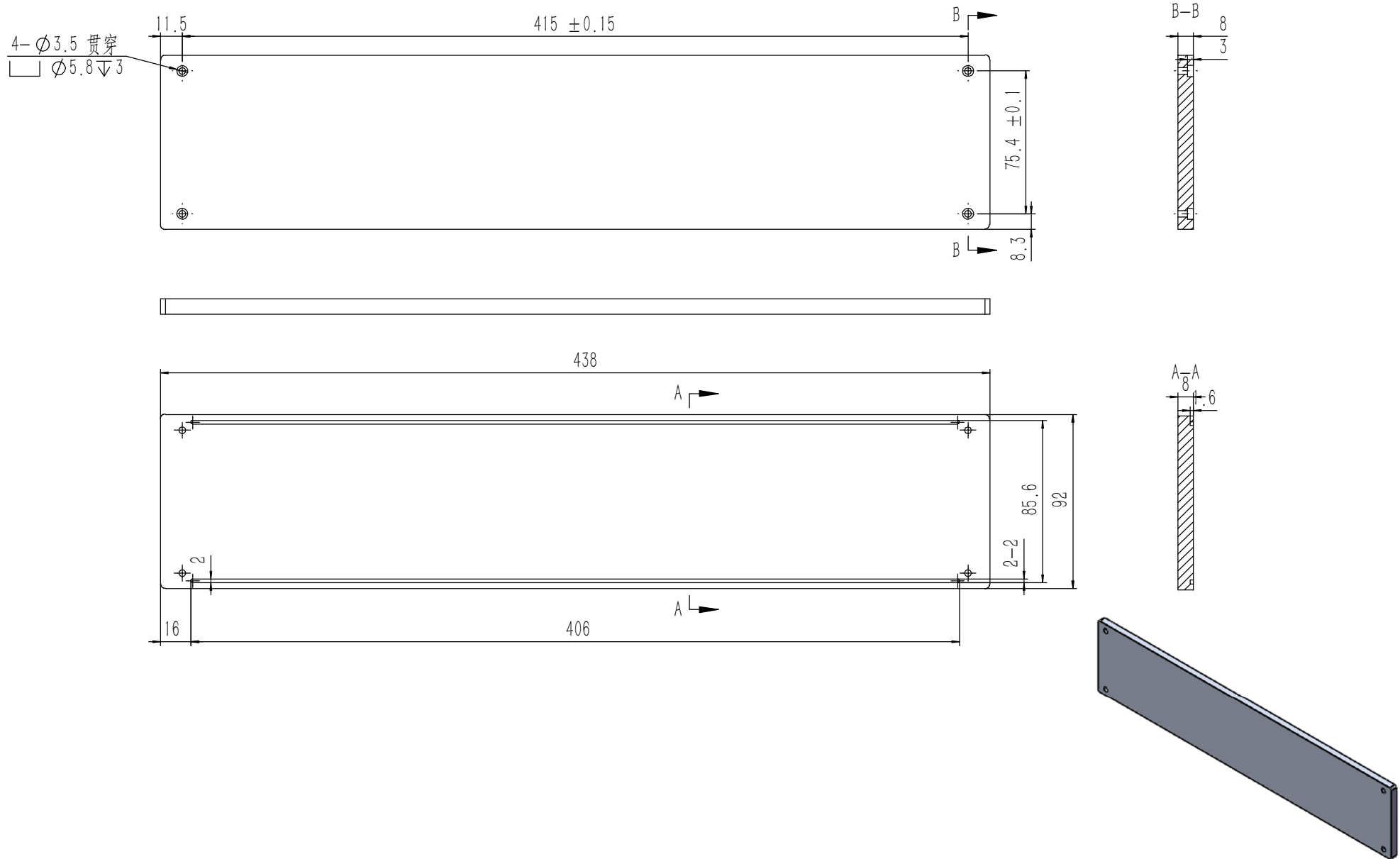

技术要求:

- 1、零件加工表面不应有划痕、擦伤等损伤零件表面的缺陷;
- 2、去除毛刺飞边,锐角倒钝;
- 3、未标注尺寸见3D数模。

Tolerances (未注公差): 0.5 to 6 ± 0.1 6 to 30 ± 0.2 30 to 120 ± 0.3 120 to 400 ± 0.4	Material (材料):	5052-H32	
	Weight: (重量) (Kg):	0.856	
Break sharp edges (未注锐边倒角): Ch 0.05 to 0.25 x45°	Protection: (表面处理):		
	Part Name (零/部件名称):	前面板	
Angular tolerances (未注角度公差): <6° ± 10' <30° ± 20' <120° ± 30' >120° ± 1°	Position tolerances (未注位置公差): ± 0.05	Drawing Number (图号):	YG-W27A-0000-003
	Drawn by (绘图): 邓展锋	Date (日期): 2020.05.16	Size: (图幅): A1
	Check by (校对):	Date (日期):	Scale (比例): 1:1
	Signature by (批准):	Date (日期):	Revision (版本): A1
			Sheet (页数): 1 / 1



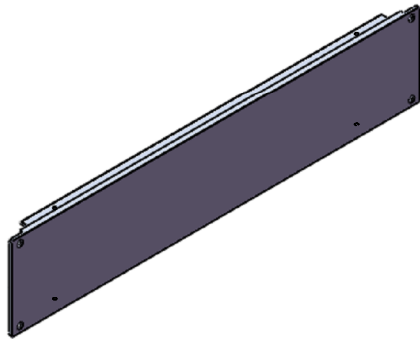
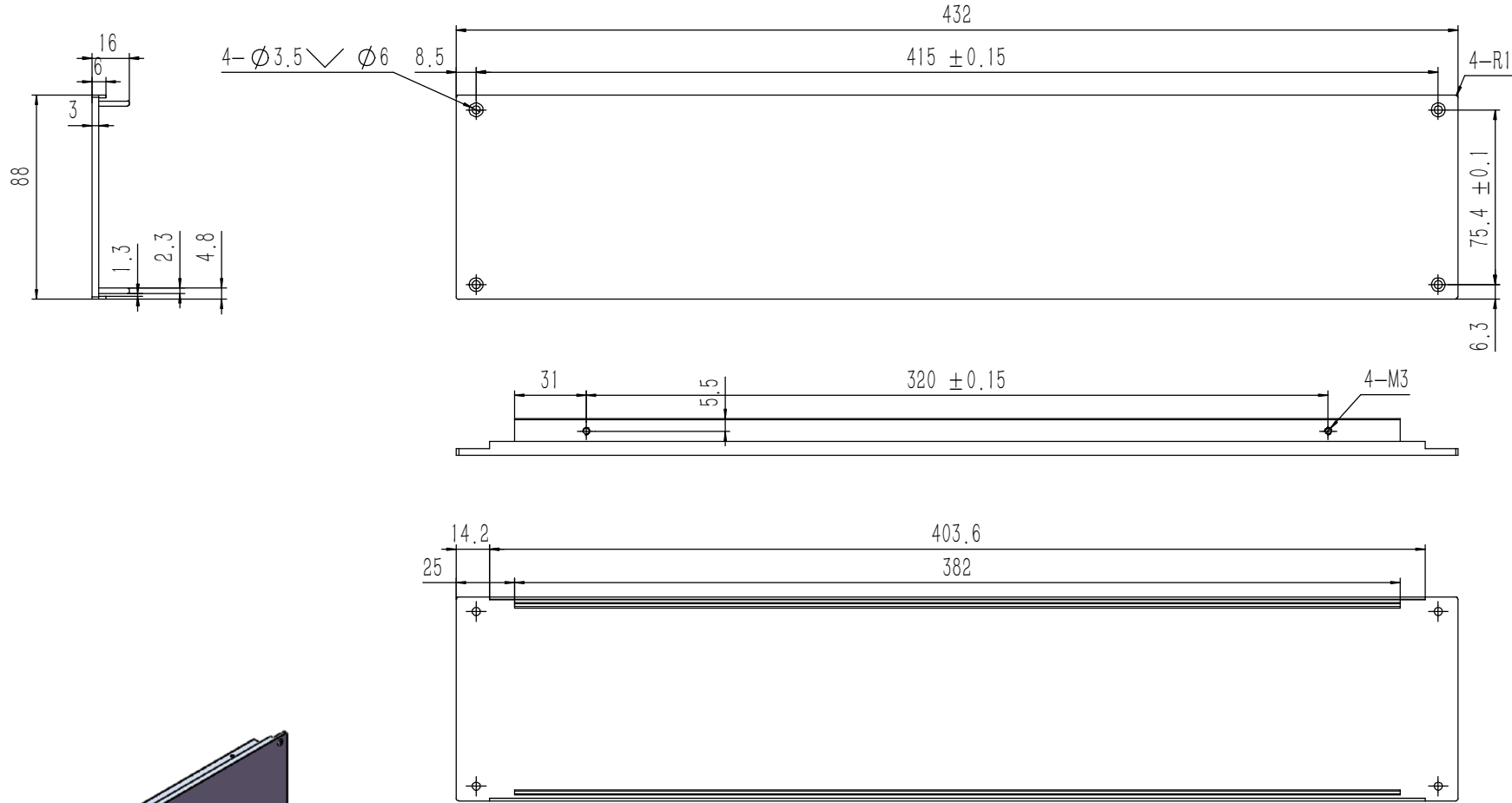

技术要求:

- 1、零件加工表面不应有划痕、擦伤等损伤零件表面的缺陷;
- 2、去除毛刺飞边,锐角倒钝;
- 3、未标注尺寸见3D数模。

Tolerances (未注公差): 0.5 to 6 ± 0.1 6 to 30 ± 0.2 30 to 120 ± 0.3 120 to 400 ± 0.4	Material (材料):	6063-T5		<b>YONGU</b> 永固
	Weight: (重量) (Kg):	0.377		
Break sharp edges (未注锐边倒角): Ch 0.05 to 0.25 x45°	Protection: (表面处理):			Drawing Number (图号): YG-W27A-0000-004
	Angular tolerances (未注角度公差): <6° ± 10' <30° ± 20' <120° ± 30' >120° ± 1°	Part Name (零/部件名称): 后面板		
Position tolerances (未注位置公差): ± 0.05	Drawn by (绘图): 邓展锋	Date (日期): 2020.05.16	Size: (图幅): A1	Sheet (页数): 1 / 1
	Check by (校对):	Date (日期):	Scale (比例): 1:1	
	Signature by (批准):	Date (日期):	Revision (版本): A1	