

技术要求:

- 1、必须按照设计、工艺要求及本规定和有关标准进行装配;
- 2、所有零部件(包括外购、外协件)必须具有检验合格证方能进行装配;
- 3、零件在装配前必须清理和清洗干净,不得有毛刺、飞边、氧化皮、锈蚀、切屑、砂粒、灰尘和油污等,并应符合相应清洁度要求;
- 4、装配过程中零件不得磕碰、划伤和锈蚀;
- 5、油漆未干的零件不得进行装配;
- 6、相对运动的零件,装配时接触面间应加润滑油脂;
- 7、各零、部件装配后相对位置应准确。

序号	图号	名称	材料	数量	单重	备注
3	GB-T-819.1-2000-C-NI-M2.5X6	碳钢镀镍十字沉头螺丝 M2.5X6	普通碳钢	8	0.0003	
2	YG-H08A-0000-002	挡板	5052-H32	2	0.0104	
1	YG-H08A-0000-001	壳体	6063-T5	2	0.0724	

Tolerances (未注公差): 0.5 to 6 ± 0.1 6 to 30 ± 0.2 30 to 120 ± 0.3 120 to 400 ± 0.4	Material (材料):	(装配图)	
	Weight: (重量) (Kg)	0.1677	
Break sharp edges (未注锐边倒角): Ch 0.05 to 0.25 x45°	Protection: (表面处理):		
	Part Name (零/部件名称):	H08A壳体	
Position tolerances (未注位置公差): ±0.05	Angular tolerances (未注角度公差): <6° ± 10' <30° ± 20' <120° ± 30' >120° ± 1°	Drawing Number (图号):	YG-H08A-0000-000
	Drawn by (绘图):	莫永康	Date (日期): 2020.05.11
Check by (校对):		Date (日期):	Scale (比例): 1:1
Signature by (批准):		Date (日期):	Revision (版本): A1
		Sheet (页数):	1 / 1



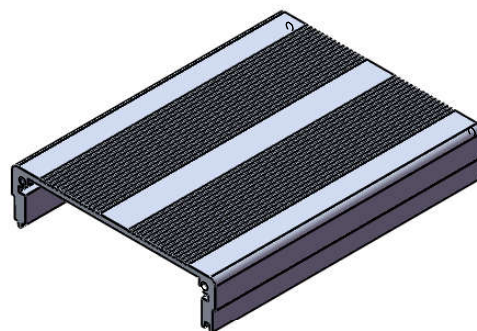
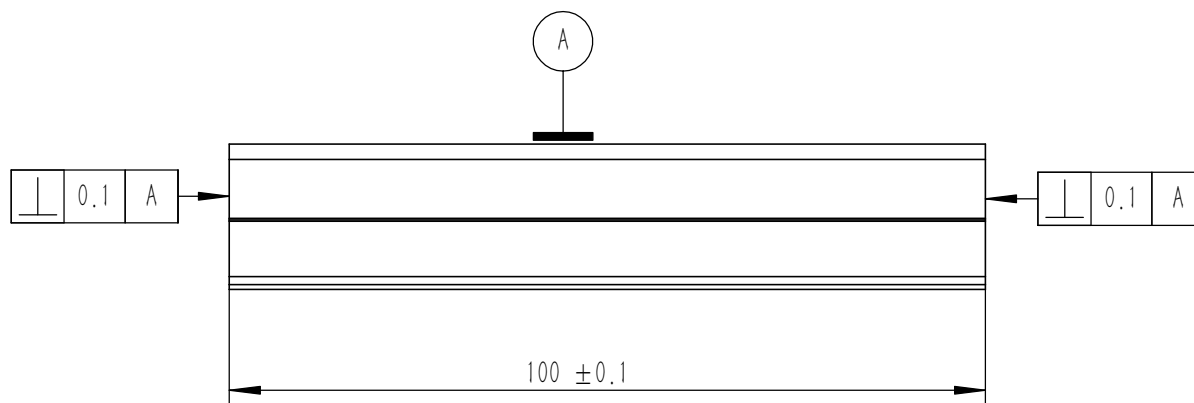
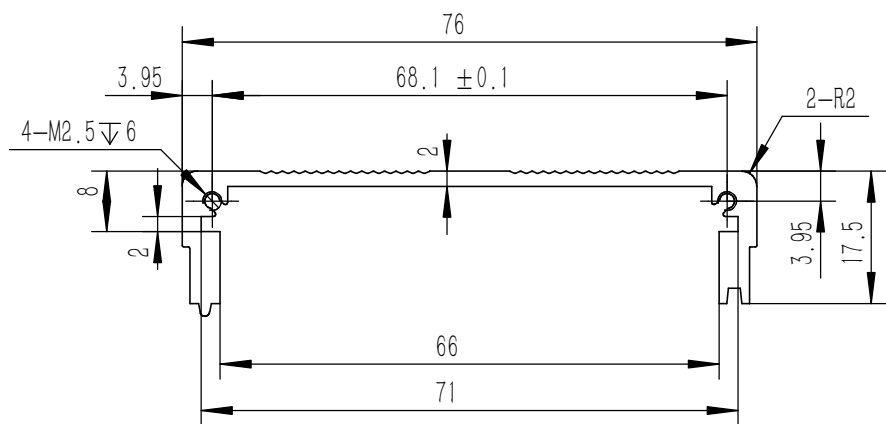

技术要求:

- 1、零件加工表面不应有划痕、擦伤等损伤零件表面的缺陷;
- 2、去除毛刺飞边, 锐角倒钝;
- 3、未标注尺寸见3D数模。

Tolerances (未注公差): 0.5 to 6 ± 0.1 6 to 30 ± 0.2 30 to 120 ± 0.3 120 to 400 ± 0.4	Material (材料):	6063-T5		YONGU 永固	
	Weight: (重量) (Kg)	0.072			
	Protection: (表面处理):			Drawing Number (图号): YG-H08A-0000-001	
	Part Name (零/部件名称):	壳体			
Break sharp edges (未注锐边倒角): Ch 0.05 to 0.25 x45°	Angular tolerances (未注角度公差): <6° ± 10' <30° ± 20' <120° ± 30' >120° ± 1°	Drawn by (绘图): 莫永康	Date (日期): 2020.05.11	Size: (图幅): A4	 Sheet (页数): 1 / 1
Position tolerances (未注位置公差): ±0.05	Check by (校对):	Date (日期):	Scale (比例): 1:1		
Signature by (批准):	Date (日期):	Revision (版本): A1	1 / 1		

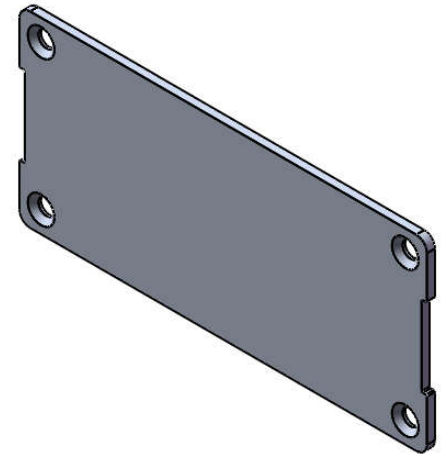
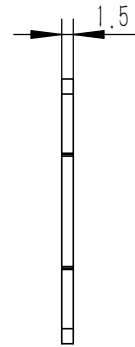
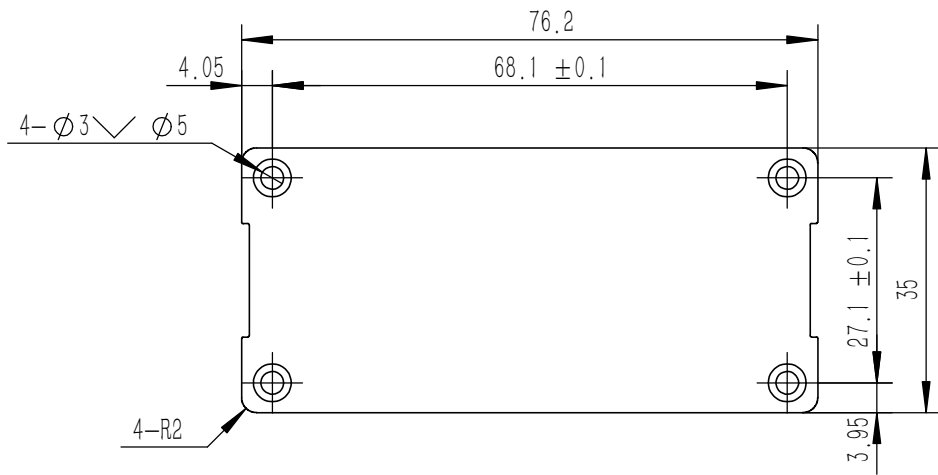

技术要求:

- 1、零件加工表面不应有划痕、擦伤等损伤零件表面的缺陷;
- 2、去除毛刺飞边,锐角倒钝;
- 3、未标注尺寸见3D数模。

Tolerances (未注公差): 0,5 to 6 ± 0,1 6 to 30 ± 0,2 30 to 120 ± 0,3 120 to 400 ± 0,4	Material (材料): 5052-H32	YONGU 永固	
	Weight: (重量) (Kg) 0.010		
Break sharp edges (未注锐边倒角): Ch 0,05 to 0,25 x45°	Protection: (表面处理):	Part Name (零/部件名称): 挡板	
	Position tolerances (未注位置公差): ±0,05	Part Name (零/部件名称): 挡板	Drawing Number (图号): YG-H08A-0000-002
Angular tolerances (未注角度公差): <6° ± 10' <30° ± 20' <120° ± 30' >120° ± 1°	Drawn by (绘图): 莫永康	Date (日期): 2020.05.11	Size: (图幅): A4
	Check by (校对):	Date (日期):	Scale (比例): 1:1
	Signature by (批准):	Date (日期):	Revision (版本): A1
			Sheet (页数): 1 / 1