

技术要求:

- 1、必须按照设计、工艺要求及本规定和有关标准进行装配;
- 2、所有零部件(包括外购、外协件)必须具有检验合格证方能进行装配;
- 3、零件在装配前必须清理和清洗干净,不得有毛刺、飞边、氧化皮、锈蚀、切屑、砂粒、灰尘和油污等,并应符合相应清洁度要求;
- 4、装配过程中零件不得磕碰、划伤和锈蚀;
- 5、油漆未干的零件不得进行装配;
- 6、相对运动的零件,装配时接触面间应加润滑油脂;
- 7、各零、部件装配后相对位置应准确。

序号	图号	名称	材料	数量	单重	备注
5	GB-T-819.1-2000-C-BE-M3X6	碳钢发黑十字沉头螺丝M3X6	普通碳钢	8	0.0004	
4	YG-G04C-0000-004	侧板	6063-T5	2	0.203	
3	YG-G04C-0000-003	底板	5052-H32	1	0.286	
2	YG-G04C-0000-002	上盖板	5052-H32	1	0.337	
1	YG-G04C-0000-001	前后面板	5052-H32	2	0.095	

Break sharp edges (未注锐边倒角): Ch 0.05 to 0.25 x45°	Angular tolerances (未注角度公差): <6° ± 10' <30° ± 20' <120° ± 30' >120° ± 1°
Position tolerances (未注位置公差): ± 0.05	

Tolerances (未注公差): 0.5 to 6 ± 0.1 6 to 30 ± 0.2 30 to 120 ± 0.3 120 to 400 ± 0.4	Material (材料): (装配图)
	Weight: (重量) (Kg): 1.222
	Protection: (表面处理):
	Part Name (零/部件名称): G04C机箱
Drawn by (绘图): 莫永康	Date (日期): 2020.05.28
Check by (校对):	Date (日期):
Signature by (批准):	Date (日期):

YONGU 永固	
Drawing Number (图号): YG-G04C-0000-000	
Size: (图幅): A1	☞ ⊕
Scale: (比例): 1:1	Sheet (页数):
Revision (版本): A1	1 / 1

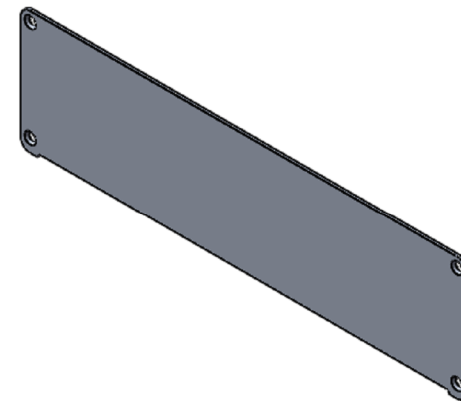
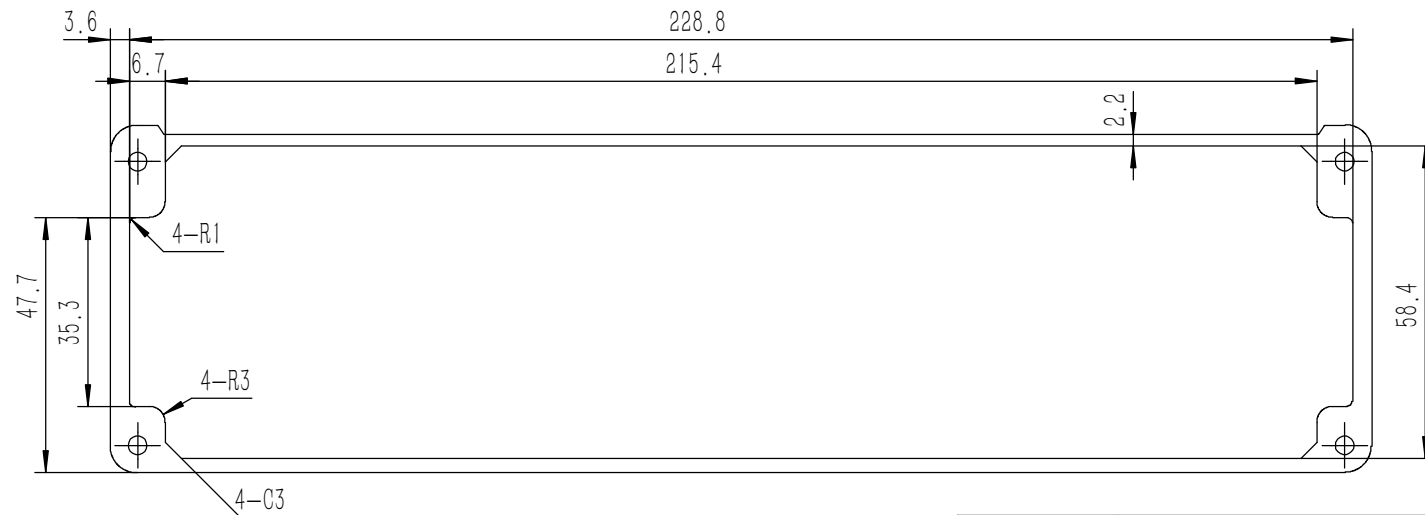
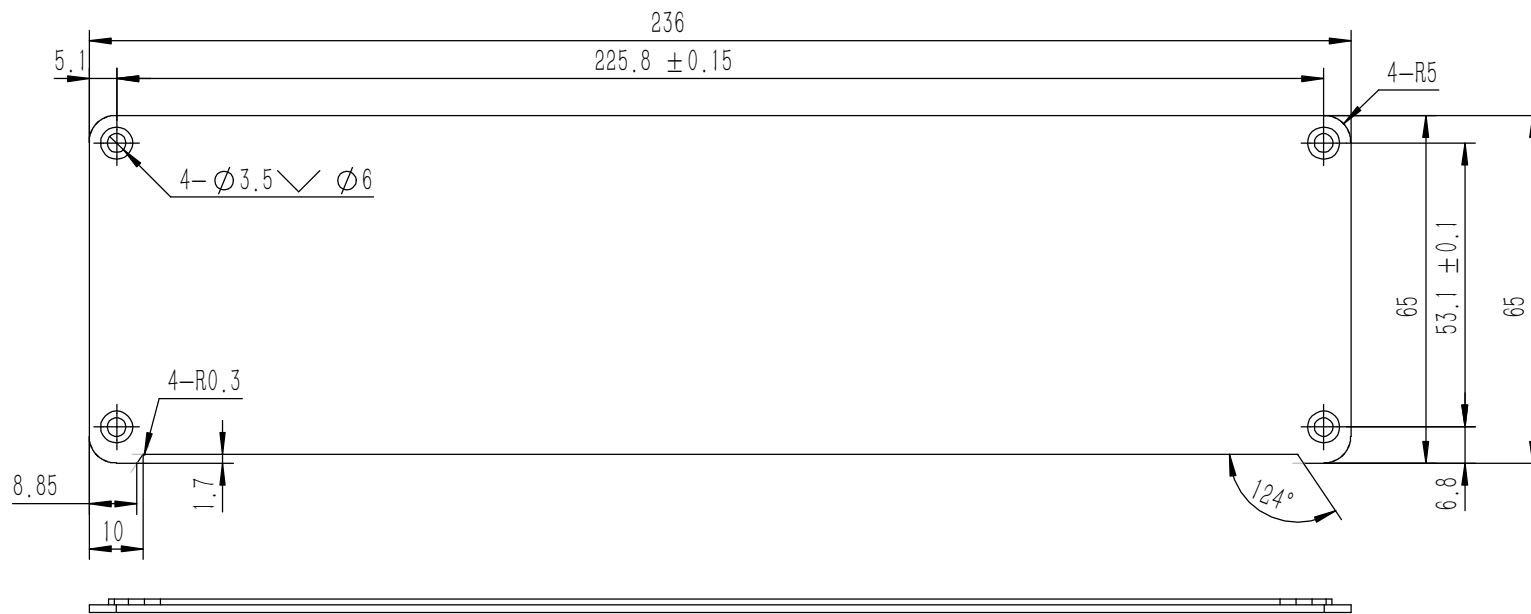

技术要求:

- 1、零件加工表面不应有划痕、擦伤等损伤零件表面的缺陷;
- 2、去除毛刺飞边, 锐角倒钝;
- 3、未标注尺寸见3D数模。

Tolerances (未注公差): 0.5 to 6 ± 0.1 6 to 30 ± 0.2 30 to 120 ± 0.3 120 to 400 ± 0.4	Material (材料):	5052-H32		YONGU 永固
	Weight: (重量) (Kg)	0.095		
Break sharp edges (未注锐边倒角): Ch 0.05 to 0.25 x45°	Protection: (表面处理):			Drawing Number (图号): YG-G04C-0000-001
	Position tolerances (未注位置公差): ±0.05	Part Name (零/部件名称):	前后面板	
Angular tolerances (未注角度公差): <6° ± 10' <30° ± 20' <120° ± 30' >120° ± 1°	Drawn by (绘图):	莫永康	Date (日期):	2020.05.27
	Signature by (批准):		Date (日期):	
	Check by (校对):		Date (日期):	
	Signature by (批准):		Date (日期):	
	Scale (比例):	1:1		Sheet (页数): 1 / 1
	Revision (版本):	A1		

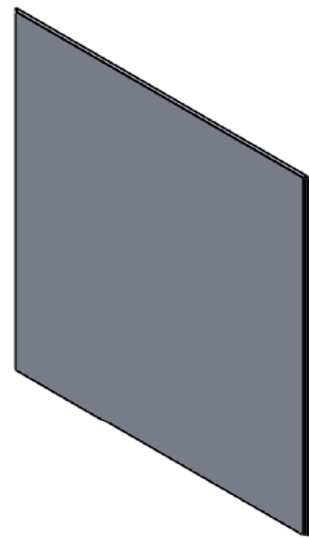
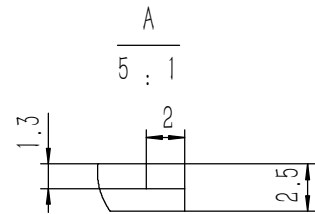
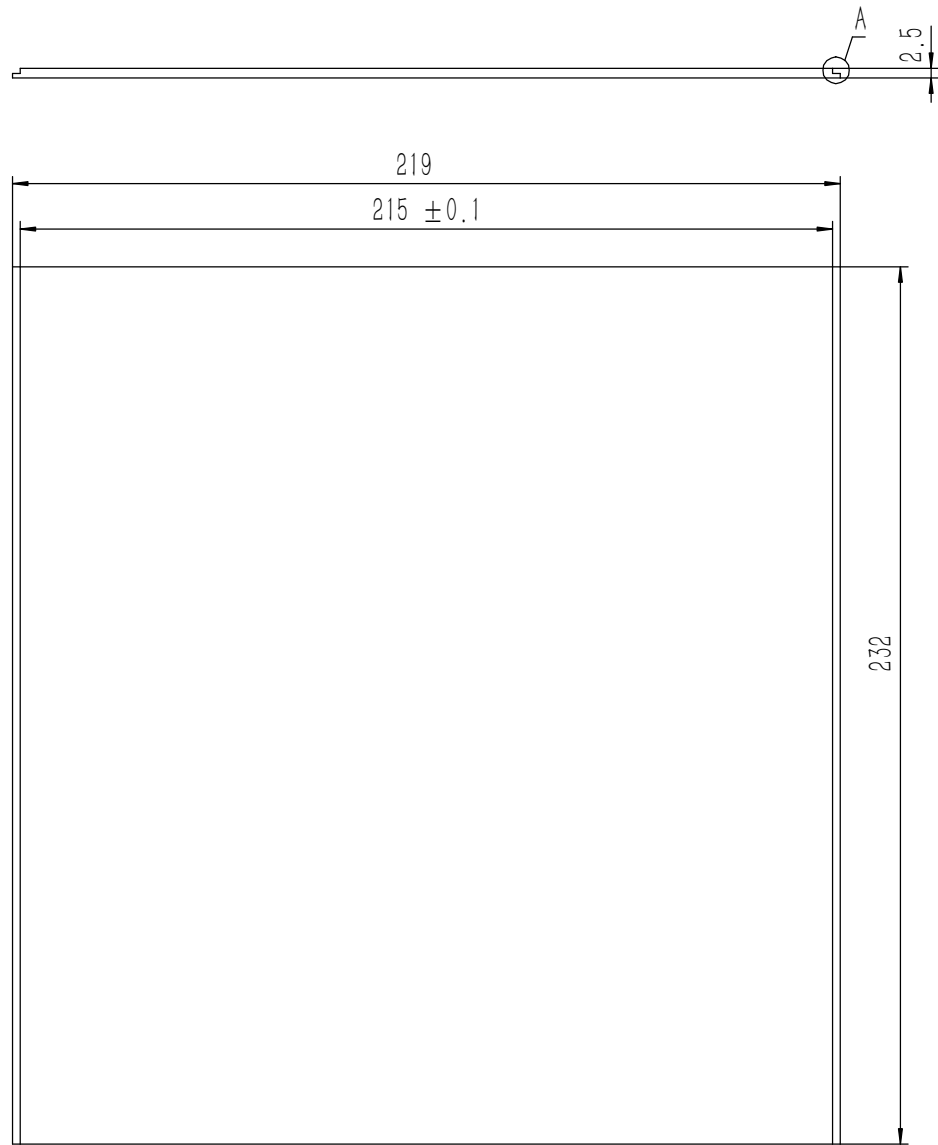

技术要求:

- 1、零件加工表面不应有划痕、擦伤等损伤零件表面的缺陷;
- 2、去除毛刺飞边,锐角倒钝;
- 3、未标注尺寸见3D数模。

Tolerances (未注公差): 0.5 to 6 ± 0.1 6 to 30 ± 0.2 30 to 120 ± 0.3 120 to 400 ± 0.4	Material (材料):	5052-H32		YONGU 永固				
	Weight: (重量) (Kg):	0.337						
Break sharp edges (未注锐边倒角): Ch 0.05 to 0.25 x45°	Protection: (表面处理):			Drawing Number (图号): YG-G04C-0000-002				
	Part Name (零/部件名称):	上盖板						
Position tolerances (未注位置公差): ±0.05	Angular tolerances (未注角度公差): <6° ± 10' <30° ± 20' <120° ± 30' >120° ± 1°	Drawn by (绘图):	莫永康	Date (日期):	2020.05.27	Size: (图幅):	A2	Sheet (页数): 1 / 1
		Check by (校对):		Date (日期):		Scale (比例):	1:1	
		Signature by (批准):		Date (日期):		Revision (版本):	A1	

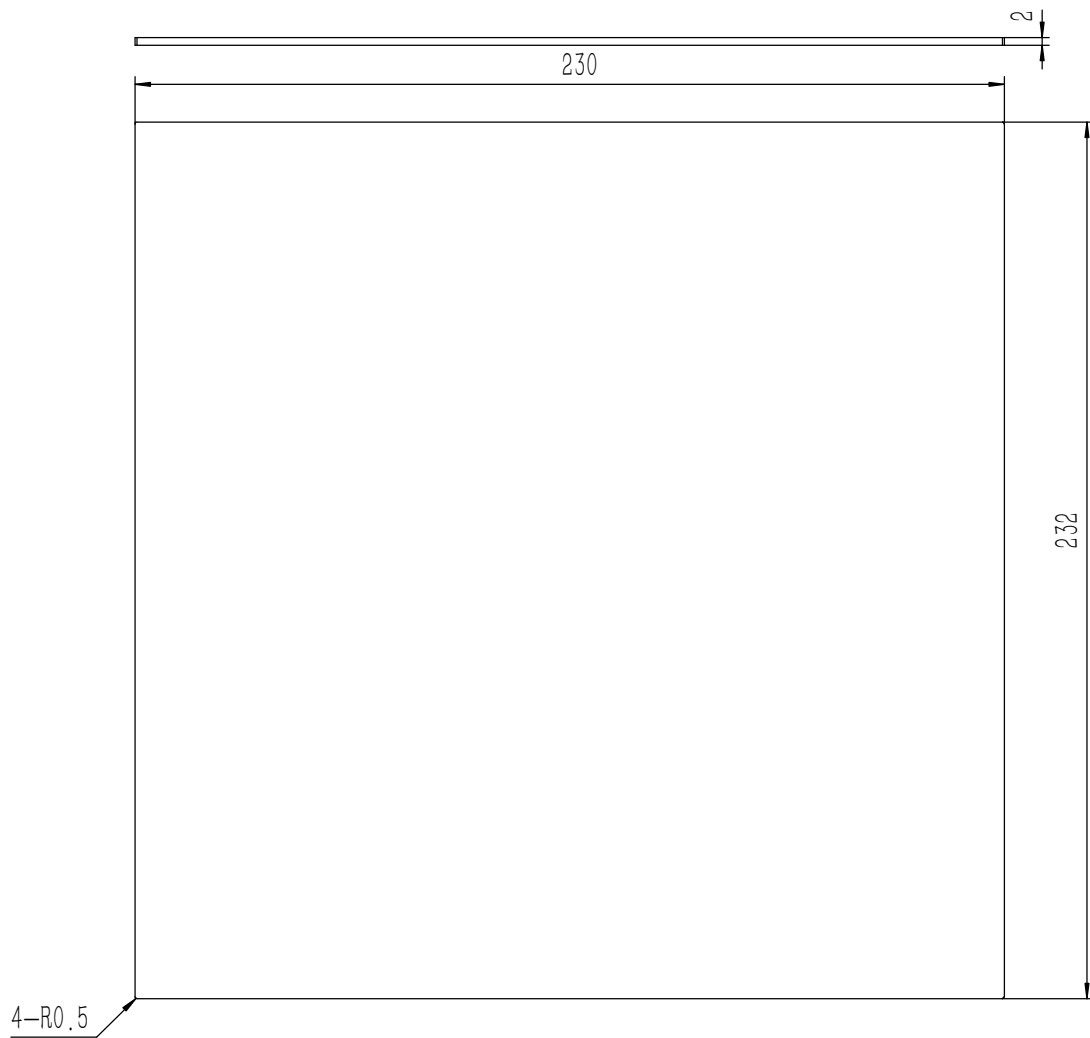

4-R0.5

230

2

232

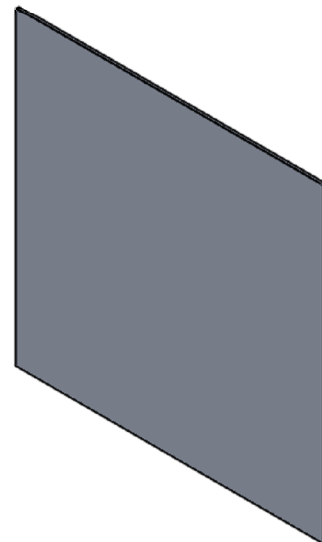

技术要求:

- 1、零件加工表面不应有划痕、擦伤等损伤零件表面的缺陷;
- 2、去除毛刺飞边, 锐角倒钝;
- 3、未标注尺寸见3D数模。

Tolerances (未注公差):		Material (材料):	5052-H32					
0.5 to 6	± 0.1	Weight: (重量) (Kg):	0.286					
6 to 30	± 0.2	Protection: (表面处理):						
30 to 120	± 0.3	Part Name (零/部件名称):	底板		Drawing Number (图号):			
120 to 400	± 0.4				YG-G04C-0000-003			
Break sharp edges (未注锐边倒角): Ch 0.05 to 0.25 x45°	Angular tolerances (未注角度公差):	Drawn by (绘图):	莫永康	Date (日期):	2020.05.27	Size: (图幅):	A2	
Position tolerances (未注位置公差):	<30° ± 20'	Check by (校对):		Date (日期):		Scale (比例):	1:1	
±0.05	<120° ± 30'	Signature by (批准):		Date (日期):		Revision (版本):	A1	
	>120° ± 1°							Sheet (页数):
								1 / 1

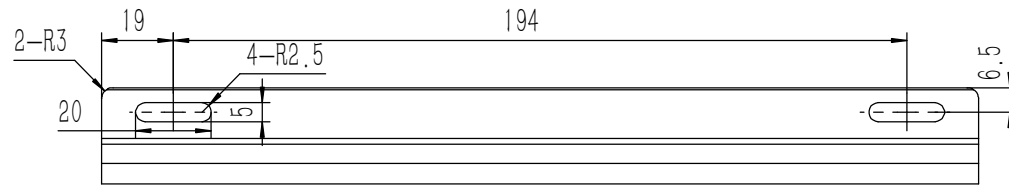
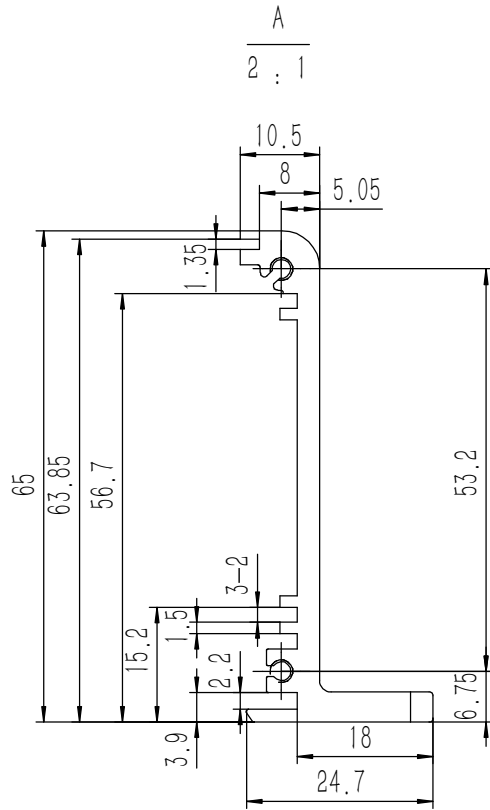
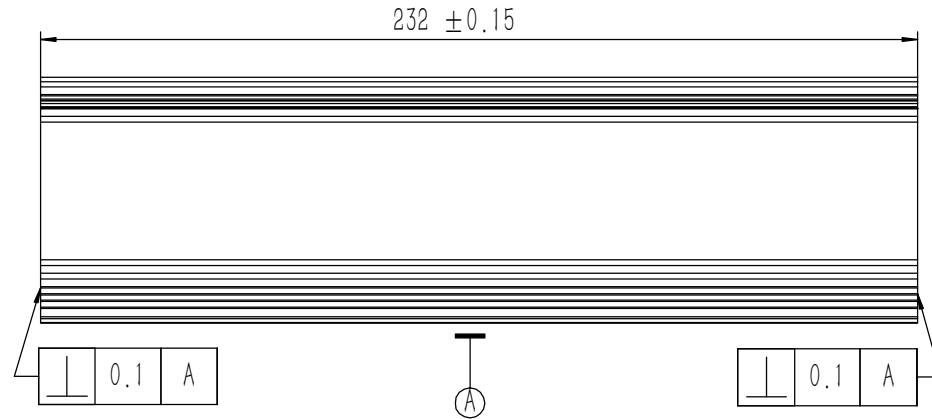
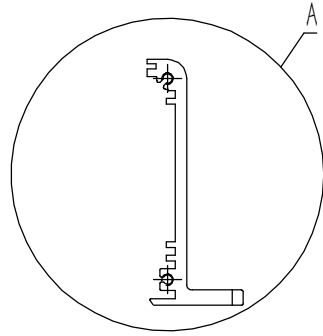

技术要求:

- 1、零件加工表面不应有划痕、擦伤等损伤零件表面的缺陷;
- 2、去除毛刺飞边,锐角倒钝;
- 3、未标注尺寸见3D数模。

Tolerances (未注公差): 0.5 to 6 ± 0.1 6 to 30 ± 0.2 30 to 120 ± 0.3 120 to 400 ± 0.4		Material (材料): 6063-T5 Weight: (重量) (Kg): 0.203 Protection: (表面处理): Part Name (零/部件名称):		YONGU 永固	
Break sharp edges (未注锐边倒角): Ch 0.05 to 0.25 x45°		Angular tolerances (未注角度公差): <6° ± 10' <30° ± 20' <120° ± 30' >120° ± 1°		Drawing Number (图号): YG-G04C-0000-004	
Position tolerances (未注位置公差): ±0.05		Part Name (零/部件名称): 侧板		Size (图幅): A2 Scale (比例): 1:1 Revision (版本): A1	
Drawn by (绘图): 莫永康		Date (日期): 2020.05.27		Sheet (页数): 1 / 1	
Check by (校对):		Date (日期):		Revision (版本): A1	
Signature by (批准):		Date (日期):		Revision (版本): A1	