

4	GB-T-70.1-2000-S-NL-M3X8	不锈钢内六角杯头螺丝M3X8	SUS 304	8	0.001	
3	YG-K16C01-0000-002	K16C红色塑料端盖	ABS	2	0.017	
2	YG-K16C-0000-003	挡板	5052-H32	2	0.021	
1	YG-K16C-0000-001	壳体	6063-T5	2	0.068	
序号 (Item)	图号 (Drawing Number)	名称 (Part Name)	材料 (Material)	数量 (QTY)	单重 (Weight)	备注 (Note)

Tolerances (未注公差):		Material (材料): (装配图)		YONGU	
0.5 to 6 ± 0.1	6 to 30 ± 0.2	Weight: (重量) (Kg): 0.220			
30 to 120 ± 0.3	120 to 400 ± 0.4	Protection: (表面处理):		Drawing Number (图号):	
Break sharp edges (未注锐边倒角): Ch 0.05 to 0.25 x45°		Part Name (零/部件名称):		YG-K16C-0000-000	
Position tolerances (未注位置公差): ±0.05		Angular tolerances (未注角度公差):		K16C壳体	
<6° ± 10'		<30° ± 20'		Drawn by (绘图): 江瑞章	Date (日期): 2020.12.14
<120° ± 30'		>120° ± 1°		Check by (校对):	Date (日期):
				Signature by (批准):	Date (日期):
				Size (图幅): A2	Scale (比例): 1:1
				Revision (版本): A1	Sheet (页数): 1 / 1

技术要求:

- 1、必须按照设计、工艺要求及本规定和有关标准进行装配;
- 2、所有零部件(包括外购、外协件)必须具有检验合格证方能进行装配;
- 3、零件在装配前必须清理和清洗干净,不得有毛刺、飞边、氧化皮、锈蚀、切屑、砂粒、灰尘和油污等,并应符合相应清洁度要求;
- 4、装配过程中零件不得磕碰、划伤和锈蚀;
- 5、油漆未干的零件不得进行装配;
- 6、相对运动的零件,装配时接触面间应加润滑油脂;
- 7、各零、部件装配后相对位置应准确。

业务代码:

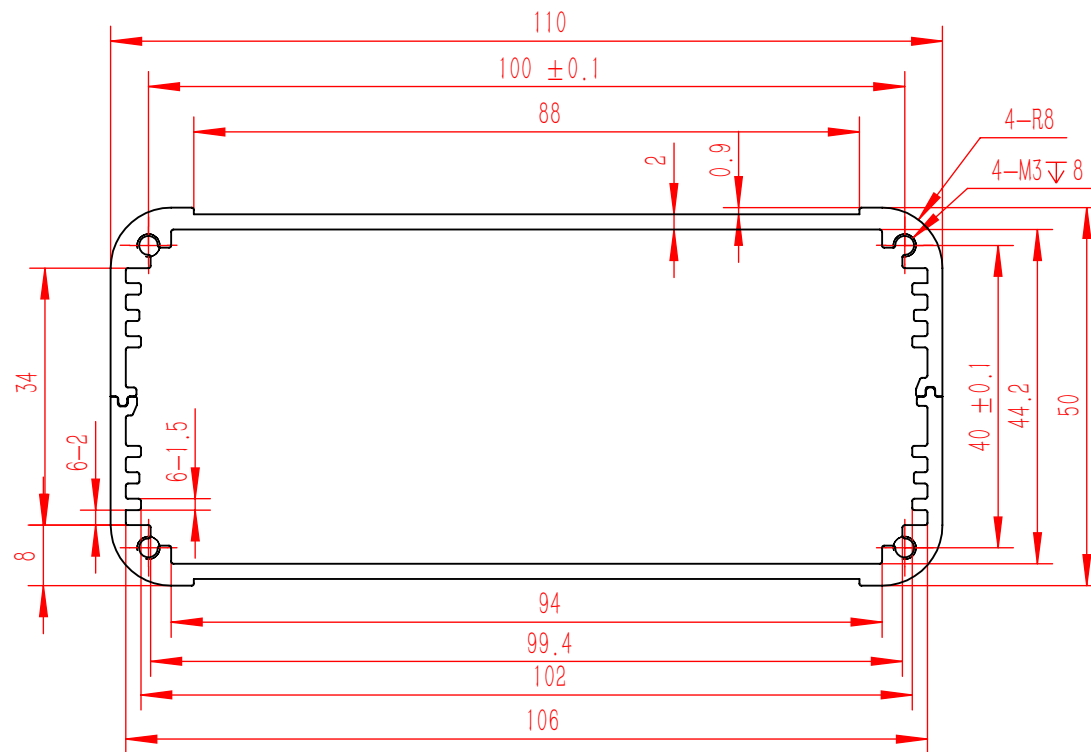

Tolerances (未注公差): 0.5 to 6 ± 0.1 6 to 30 ± 0.2 30 to 120 ± 0.3 120 to 400 ± 0.4	Material (材料): (装配图)	YONGU 	
	Weight: (重量) (Kg) 0.253		
Break sharp edges (未注锐边倒角): Ch 0.05 to 0.25 x45°	Part Name (零/部件名称): YG-K16截面图		Drawing Number (图号): YG-K16-JMT
	Position tolerances (未注位置公差): ±0.05	Angular tolerances (未注角度公差): <6° ± 10' <30° ± 20' <120° ± 30' >120° ± 1°	Drawn by (绘图): 江瑞章 Date (日期): 2020.12.14
	Check by (校对): Signature by (批准):	Date (日期): Date (日期):	Sheet (页数): 1 / 1

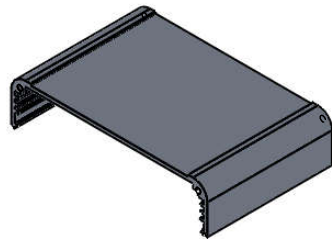
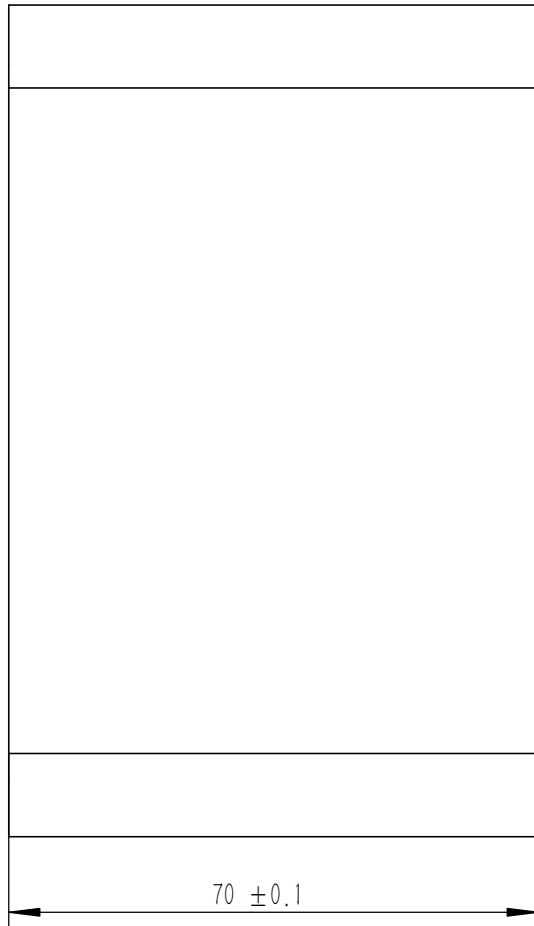

技术要求:

- 1、零件加工表面不应有划痕、擦伤等损伤零件表面的缺陷;
- 2、去除毛刺飞边,锐角倒钝;
- 3、未标注尺寸见3D数模。

业务代码:

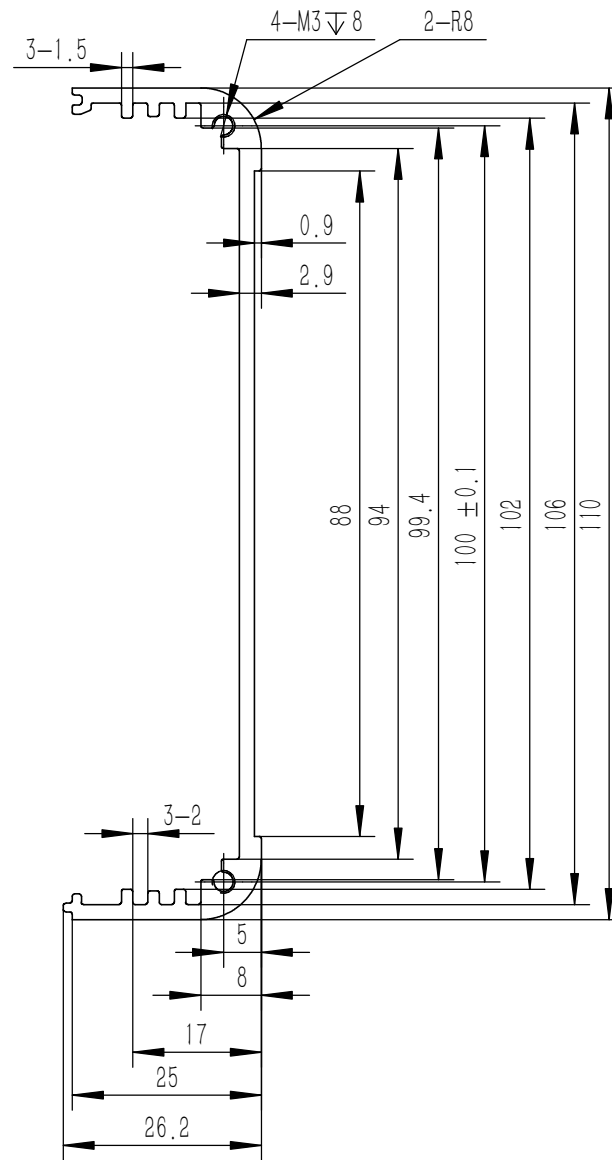

Tolerances (未注公差): 0.5 to 6 ± 0.1 6 to 30 ± 0.2 30 to 120 ± 0.3 120 to 400 ± 0.4	Material (材料): 6063-T5	YONGU 永固	
	Weight: (重量) (Kg) 0.068		
Break sharp edges (未注锐边倒角): Ch 0.05 to 0.25 x45°	Protection: (表面处理):	Part Name (零/部件名称):	
	Position tolerances (未注位置公差): ± 0.05	壳 体	
Angular tolerances (未注角度公差): <6° ± 10' <30° ± 20' <120° ± 30' >120° ± 1°	Part Name (零/部件名称):	Drawing Number (图号):	
	Drawn by (绘图): 江瑞章	Date (日期): 2020.12.14	YG-K16C-0000-001
Position tolerances (未注位置公差): ± 0.05	Check by (校对):	Date (日期):	Scale (比例): 1:1
	Signature by (批准):	Date (日期):	Revision (版本): A1
		Sheet (页数):	1 / 1

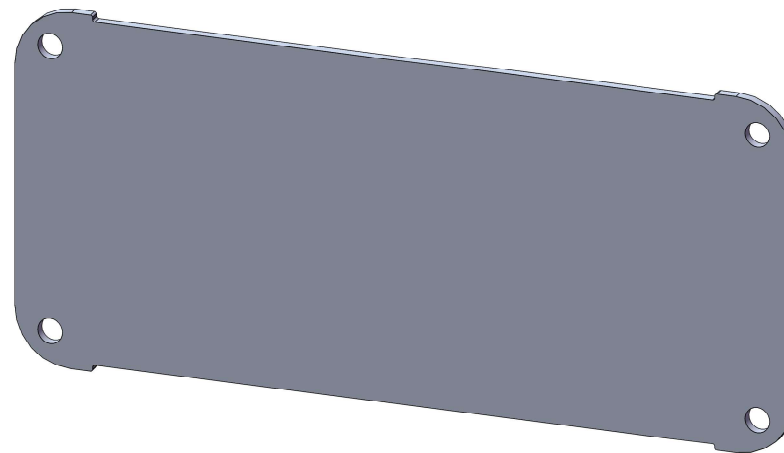
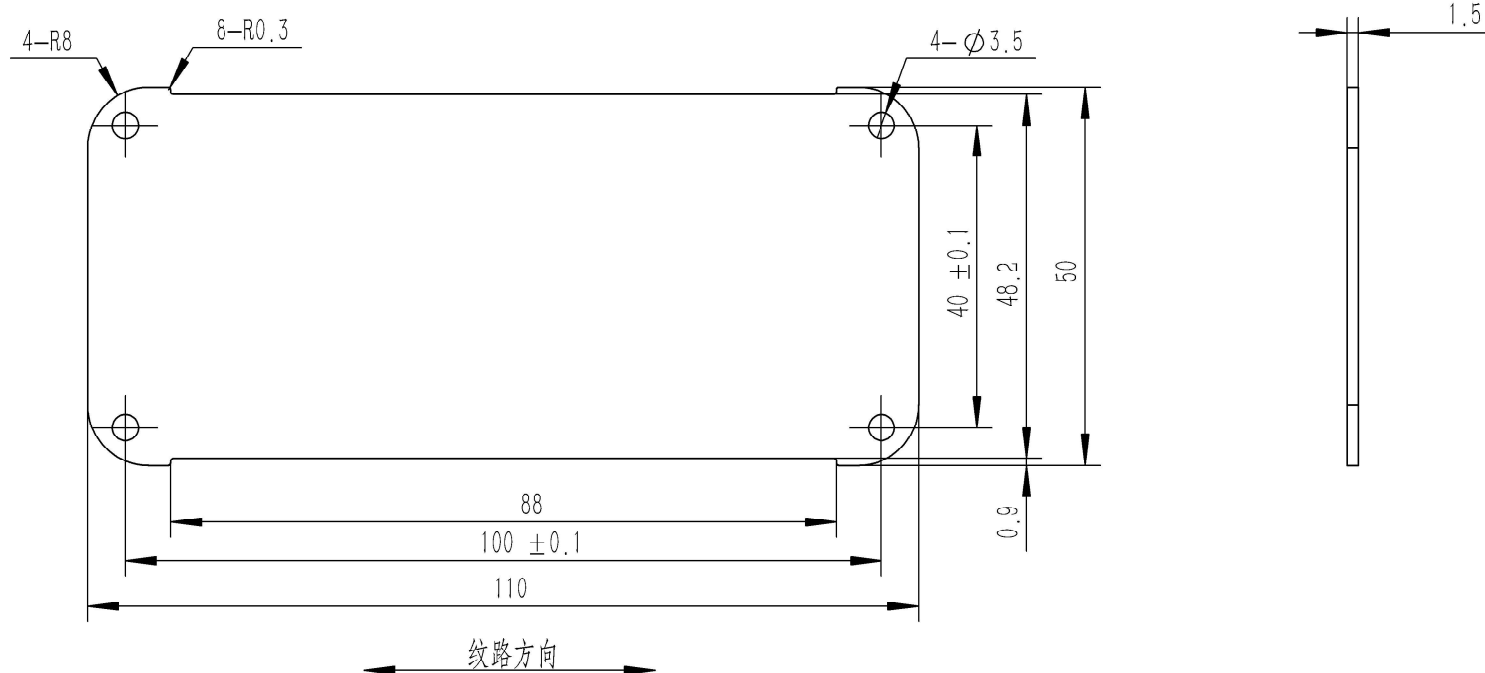

技术要求:

- 1、零件加工表面不应有划痕、擦伤等损伤零件表面的缺陷;
- 2、去除毛刺飞边, 锐角倒钝;
- 3、未标注尺寸见3D数模。

业务代码:

Tolerances (未注公差): 0.5 to 6 ± 0.1 6 to 30 ± 0.2 30 to 120 ± 0.3 120 to 400 ± 0.4	Material (材料):	5052-H32		YONGU 永固
	Weight: (重量) (Kg)	0.021		
Break sharp edges (未注锐边倒角): Ch 0.05 to 0.25 x45°	Protection: (表面处理):			
	Position tolerances (未注位置公差): ±0.05	Part Name (零/部件名称):	挡板	
Angular tolerances (未注角度公差): <6° ± 10' <30° ± 20' <120° ± 30' >120° ± 1°	Part Name (零/部件名称):	挡板		Drawing Number (图号):
	Position tolerances (未注位置公差): ±0.05	Part Name (零/部件名称):	挡板	
Position tolerances (未注位置公差): ±0.05	Drawn by (绘图):	江瑞章	Date (日期):	2020.12.14
	Position tolerances (未注位置公差): ±0.05	Check by (校对):	Date (日期):	
Position tolerances (未注位置公差): ±0.05	Signature by (批准):	Date (日期):	Scale (比例):	1:1
Position tolerances (未注位置公差): ±0.05	Signature by (批准):	Date (日期):	Revision (版本):	A1
Position tolerances (未注位置公差): ±0.05	Signature by (批准):	Date (日期):	Sheet (页数):	1 / 1

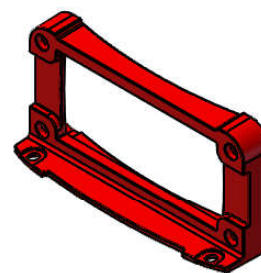
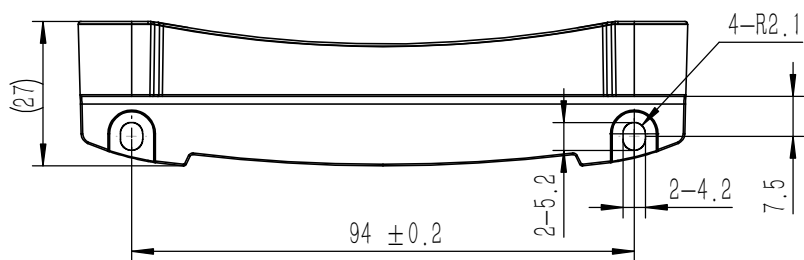
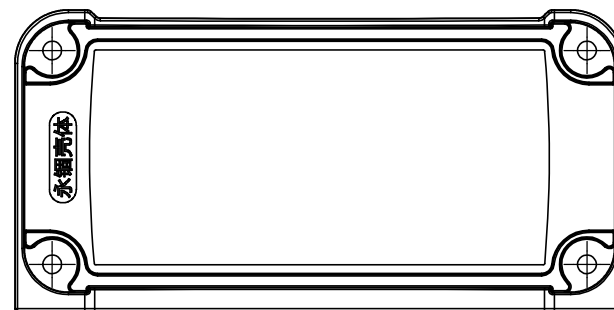
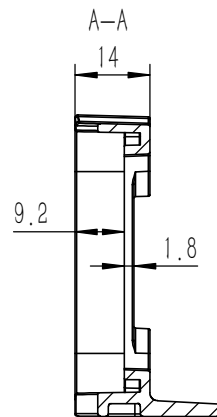
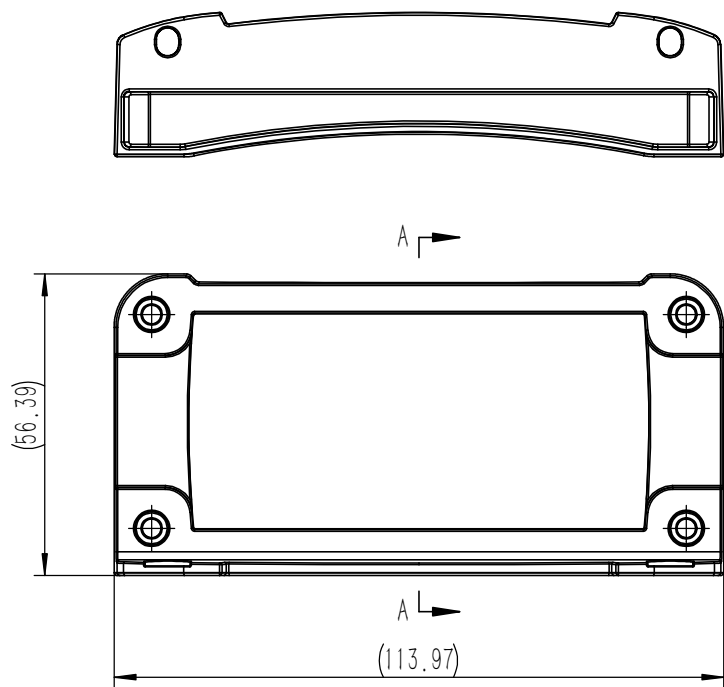

技术要求:

- 1、零件表面不允许有收缩、凹陷、熔接痕、水纹、顶白及飞边等缺陷
- 2、未标注尺寸见3D数模。

业务代码:

Break sharp edges (未注锐边倒角): Ch 0.05 to 0.25 x45°	Angular tolerances (未注角度公差): <6° ± 10' <30° ± 20' <120° ± 30' >120° ± 1°
Position tolerances (未注位置公差): ±0.05	

Tolerances (未注公差): 0.5 to 6 ± 0.1 6 to 30 ± 0.2 30 to 120 ± 0.3 120 to 400 ± 0.4	Material (材料): ABS	YONGU 永固
Weight: (重量) (Kg) 0.017	Protection: (表面处理): 喷橡胶漆	
Part Name (零/部件名称): K16C红色塑料端盖	Part Name (零/部件名称): K16C红色塑料端盖	Drawing Number (图号): YG-K16C01-0000-002
Drawn by (绘图): 江瑞章	Date (日期): 2020.12.14	Size (图幅): A3
Check by (校对):	Date (日期):	Scale (比例): 1:1
Signature by (批准):	Date (日期):	Revision (版本): A1
		Sheet (页数): 1 / 1