

ELECTRIC HOIST

MDH型环链电动葫芦

MDH Electric Chain hoist

MDH环链电动葫芦是经过精心设计的一款环链电动葫芦。此机结构简单、安装方便，且用单相电作为动力源。

适用范围：

广泛应用于机械、电子、汽车、造船、工件总装以及零配件生产的生产线、流水线、装配车间，还用于物流输送等场合。对在仓库、码头、配料、吊篮和空间较窄小的工作场地作业，更能显示出其优势。MDH环链电动葫芦是定柱式、墙壁式旋臂起重机的最佳配套产品，能够在工字钢上来回运行自如。

MDH环链电动葫芦特点：

- 1、电机精巧，效率高。采用直流电制动系统，有效降低电耗量。
- 2、机身是冲压钢结构，具有强度高、耐磨性好的优点。
- 3、具有伸展性强的安全钩，钩子顶部和底部都采用高强度的合金钢制成，经过特殊热处理，不易损坏，在额外的压力作用下不易变形。
- 4、高强度的外壳，经久耐用。
- 5、本机顶部和底部都安装了开关，关掉电源时可自动防止链条脱钩。
- 6、特制的逆向保护装置，防止电机在错误的轨道上行走。

1.Compact and high efficient motor

Dc brake system without asbestos, consumption of electricity reduced efficiently.

1)Hoist body

Pressing steel structure, high strength body, light and compact.

2)Most tensile safety hooks

Both the top and bottom hook made of high tensile alloy steel, with special treatment, it guarantee the hook will not break, and will deform gradually under a sudden extra-load.

3)Compact and beauty chain container

High strength plastic container have outstanding durability.

4)Limit switch devices

Fitted at both top and bottom ends, switch off power automatically to prevent load chain from running out.

5)Phase error relay

A specially designed current-post, prevents motor from running at incorrect wire connection.

Model: MDH

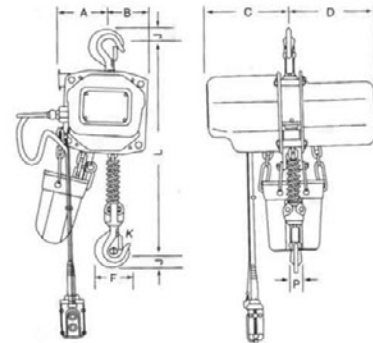

MDH型环链电动葫芦参数：

SPFCIFICATION

| 型号 Product Code | MDH-0.5A | MDH-1A | MDH-2A | MDH-3A |
|---------------------------------------|----------|--------|--------|--------|
| 额定起重量 Capacity(t) | 0.5 | 1.0 | 2.0 | 3.0 |
| 起升高度 Lifting height(m) | 3 | 3 | 3 | 3 |
| 试验载荷 Running Testload(kn) | 6.3 | 12.5 | 25 | 37.5 |
| 电机功率 Motor power(kw) | 0.8 | 1.1 | 1.1 | 1.1 |
| 起重链条行数 No.of columns of load chain | 1 | 1 | 2 | 3 |
| 起重链条直径 Load chain diameter(mm) | 7.1 | 7.1 | 7.1 | 7.1 |
| 起升速度 Rising speed(m/min) | 5.80 | 4.30 | 2.15 | 1.43 |
| 主要尺寸 Dimensions(mm) | A | 150 | 150 | 175 |
| | B | 112 | 112 | 90 |
| | C | 250 | 250 | 250 |
| | D | 245 | 245 | 245 |
| | K | 27 | 30 | 38 |
| | Φ | 45 | 50 | 65 |
| | F | 85 | 105 | 136 |
| | J | 17 | 26 | 36 |
| P | 14 | 15 | 22 | |
| L | 550 | 590 | 770 | 775 |
| 净重 Net weight(kg) | 44 | 46 | 60 | 68 |