

# CLAMP SERIES

## SDC型竖吊钢板起重钳

### SV PLUS VERTICAL LIFTING CLAMP

Model: SDC

**用途：**钢板的竖直吊运。

**载荷范围：**0~30吨

**特点：**1、采用低碳优质合金钢制造。

2、以单只试验为额定载荷，最大工作载荷为2倍，吊装作业中单只或二只配套使用。

3、只能同时吊运一块钢板，禁止层叠吊运，吊运过程中不得碰撞被吊物。起吊时，必须将拉环手柄向上以使弹簧拉紧；卸荷时，将锁紧手柄向下，弹簧放松后，钳和钢板才能分离。

#### Applications

Standard **SCD** clamp is design for vertical lifting and turning over of plates, the clamp possesses a safety device by which the lock is not disengaged even if the lifting rope is slackened. This clamp can be applied for a wide range of works which maintains a structure for safety against ground-touching shocks of the loads.

#### Technical Specialities

##### Benefits

1. Long product life
2. Meets standard BS EN13155
3. Guaranteed performance
4. Embossed branding
5. All forged and heat treated parts
6. Safety and reliability with individual serial number
7. Easily disassembled and reassembled
8. Permanent PI code for good traceability

##### Working fields

- \* Shipyards
  - \* Subway sites
  - \* Construction sites
  - \* Metal production workshop
1. Max. load: 1~5 tons Range
  2. Jaw Opening: 0~50mm
  3. Safety factor: 6 times
  4. Safety latch mechanism

##### Subject to rigorous WORK quality approval Inspection Procedures

- \* Vertical lifting of flat plates
- \* Turning over of flat plates
- \* Lifting of shaped steels

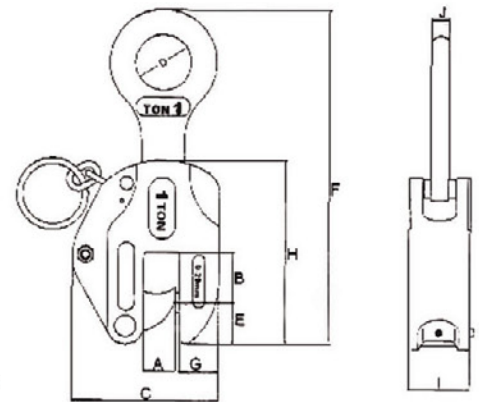

SDC型竖吊钢板起重钳参数:

### SPECIFICATION

型号 Item No.	额定起重量 Wll (t)	钳口宽度 Jaw opening (mm)	主要尺寸 Dimensions(mm)										净重 Net Weight (kg)
			A	B	C	D	E	F	G	H	I	J	
SDC1	1	0~22	24	32	123	46	22	274	29	142	52	12	4.5
SDC2	2	0~32	35	42	152	50	25	302	38	188	63	14	7.0
SDC3	3	0~36	38	48	170	58	35	360	45	203	68	19	11.0
SDC5	5	0~50	52	54	220	62	58	458	58	236	76	20	17.2