

Specification Sheet

Picture:



Product size:

Name: ----- Brown 3 Pendant
Code: ----- 3204
Finish: ----- Polished
Main Material: --- Stainless steel
Shade Material: -- Opal Glass

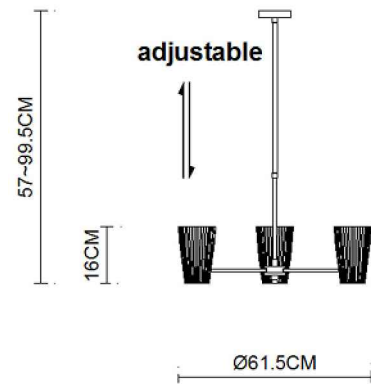

Lamp Source: E14

Wattage: 3x40W / 3x9W

Input Voltage: 220~240 V

Lumen: 1020 lm

Switch: Na

Energy Efficiency Class:

Plug: Na

Specification:



Inner Box:

Gross Weight: 15.4KGS

565*495*175(mm) 1pc

Net Weight: 8.8KGS

Outer Carton:

585*515*730(mm) 4pcs

Cable Length / Terminal Block:

Installation Instruction:

