

Specification Sheet

Picture:



Product size:

Name: ----- Raster 2 Bar pendant

Code: ----- 3517

Finish: ----- Polished

Main Material: --- Stainless steel
+ Steel

Shade Material: -- Fabric+PVC

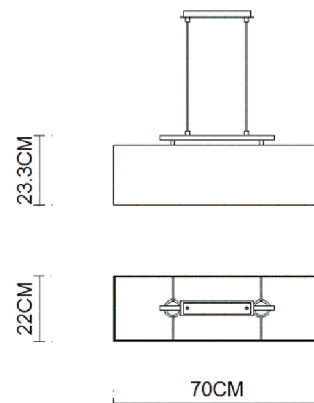

Lamp Source: E27

Wattage: 2x40W / 2x12W

Input Voltage: 220~240 V

Lumen: 680 lm

Switch: Na

Energy Efficiency Class:

Plug: Na

Specification:



Inner Box:

Gross Weight: 13 KGS

730*250*240(mm) 1pc

Net Weight: 6 KGS

Outer Carton:

745*520*510(mm) 4pcs

Cable Length / Terminal Block:

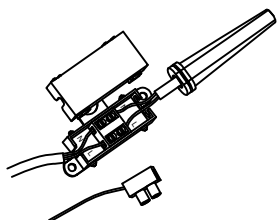

Installation Instruction:

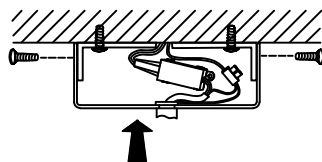

size:230x40xH:20

