

# Specification Sheet

Picture:

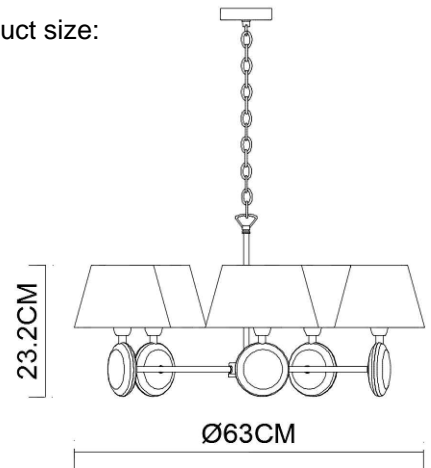

Product size:



Name: ----- Napoleon 5 pendant

Code: ----- 3047

Finish: ----- Polished

Main Material: --- Stainless steel  
+ Steel

Shade Material: -- Fireproof Paper

Lamp Source: E14

Wattage: 5x40W / 5x9W

Input Voltage: 220~240 V

Lumen: 1700 lm

Switch: Na

Energy Efficiency Class:

Plug: Na

Specification:



IP20

Inner Box:

Gross Weight: 15.7KGS

605\*245\*570(mm) 1pc

Net Weight: 8.8KGS

Outer Carton:

620\*590\*1010(mm) 4pcs

Cable Length / Terminal Block:

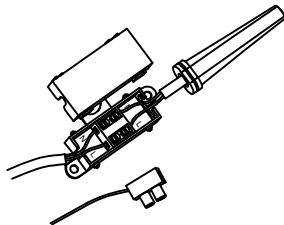

Installation Instruction:

