

Specification Sheet

Picture:



Product size:

Name: ----- Cross 3 Pendant
Code: ----- 3171
Finish: ----- Polished
Main Material: -- Stainless steel
Shade Material: -- Fabric+PVC

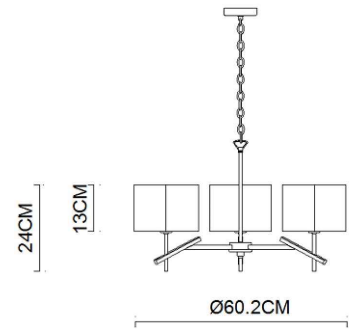

Lamp Source: E14

Wattage: 3x40W / 3x9W

Input Voltage: 220~240 V

Lumen: 1020 lm

Switch: Na

Energy Efficiency Class:

Plug: Na

Specification:



Inner Box:

Gross Weight: 6.7KGS

535*235*485(mm) 1pc

Net Weight: 2.7KGS

Outer Carton:

555*505*500(mm) 2pcs

Cable Length / Terminal Block:

Installation Instruction:

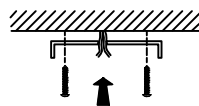
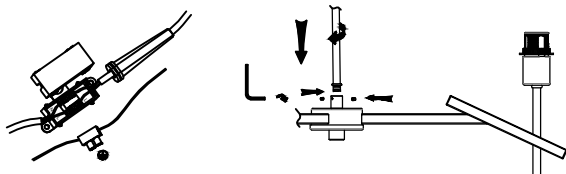

size:90*90*20

