

# Specification Sheet

Picture:



Product size:

Name: ----- Droplet Twin Wall Lamp

Code: ----- 1540

Finish: ----- Polished

Main Material: --- Stainless steel

Shade Material: -- Fireproof Paper

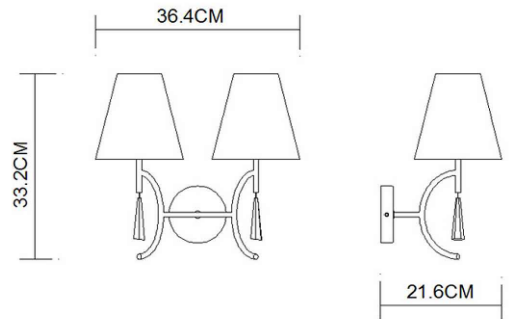

Lamp Source: E14

Wattage: 2x40W / 2x9W

Input Voltage: 220~240 V

Lumen: 680 lm

Switch: Na

Energy Efficiency Class:

Plug: Na

Specification:



Inner Box:

Gross Weight: KGS

260\*250\*270(mm) 1pc

Net Weight: KGS

Outer Carton:

540\*520\*840(mm) 12pcs

Cable Length / Terminal Block:

Installation Instruction:

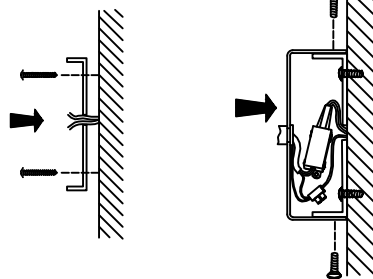
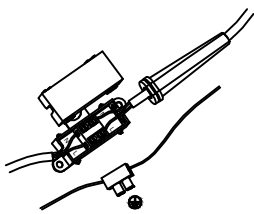

size:Φ102\*22

