

AUTOMATIC HYDRAULIC CLIMBING FORMWORK SYSTEM

自动液压爬升模板系统



COMPANY PROFILE

公司介绍

GETO is mainly engaged in green construction and new energy.

Green construction products include formwork and prefabricated construction, specifically aluminium formwork, climbing systems, steel formwork, steel-framed timber formwork, fair-faced concrete buildings, assembly precast concrete components, PPVC/MIC precast housing molds and prefabricated steel structures.

The main focus of new energy is investment, construction, and operation of "Photovoltaics, Storage, and Charging" projects.

In 2021, GETO was listed on the ChiNext board of the Shenzhen Stock Exchange in China. We have established 12 production bases around the world and registered 32 international trademarks in different countries and regions.

志特集团主营绿色建筑和新能源两大板块。

绿色建筑包括模架及装配式建筑，即铝模，爬升式模架，钢模板体系，钢框木模，清水混凝土特色建筑，装配式建筑 PC、整屋装配式 PPVC/MIC，装配式钢结构。

新能源主营“光、储、充”项目投资、建设、运维。

“志特新材”于 2021 年在 A 股创业板挂牌上市，目前已在全球设立 12 大生产基地，在 32 个国家和地区注册了“GETO®”国际商标，产品和服务遍及全球。



CONTENTS

目录

01

GTP100 AUTOMATIC HYDRAULIC CLIMBING FORMWORK INTRODUCTION GTP100 自动液压爬升模板系统介绍

Profile 简介	4
Application 产品应用	5-6
Features and Advantages 特点和优势	7-8
Components 产品构件组成	9-18
Technical Data 技术参数	19

02

CLIMBING PROCESS PRINCIPLE 爬升工艺原理

Climbing Rail Principle 导轨爬升原理	20
Climbing Bracket Principle 架体爬升原理	21

03

PROJECT CASE 项目案例

Residential Building in Asia 亚洲住宅楼项目	22-23
---	-------

PROFILE 简介



GTP100 Automatic hydraulic climbing formwork system is a construction technique that includes the climbing bracket, formwork, platform system, and suspension bracket, which are attached to the concrete structure. Once the formwork is stripped off from the shaped concrete, it driven by the hydraulic cylinders and guided by the climbing rail, the brackets climb up to the next level, repeating this cycle for the construction process.

The formwork is integrated with the climbing brackets, moving forward and back together with the travelling units, thus significantly reducing labor costs. The enclosed construction environment effectively prevents falls from heights.

Suitable for large structures such as internal shafts, facade walls, core, shear walls, massive columns, bridge towers, signal towers, and silos.

GTP100 自动液压爬升模板系统是一种包括爬升架、模板、操作平台及吊架等，附着在混凝土结构上，当新浇筑的混凝土脱模后，以液压油缸为动力，以导轨为爬升轨道，将爬模架体向上爬升一层，反复循环作业的施工工艺。

竖向墙体模板随爬升架体整体爬升，整体合模和退模，大大降低人工成本；封闭的施工环境，有效避免高空坠物。

适用于建筑内井筒、建筑外墙、核心筒、剪力墙、巨型柱、桥塔、信号塔和筒仓等大型构筑物。

APPLICATION 产品应用

OPERATING CONDITIONS 使用条件

Conditions for climbing formwork construction and climbing 爬模允许施工、爬升的条件

- No severe weather conditions (e.g., thunderstorms, rain, snow, fog, frost, haze, or hail) during operation.
运行时无雷、雨、雪、雾、霜、霾、冰雹等恶劣气象条件。
- Basic wind pressure does not exceed level 5 (approximately 24.5-28.5 m/s).
基本风压不大于 5 级风 (约 24.5-28.5 米 / 秒)。

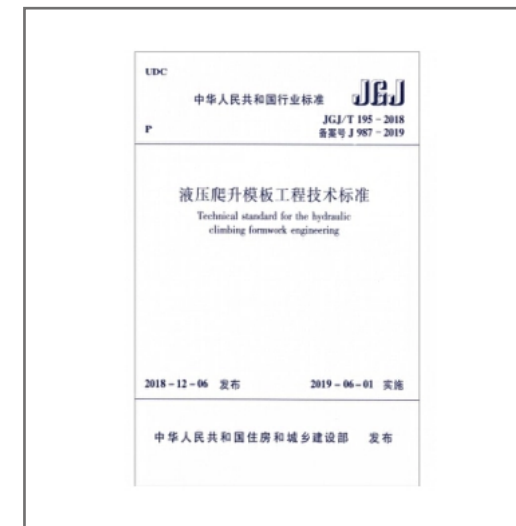

In wind speeds over level 7 (approximately 13.9-17.1 m/s), typhoon reinforcement measures are required for the climbing formwork bracket.

在风速超过 7 级风 (约 13.9-17.1 米 / 秒) 的情况下，爬模架体须做防台风加固措施。

Note: Referring to the technical standards outlined in the "Technical Standard for the Hydraulic Climbing Formwork Engineering" of the People's Republic of China.

注意：参照中华人民共和国《液压爬升模板工程技术标准》文件标准。

APPLICATION 产品应用

APPLICATION SCOPE 应用场景

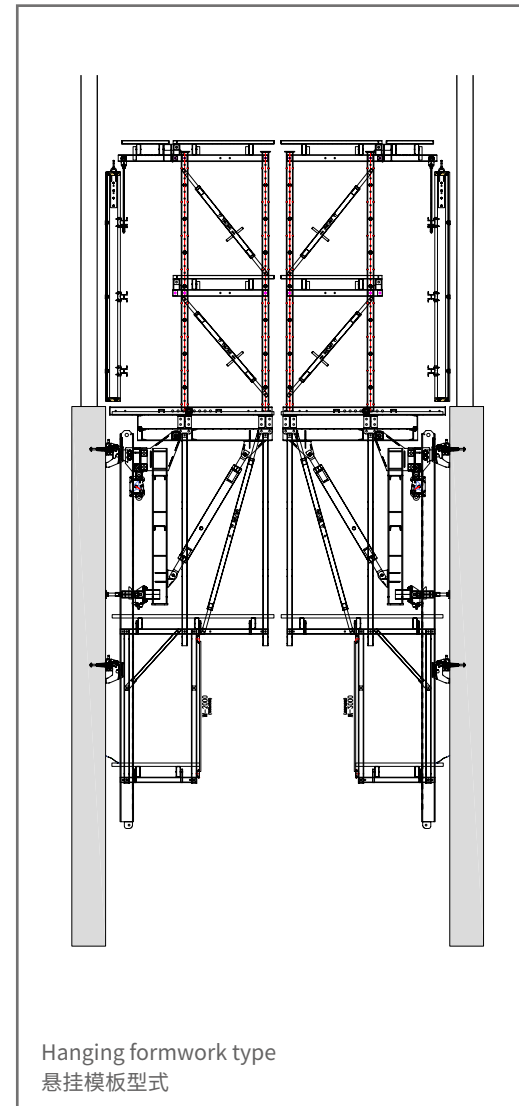
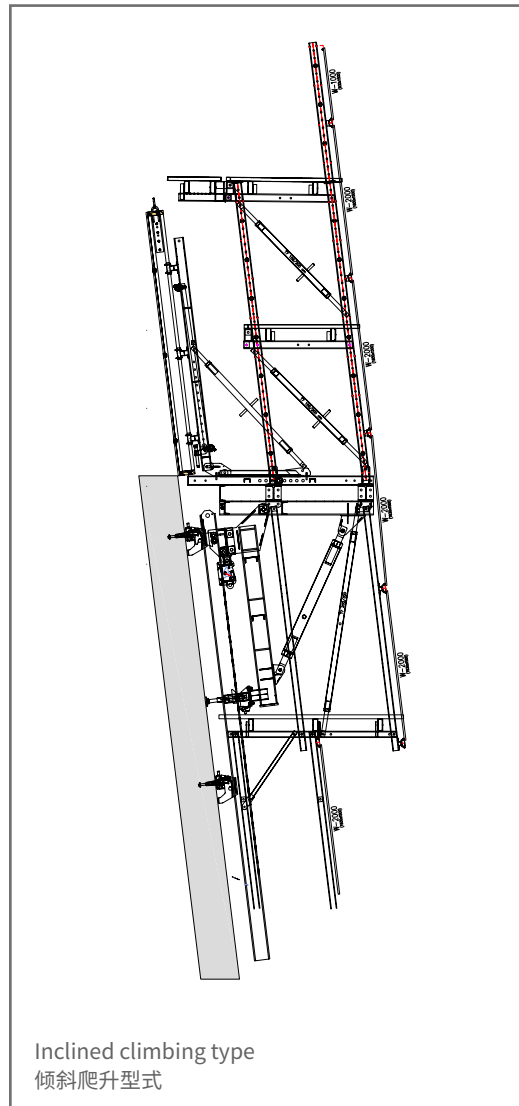

FEATURES AND ADVANTAGES 特点和优势

SAFETY 安全性

- Fully steel-hardened design improves the structural stability, reliability, and fire resistance of climbing bracket.
爬模采用全钢化设计，提高了架体自身稳定性、可靠性、防火性。
- Formwork retraction gear reduces construction risks and effectively prevents grout leakage from the formwork traveling device.
爬模采用齿轮齿条后退模板的退模形式，降低施工危险性，有效防止退模装置漏浆。
- Climbing bracket utilizes fully enclosed steel protective screening.
架体采用全封闭钢防护网结构。
- Vertical and inclined hydraulic climbing options ensure a smooth, synchronous, and safe.
可竖直爬升、斜爬，液压爬升过程平稳、同步、安全。
- Rebar installation platform is synchronized with climbing, ensuring safe operations.
钢筋绑扎随升随绑，操作安全。

HIGHLY COST-EFFICIENT 经济适用性

- Providing all-round operational platforms saves materials and labor.
提供全方位的操作平台，节省材料和劳动力。
- After low-level assembly, the climbing bracket continuously climbs to the top, reducing formwork damage.
爬模架体在低处一次组装后，一直运行使用爬升到顶，减少模板损毁。

FEATURES AND ADVANTAGES 特点和优势

CONVENIENCE 便利性

- Modularizing the protective screening for easy installation and transportation.
将防护网模块化，方便安装及运输。
- Each platform are fully steel-hardened, modular pedals for convenient transportation and easy installation.
各平台踏板采用全钢化、模块化踏板，运输方便，安装简便。
- The climbing formwork self-climbing with formworks, enabling direct adjustments and cleaning on the climbing bracket, without requiring crane lifting, scaffolding, or level-by-level alignment.
爬模携带模板自爬升，在架体上清理调整模板，不需塔吊吊装模板或架体，也不需要层层放线和搭设脚手架。
- The bracket can be climbed both integratedly or separately.
爬升架体可整体爬升，也可分片爬升。

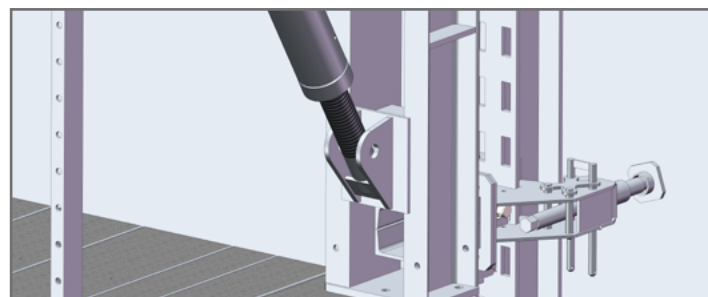
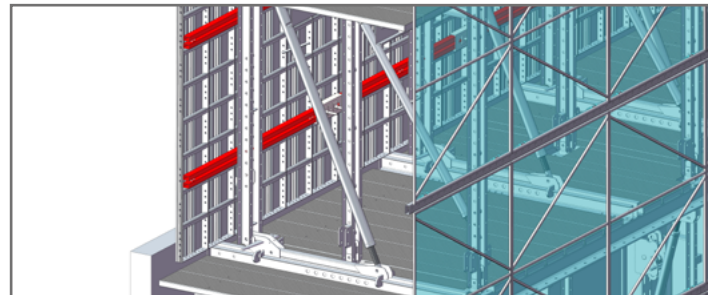
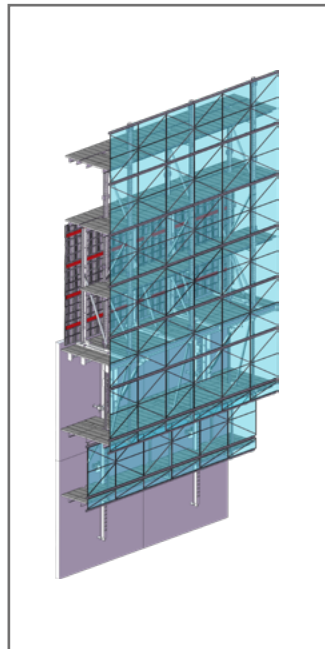

COMPONENTS 产品构件组成



- A** Climbing system: climbing rail, hydraulic cylinder, lifting mechanism, climbing head, vertical profile, main horizontal profile, diagonal bracing spindle strut, supporting carriage.
爬升系统：导轨、液压油缸、提升装置、爬升挂头、竖杆、主水平杆、斜撑轴杆、顶墙支座
- B** Main platform beam: H200 beam, 20# U channel beam.
主平台梁：H200 梁、20# 槽钢梁
- C** Lower platform hanging bracket: -1F vertical suspension profile, -1F horizontal profile, diagonal bracing, -2F vertical suspension profile, -2F horizontal profile.
下平台挂架：-1 层竖吊杆、-1 层水平杆、斜撑杆、-2 层竖吊杆、-2 层水平杆
- D** Formwork traveling unit: vertical waler, horizontal profile, diagonal bracing spindle strut.
退模组件：竖背楞、水平杆、斜撑轴杆
- E** Anchoring system: attachment support, embeded climbing cone, M36 screw, stop anchor, sealing sleeve.
锚固系统：附着支座、预埋爬锥、M36 螺栓、止动埋件、密封胶套
- F** Upper platform bracket: upper platform vertical profile, upper platform horizontal profile, diagonal bracing, flip platform horizontal profile.
上平台支架：上平台竖杆、上平台水平杆，斜撑杆、翻转平台横杆

COMPONENTS 产品构件组成

CLIMBING SYSTEM 爬升系统

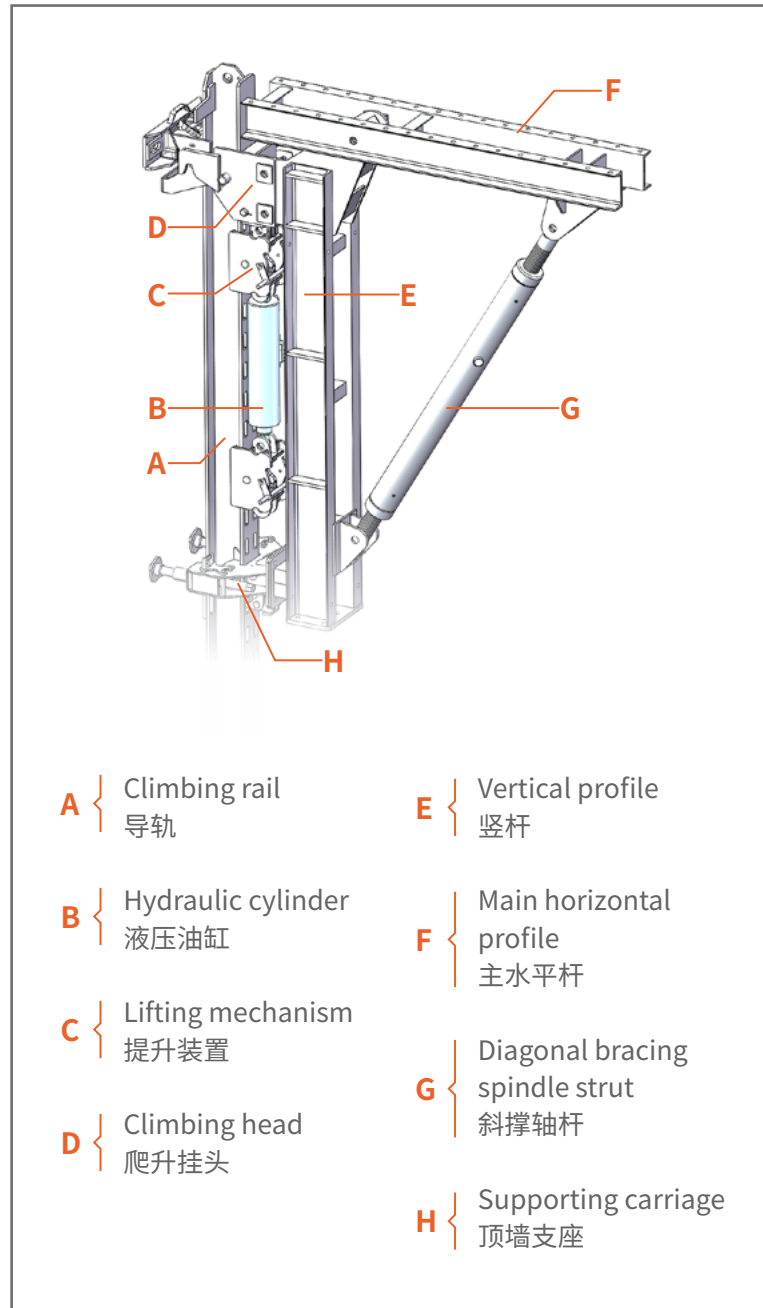

COMPONENTS 产品构件组成

TECHNICAL DATA OF CLIMBING SYSTEM 爬升系统技术参数

S/N 序号	Item 项目	Specification 设计值	Remark 备注
1	Climbing Distance per Stroke 每个行程爬升距离	150mm	
2	Hydraulic Cylinder Stroke 油缸行程	250mm	
3	Maximum Climbing Height 最大爬升高度	5.5m	Add support in the middle of the climbing rail, otherwise it is 4.5m. 导轨中间加支撑, 不加为 4.5m。
4	Maximum Lifting Capacity 最大提升能力	100kN	

COMPONENTS 产品构件组成

MAIN PLATFORM BEAM 主平台梁

- Primary load-bearing components: H200 beam & 20# U channel beam.
主要受力构件由 H200 梁和 20# 槽钢梁构成。
- H200 beam supports upper and lower platform loads, while the 20# U channel beam supports formwork weight.
H200 梁承受上平台和下平台全部荷载，20# 槽钢梁承受模板自重。
- Modular design with 120mm hole spacing on the upper surface utilizing end flange connections for equal strength.
模数化设计，上表面孔距 120mm 采用端头法兰连接，等强设计。

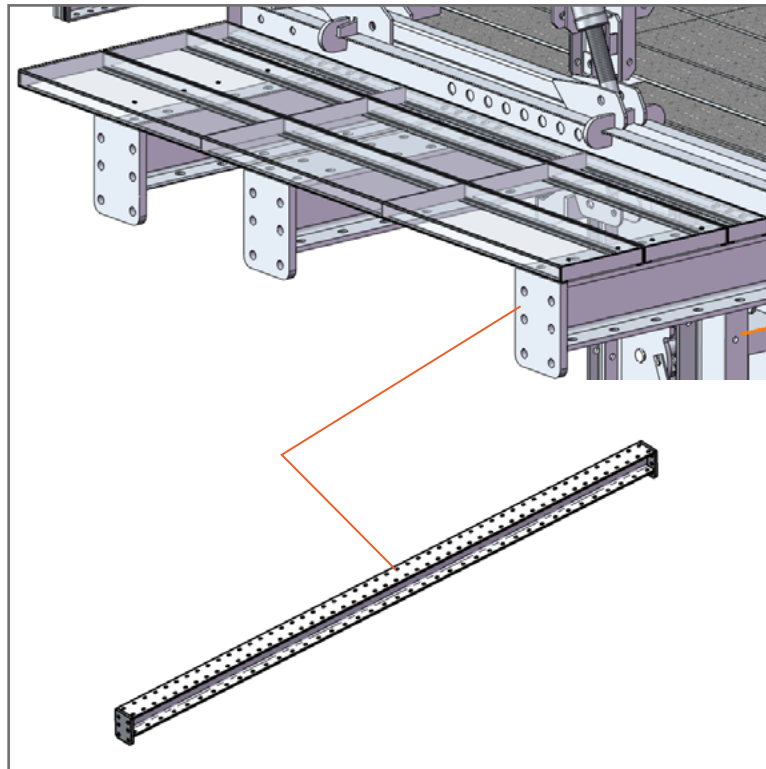

COMPONENTS 产品构件组成

LOWER PLATFORM HANGING BRACKET 下平台挂架

- Main materials: 8# U channel for vertical profile (single piece) and horizontal profile (double-pinned).
主要材料均为 8# 槽钢，竖吊杆为单根，水平杆为双拼。
- The platform width is 2.4 meters on -1F and 1.3 meters on -2F.
-1 层平台宽度 2.4m，-2 层平台宽度 1.3m。
- Replace diagonal bracing on -2F with diagonal bracing spindle strut to keep the platform horizontal when the climbing bracket tilts.
-2 层斜撑杆可换成斜撑轴杆，在架体倾斜时保证平台始终处于水平状态。

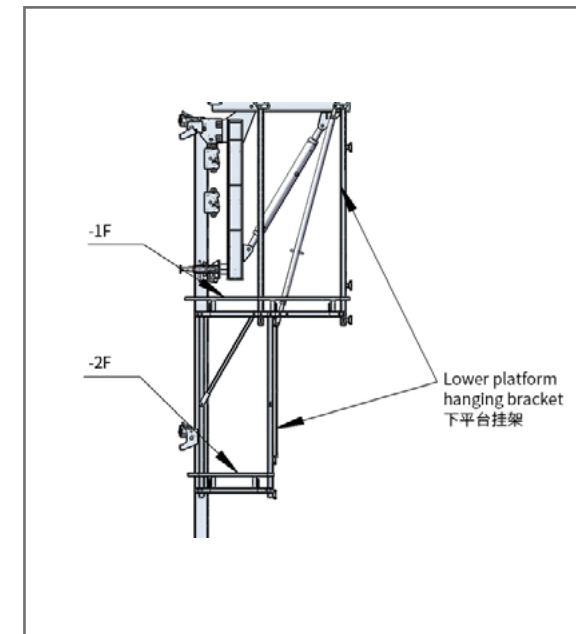

COMPONENTS 产品构件组成

UPPER PLATFORM BRACKET 上平台支架

- Main materials: 10# U channel for vertical profiles (double piece) and horizontal profile (single piece).
主要材料均为 10# 槽钢，竖杆为双根，水平杆为单根。
- The platform width on levels +1F & +2F: 1.4 meters.
+1 层、+2 层平台宽度为 1.4m。
- Diagonal bracing spindle strut: 2m~2.5m.
斜撑轴杆 2m~2.5m 通用。
- The flipping platform enables direct lifting of formwork for replacement, facilitating construction and rebar binding.
翻转平台的作用为在模板需要更换时，模板可直接被吊出，便于施工和绑扎钢筋。

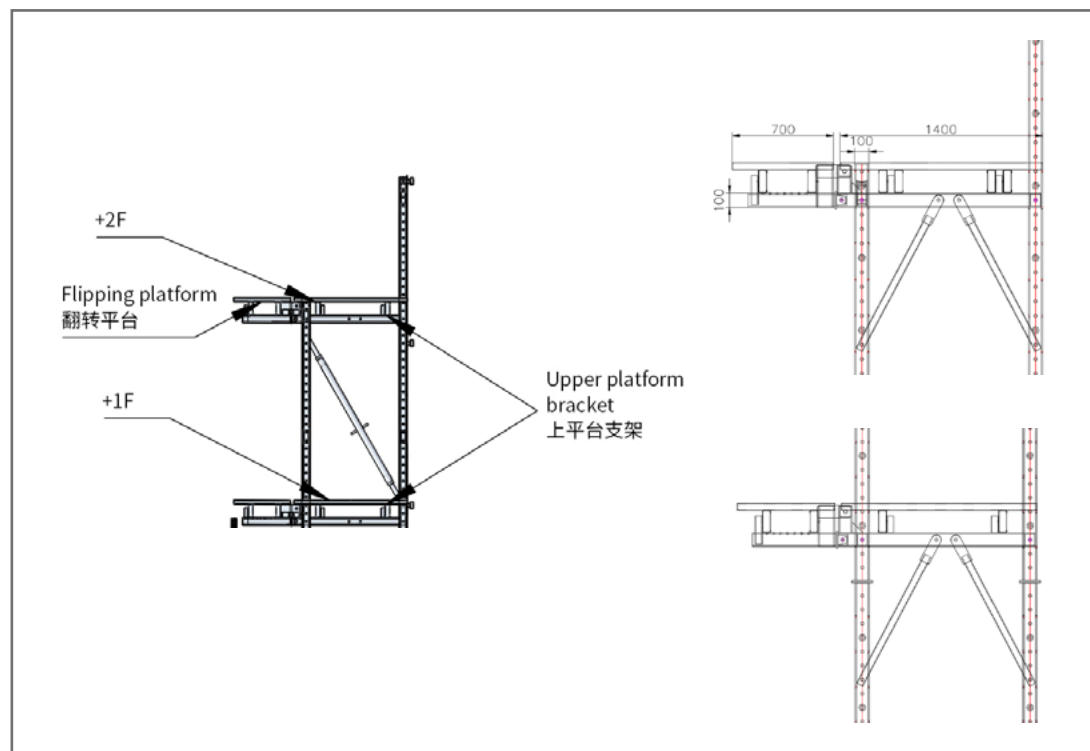

COMPONENTS 产品构件组成

PLATFORM BEAM, PLATFORM BOARD 平台梁、平台板

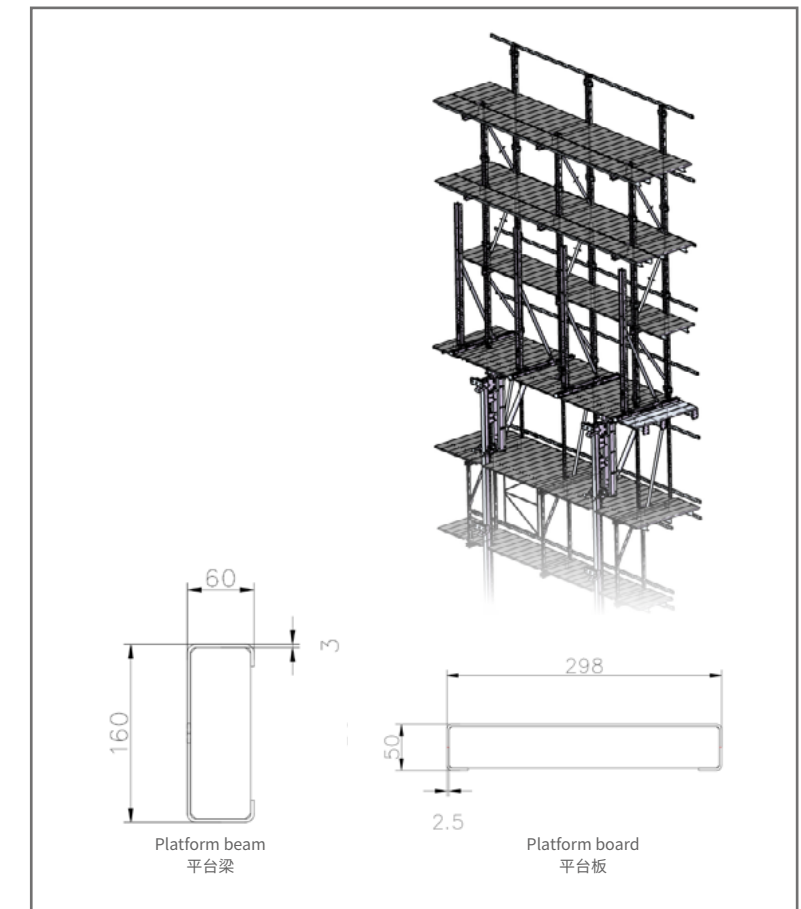

- The platform beams: C160x60x3, with modular lengths customizable to design requirements.
平台梁均为 C160x60x3，长度根据设计确定，可模数化。
- Standard platform boards: 300mm wide, 2mm thick. Non-standard widths: 150mm-400mm, 2mm thick.
平台板标准宽度为 300mm，非标为 150mm-400mm，厚度 2mm。
- Platform boards are affixed to beams using self-tapping screws.
平台板与平台梁使用自攻钉连接。

COMPONENTS 产品构件组成

FORMWORK TRAVELING UNITS 退模组件

- The formwork traveling horizontal profile is made of 12# U channel, with detachable gears.
退模水平杆主要材料为 12# 槽钢，中间装有可拆卸齿轮。
- The vertical waler, made of double 12# U channel, supports formwork weight with height adjustment parts.
竖背楞为双 12# 槽钢组成，带有模板高度调节件，承受模板自重。
- Compatible with aluminium formwork, timber-beam formwork, and steel formwork, requiring replacement of hook screws and height adjustment spindles for the waler.
可搭配铝模、木梁模板、钢模，针对背楞需更换钩头螺栓和模板高度调节件。
- Horizontal wedge irons snug formwork against walls, while vertical wedge irons secure formwork traveling components.
水平楔铁打紧可让模板紧贴墙面，竖向楔铁打紧可卡紧退模组件。

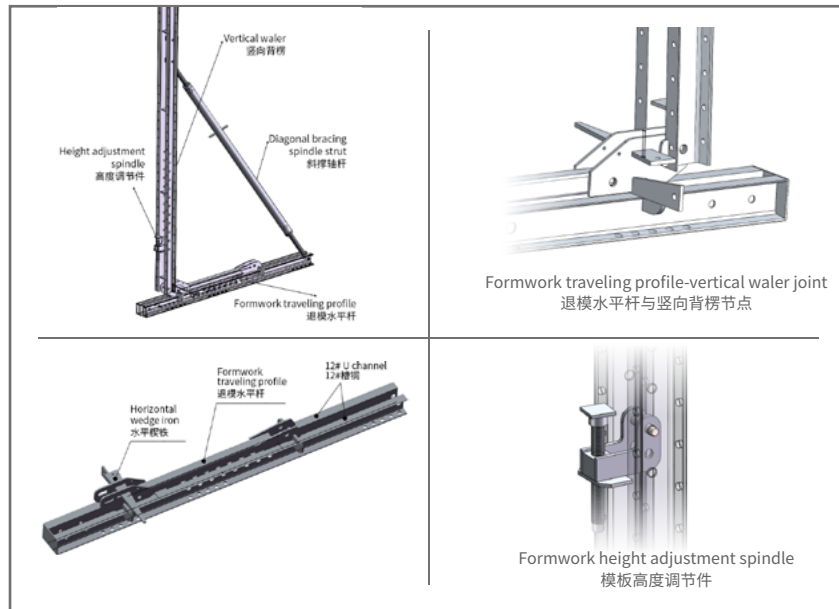

COMPONENTS 产品构件组成

ANCHORING SYSTEM 锚固系统

Suspending the climbing bracket head with a pin transfers the load to the structure. An upper irregular hole with a safety pin prevents accidental climbing bracket raising.
通过插销悬挂爬升挂头，将荷载传递到结构上，上部异形孔插入安全插销，防止误操作造成架体上升。



COMPONENTS 产品构件组成

EXTERIOR PROTECTIVE SCREENING 外防护网

- Exterior protective material utilizes the climbing platform series' exterior protective screening, with horizontal profile as pole, spaced up to 2m apart vertically.
外防护材料沿用爬架系列的外防护网框，横杆为爬架立杆，横杆竖向最大间距 2m。
- Toe boards required on each platform.
各层平台外侧需配置挡脚板。

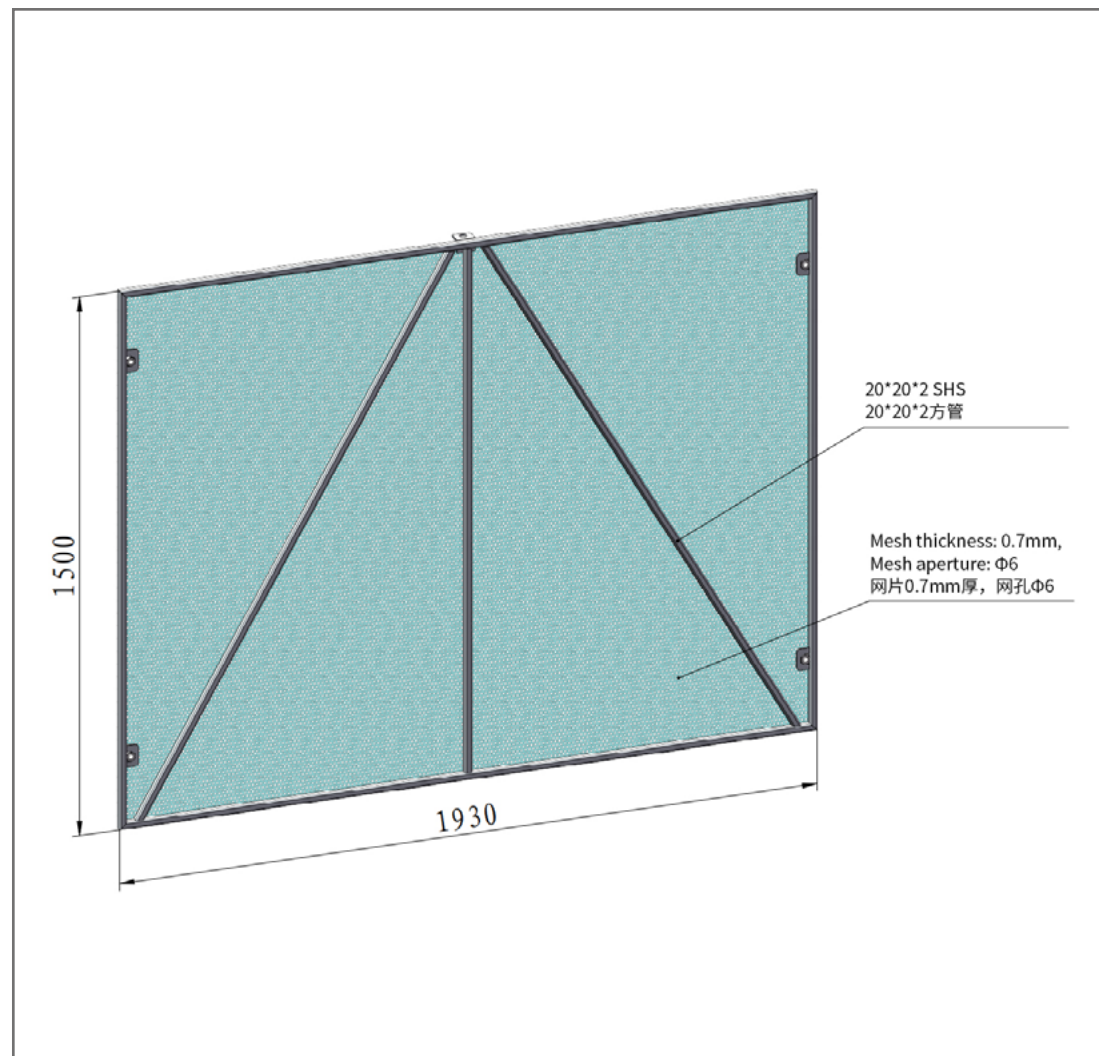

TECHNICAL DATA 技术参数

TECHNICAL DATA OF GTP100 AUTOMATIC HYDRAULIC CLIMBING FORMWORK SYSTEM GTP100 自动液压爬升模板系统技术参数

S/N 序号	Item 项目	Specification 设计值
1	Lifting Capacity (single-unit climbing platform) 提升能力 (单樰爬架)	100kN
2	Segmented Standard Pouring Height 节段标准浇筑高度	3.0m – 5.5m
3	Maximum Climbing Height 最大爬升高度	5 min/m
4	Influence Width per Bracket 每个爬架作业范围	About 4m (subject to project specifics) 约 4m (根据项目具体情况而定)
5	Working Platform Width 爬架作业宽度	2.4m
6	Max Inclination 倾斜角度	+/- 10°
7	Driving Force 驱动力	Hydraulic power 液压动力
8	Wall Formwork System 配套墙体模板系统	Aluminium formwork / Steel formwork / Timber- beam formwork 铝模板 / 钢模板 / 木梁模板

CLIMBING RAIL PRINCIPLE 导轨爬升原理

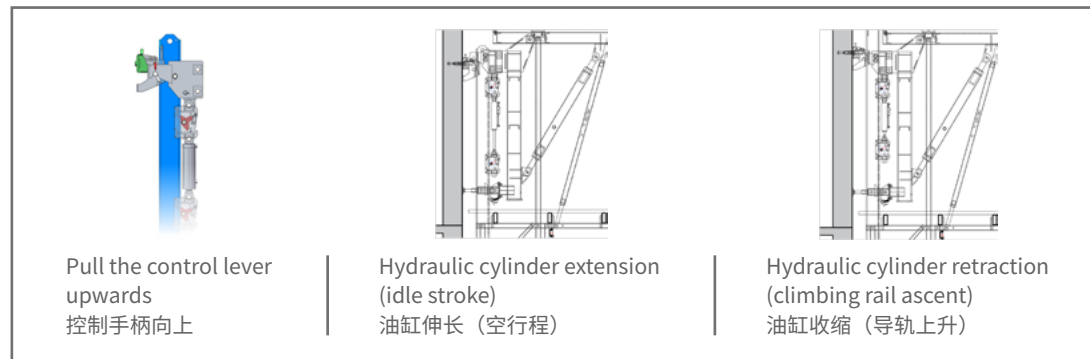

KEY POINTS 要点

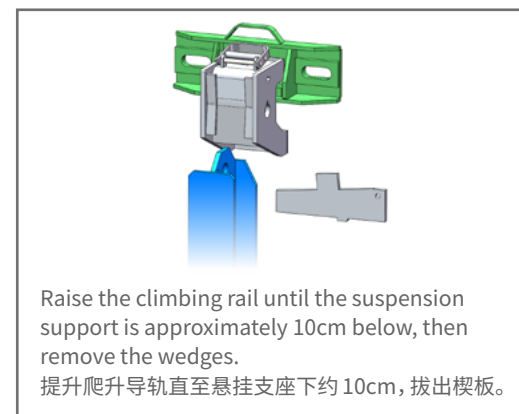
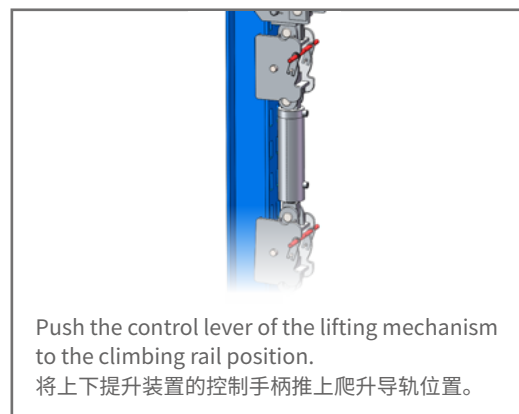

CLIMBING BRACKET PRINCIPLE 架体爬升原理

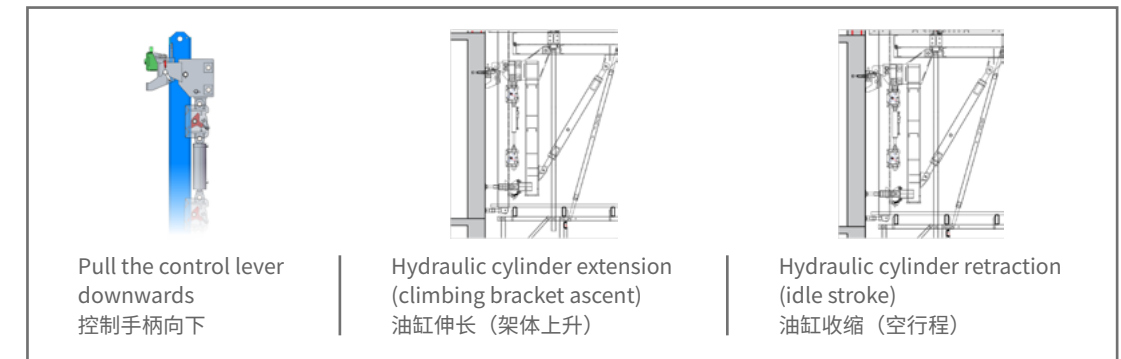

KEY POINTS 要点

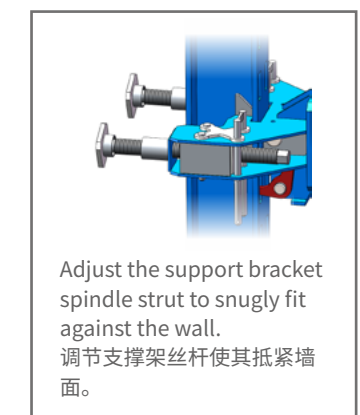
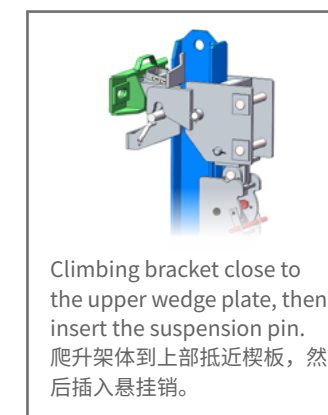

PROJECT CASE 项目案例

RESIDENTIAL BUILDING IN ASIA 亚洲住宅楼项目

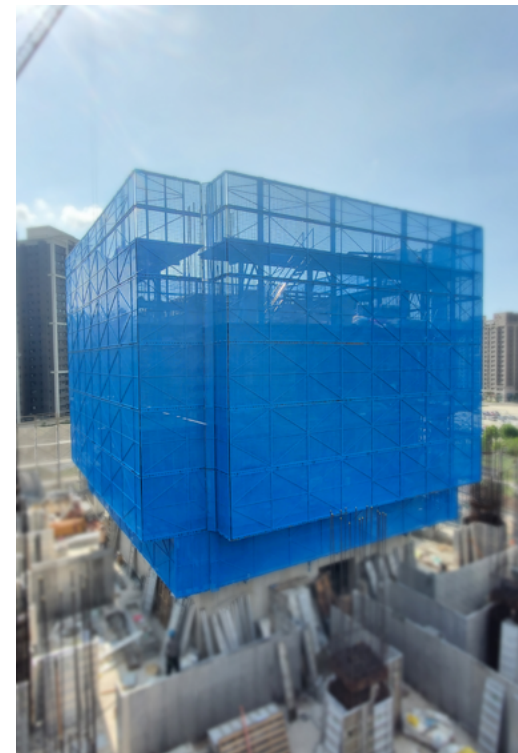
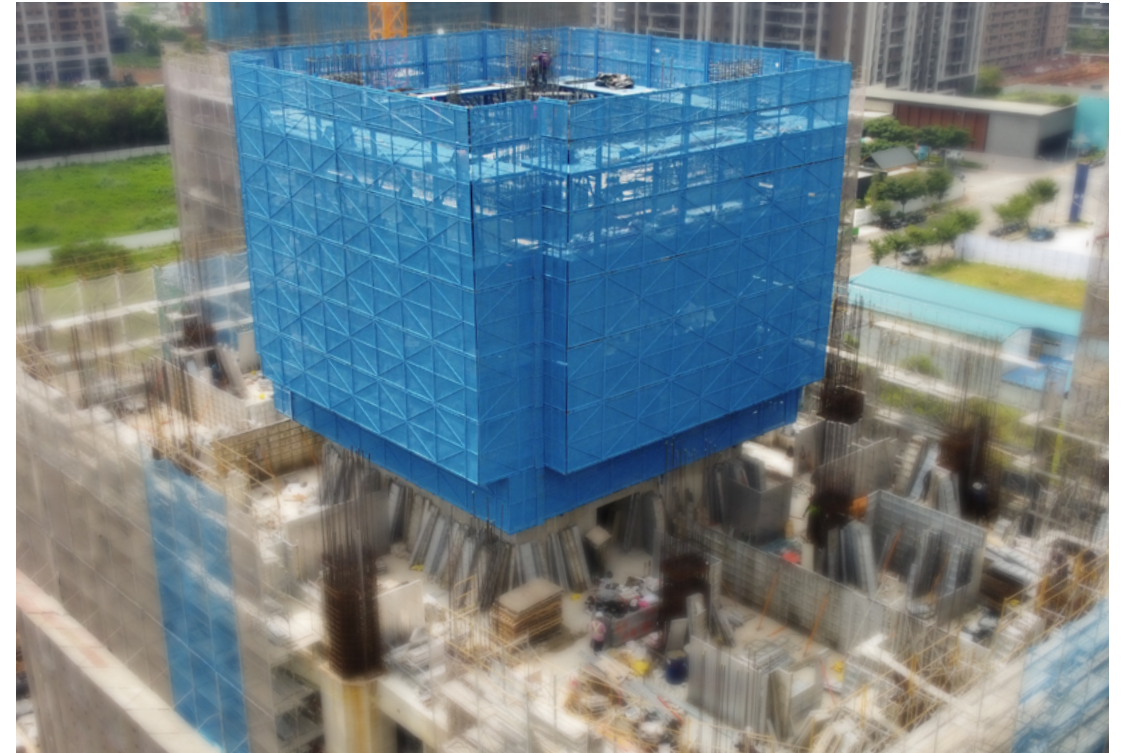

GETO Group

Headquarters:

Greater Bay Area—No. 13 Heqing Road, Tsuihang New District, Zhongshan City, Guangdong Province

Southern China Production Base I :

Cuishan Lake Science and Technology Park, Kaiping, Jiangmen City ,Guangdong Province

Southern China Production Base II :

Huizhou Industrial Transfer Industrial Park, Huizhou City, Guangdong Province

Eastern China Production Base I :

Guangchang Industrial Park, Fuzhou City, Jiangxi Province

Central China Production Base:

Hi-tech Industry Development Zone, Xianning City, Hubei Province

Northern China Production Base:

China Aluminium Industrial Park, Linqu, Weifang City, Shandong Province

Southwest China Production Base:

Modern Manufacturing Industrial Park, Tongnan High-Tech District, Chongqing City

Northwest China Production Base:

The Circular Economy Park, Anding District, Dingxi City, Gansu Province

Hainan Production Base:

Gold Medal Port Industrial Park, Lingao County, Hainan Province

ASEAN Production Base:

Negeri Sembilan, Malaysia

Singapore Production Base :

West Region, Singapore

Saudi Arabia Production Base :

Riyadh, Saudi Arabia

Contact

Sales Hotline: 0086-760-88589004

E-mail: geto_market@geto.com.cn

Website: www.getoformwork.com

20241127V1

